

TRANSFORMER
S17/J17 PINOUT

1	EA	EA	EA	EA	EA	EA	EA	EA	EA
2	EA	EA	EA	EA	EA	EA	EA	EA	EA
3	EA	EA	EA	EA	EA	EA	EA	EA	EA
4	EA	EA	EA	EA	EA	EA	EA	EA	EA
5	EA	EA	EA	EA	EA	EA	EA	EA	EA
6	EA	EA	EA	EA	EA	EA	EA	EA	EA
7	EA	EA	EA	EA	EA	EA	EA	EA	EA
8	EA	EA	EA	EA	EA	EA	EA	EA	EA
9	EA	EA	EA	EA	EA	EA	EA	EA	EA
10	EA	EA	EA	EA	EA	EA	EA	EA	EA
11	EA	EA	EA	EA	EA	EA	EA	EA	EA
12	EA	EA	EA	EA	EA	EA	EA	EA	EA
13	EA	EA	EA	EA	EA	EA	EA	EA	EA
14	EA	EA	EA	EA	EA	EA	EA	EA	EA
15	EA	EA	EA	EA	EA	EA	EA	EA	EA

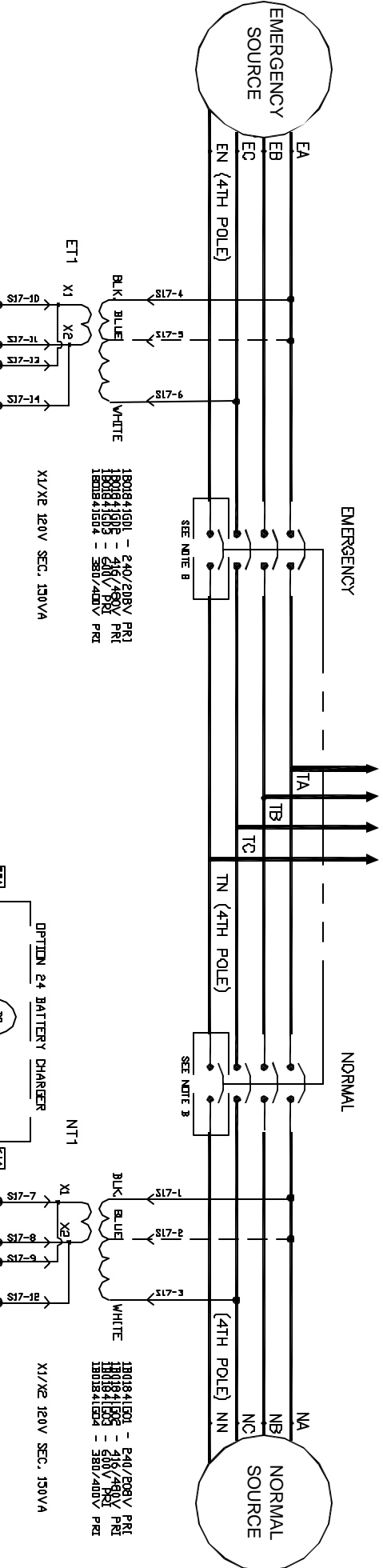

EMERGENCY
S16/J16 PINOUT

1	EA	EA	EA	EA	EA	EA	EA	EA	EA
2	EA	EA	EA	EA	EA	EA	EA	EA	EA
3	EA	EA	EA	EA	EA	EA	EA	EA	EA
4	EA	EA	EA	EA	EA	EA	EA	EA	EA
5	EA	EA	EA	EA	EA	EA	EA	EA	EA
6	EA	EA	EA	EA	EA	EA	EA	EA	EA
7	EA	EA	EA	EA	EA	EA	EA	EA	EA
8	EA	EA	EA	EA	EA	EA	EA	EA	EA
9	EA	EA	EA	EA	EA	EA	EA	EA	EA
10	EA	EA	EA	EA	EA	EA	EA	EA	EA
11	EA	EA	EA	EA	EA	EA	EA	EA	EA
12	EA	EA	EA	EA	EA	EA	EA	EA	EA
13	EA	EA	EA	EA	EA	EA	EA	EA	EA
14	EA	EA	EA	EA	EA	EA	EA	EA	EA
15	EA	EA	EA	EA	EA	EA	EA	EA	EA
16	EA	EA	EA	EA	EA	EA	EA	EA	EA
17	EA	EA	EA	EA	EA	EA	EA	EA	EA
18	EA	EA	EA	EA	EA	EA	EA	EA	EA
19	EA	EA	EA	EA	EA	EA	EA	EA	EA
20	EA	EA	EA	EA	EA	EA	EA	EA	EA
21	EA	EA	EA	EA	EA	EA	EA	EA	EA
22	EA	EA	EA	EA	EA	EA	EA	EA	EA
23	EA	EA	EA	EA	EA	EA	EA	EA	EA
24	EA	EA	EA	EA	EA	EA	EA	EA	EA
25	EA	EA	EA	EA	EA	EA	EA	EA	EA
26	EA	EA	EA	EA	EA	EA	EA	EA	EA
27	EA	EA	EA	EA	EA	EA	EA	EA	EA
28	EA	EA	EA	EA	EA	EA	EA	EA	EA
29	EA	EA	EA	EA	EA	EA	EA	EA	EA
30	EA	EA	EA	EA	EA	EA	EA	EA	EA
31	EA	EA	EA	EA	EA	EA	EA	EA	EA
32	EA	EA	EA	EA	EA	EA	EA	EA	EA
33	EA	EA	EA	EA	EA	EA	EA	EA	EA
34	EA	EA	EA	EA	EA	EA	EA	EA	EA
35	EA	EA	EA	EA	EA	EA	EA	EA	EA
36	EA	EA	EA	EA	EA	EA	EA	EA	EA
37	EA	EA	EA	EA	EA	EA	EA	EA	EA
38	EA	EA	EA	EA	EA	EA	EA	EA	EA
39	EA	EA	EA	EA	EA	EA	EA	EA	EA
40	EA	EA	EA	EA	EA	EA	EA	EA	EA
41	EA	EA	EA	EA	EA	EA	EA	EA	EA
42	EA	EA	EA	EA	EA	EA	EA	EA	EA
43	EA	EA	EA	EA	EA	EA	EA	EA	EA
44	EA	EA	EA	EA	EA	EA	EA	EA	EA
45	EA	EA	EA	EA	EA	EA	EA	EA	EA
46	EA	EA	EA	EA	EA	EA	EA	EA	EA
47	EA	EA	EA	EA	EA	EA	EA	EA	EA
48	EA	EA	EA	EA	EA	EA	EA	EA	EA
49	EA	EA	EA	EA	EA	EA	EA	EA	EA
50	EA	EA	EA	EA	EA	EA	EA	EA	EA
51	EA	EA	EA	EA	EA	EA	EA	EA	EA
52	EA	EA	EA	EA	EA	EA	EA	EA	EA
53	EA	EA	EA	EA	EA	EA	EA	EA	EA
54	EA	EA	EA	EA	EA	EA	EA	EA	EA
55	EA	EA	EA	EA	EA	EA	EA	EA	EA
56	EA	EA	EA	EA	EA	EA	EA	EA	EA
57	EA	EA	EA	EA	EA	EA	EA	EA	EA
58	EA	EA	EA	EA	EA	EA	EA	EA	EA
59	EA	EA	EA	EA	EA	EA	EA	EA	EA
60	EA	EA	EA	EA	EA	EA	EA	EA	EA
61	EA	EA	EA	EA	EA	EA	EA	EA	EA
62	EA	EA	EA	EA	EA	EA	EA	EA	EA

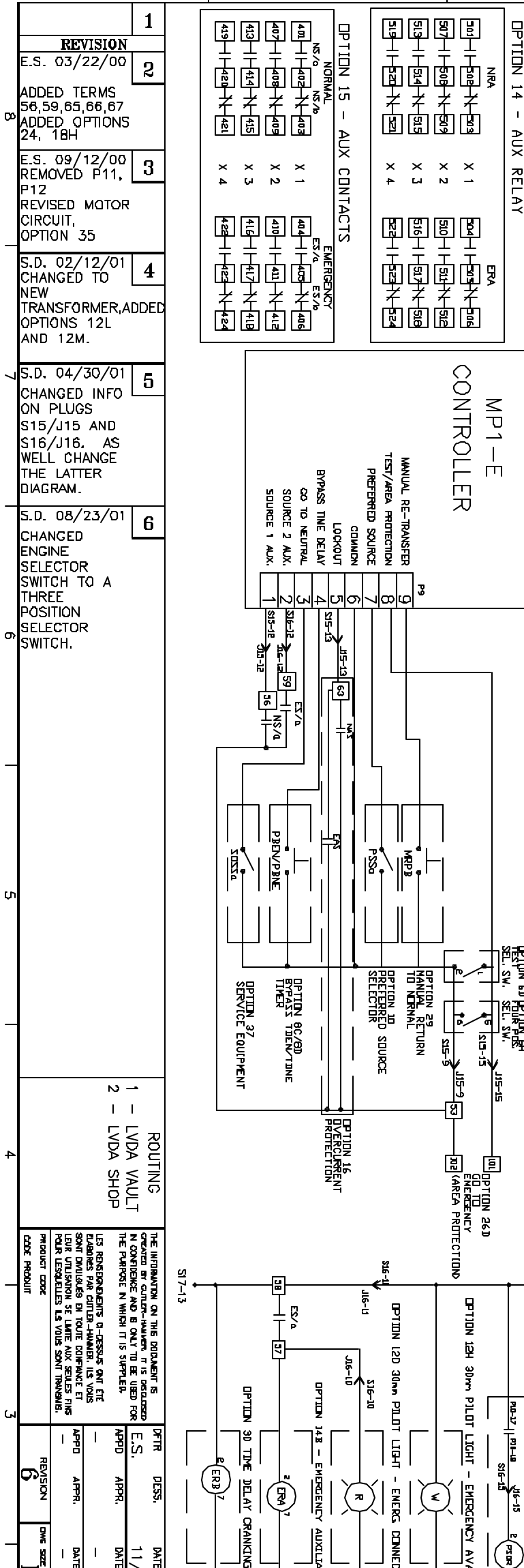
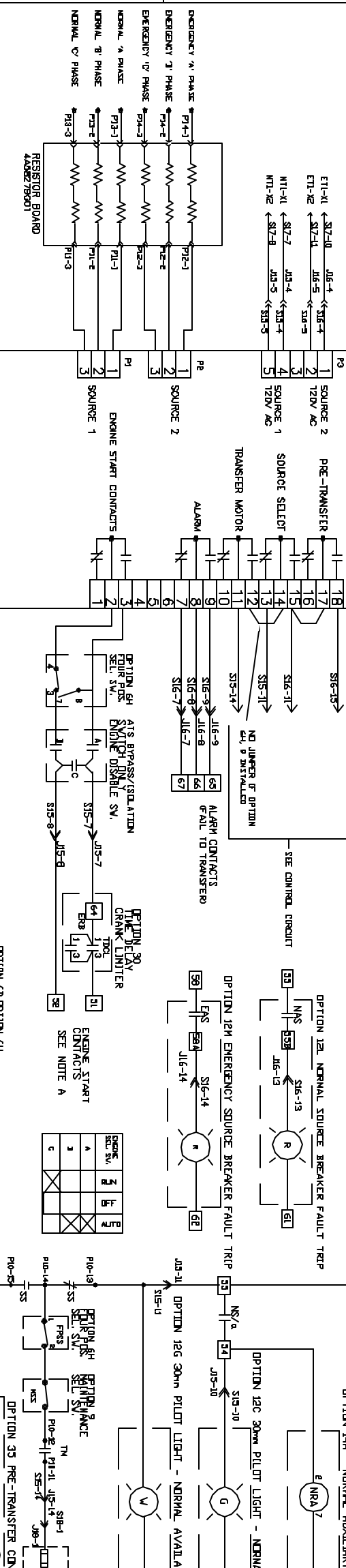

1 - LVDA VAULT
2 - LVDA SHOP

ROUTING

1 - LVDA VAULT
2 - LVDA SHOP

THE INFORMATION ON THIS DRAWING IS...
LES RECOMMANDATIONS...
DANS LES RECOMMANDATIONS...
LES RECOMMANDATIONS...
DANS LES RECOMMANDATIONS...

DATE: 11/22/99
DESIGNER: [Signature]
CHECKER: [Signature]
DATE: [Signature]
DATE: [Signature]

Cutler-Hammer LVDA OAKVILLE, ON
AUTOMATIC TRANSFER SWITCH WIRING DIAGRAM
1B03395 1 OF 1

LEGEND & NOTES

COMMON REFERENCE

FEMALE CONNECTION

FIXED MOUNT SWITCHING DEVICE

INDICATOR LIGHT

MALE CONNECTION

MECHANICAL INTERLOCK

N.C. PUSHBUTTON

N.C. SELECTOR SWITCH

N.C. CONTACT

N.O. CONTACT

N.O. PUSHBUTTON

N.O. SELECTOR SWITCH

RELAY DR TIMER, 120VAC

TERMINAL BLOCK

BC - BATTERY CHARGER

EAS - EMERGENCY BREAKER BELL ALARM

EBA - EMERGENCY AUXILIARY RELAY

ERB - EMERGENCY SOURCE AUXILIARY RELAY

ESX - EMERGENCY AUXILIARY SWITCH

EX - EMERGENCY CUSTOMER CONNECTION

ETM - ELAPSED TIME METER

MSP-B - MANUAL RETURN PUSHBUTTON

MSS - MAINTENANCE SELECTOR SWITCH

NAS - NORMAL BREAKER AUXILIARY RELAY

NRA - NORMAL AUXILIARY RELAY

NSX - NORMAL AUXILIARY SWITCH

NX - NORMAL CUSTOMER CONNECTION

JX - FEMALE CONNECTOR

PX - BOARD EDGE CONNECTOR

SX - SELECTOR SWITCH

SX - MALE CONNECTOR

TJCL - TIME DELAY CRANK LIMITER

Tx - LOAD CUSTOMER CONNECTION

NOTE A) TERMINALS ARE TO BE CONNECTED TO REMOTE START CONTACT FROM GENERATOR

NOTE B) NEUTRAL SWITCHED ON 4 POLE DEVICE

ATS SHOWN WITH SWITCH DE-ENERGIZED, IN NEUTRAL POSITION

FOR LIST OF OPTIONS INSTALLED ON PARTICULAR SWITCH, SEE CUSTOMER INFORMATION DRAWING.

FOR FURTHER DESCRIPTION OF OPERATION SEE IL153011.K/J

OPTION 35 - PRE-TRANSFER

(a) PSDR-FORM C

(b) PSDR-ISOLATED

OPTION 64

4 PDS. SELECTOR SWITCH - LOGIC

CONTACT	TEST	AUTO	MAN	ENG.
1-1-2	X	X	X	X
3-1-4	X	X	X	X
5-1-6	X	X	X	X
7-1-8	X	X	X	X