



Closed Transition Soft Load Transfer Switches

Index	Page
General Description	2
Applications	2
Sequence of Operations	2
Technical Specifications	4
Buswork	6
SPB Circuit Breakers	6
Generator Power Controller	7
Display/Programmer	7
Optional Components	9
Communications	11
Optional Features	12
Setpoints and Adjustments	12
Dimensions	18
Catalog Number Selection Guide	19
Appendices	20



General Description

Electrical power generation located at or near the point of it's consumption, commonly referred to as **Distributed Generation**, has seen tremendous growth recently due to factors such as limited utility grid generation and transmission capacity combined with the onset of utility deregulation. Strong economic incentives now exist for many users to consider on-site self generation for both improved power reliability and energy cost reduction. Additionally, these opportunities have spurred the development of new and unique types of generating and switching technologies.

Cutler-Hammer Closed Transition Soft Load Automatic Transfer and Peak Shaving Switches are just such a technology. Closed transition soft load transfer switches are an ideal solution for power availability, energy management, and generator-set exercising applications. Unlike traditional open transition switches that provide a break-before-make operation, the closed transition soft load switch allows two power sources, usually the utility and a generator set, to be paralleled indefinitely. This permits the load, inductive or resistive, to be gradually and seamlessly transferred from one source to another. All of this is accomplished through the make-before-break operation of the switch with no power interruption to the load.

The Cutler-Hammer Closed Transition Soft Load Switch utilizes an integrated microprocessor based power controller to make active paralleling of two power sources possible. It manages the speed governor and voltage regulator of the generator set to bring the two sources into synchronization. This approach allows the transfer switch to be applied in soft load transfer applications. In addition, it can also be used as a peak shaving switch helping customers to reduce their peak demand charges by paralleling the generator set with the utility source during times of high electrical demand.

Standard drawout or drawout bypass isolation configurations are available with or without an integral service entrance rating. If a switch with a service entrance rating is used as service entrance equipment, the need for separate service disconnects and overcurrent protective devices is eliminated.

Cutler-Hammer Closed Transition Soft Load Automatic Transfer Switches are available for 800 through 4000 ampere, 120 to 600Vac, 50 or 60Hz applications worldwide. They are offered in both indoor (NEMA 1) and outdoor (NEMA 3R) free standing enclosures utilizing drawout insulated case Type SPB switching devices. The Type SPB switching device is a 100% rated device with a 100kA interrupting capability at 480Vac.

Applications

Power reliability and power costs are two issues of strategic importance in almost all industry segments. Businesses have critical processes that cannot tolerate a shut down, while an extended failure in many cases could cause unrecoverable losses. In addition, significant changes in the utility industry have created on-site generation opportunities for customers to address their power reliability and energy cost concerns. This type of on-site power generation at or near the point of consumption is known as distributed generation. Market studies estimate that over 40% of generation capacity added in the United States alone over the next 10 years will be distributed. A key enabler of these on-site generation systems and reliable power in general is often a closed transition soft load transfer switch.

Typical applications for Cutler-Hammer Closed Transition Soft Load Automatic Transfer Switches include industrial processes, data centers and critical care facilities. Actually, any location with critical loads where the absence of power could result in lost revenue, production time or personal injury should make this equipment a prime consideration.

Consider several specific applications:

- A facility with emergency or critical power systems wanting to test their generator sets without a power interruption.
- Any industrial, institutional or commercial business seeking ways to lower energy costs by reducing demand charges, which can represent over 50% of an electrical bill.
- Energy Service Companies interested in offering performance based solutions to their customer base.
- Electrical power providers interested in offering power reliability solutions to their customer base in return for long term electrical contracts.

The Cutler-Hammer Closed Transition Soft Load Automatic Transfer Switch can be applied in new installations or as a retrofit to replace an existing open transition transfer switch. A number of application issues should be reviewed. First, since most generator sets run on diesel fuel, there are exhaust emission concerns to consider. In some markets, the EPA (Environmental Protection Agency) limits the number of hours annually that a generator set can be operated. Methods to deal with such restrictions should they present a problem are the use of natural gas or dual fuel (natural gas/diesel mixture) types of generator sets. A second issue relates to electrical utility interconnection standards. Many utility companies require multiple levels of protective relaying when a user wishes to parallel to the utility grid. The cost of meeting some of these specifications can be high. These issues should be discussed when peak shaving is being considered.

Sequence of Operations

Automatic Mode

Loss of Normal Power

The system continuously monitors the condition of the normal power supply. When phase-to-phase or phase-to-neutral voltage of the normal source is sensed outside the user adjustable set points, and after an adjustable time delay (TDES) to override momentary dips and/or outages, a contact shall close to initiate a starting of the alternate power source. Transfer to the alternate source shall take place immediately or after a user selectable time delay (TDNE) upon attainment of adjustable pick-up voltage and frequency of the alternate source.

Return to Normal Power (Switch in Open Transfer Mode)

When the normal source has been restored and is within the pre-selected ranges of voltage and frequency, and after a time delay (TDEN) to ensure the integrity of the normal power source, the load shall be transferred back to the normal source. The generator set will continue to run for a user adjustable time (TDEC) allowing the generator set to run unloaded for cool down after which the engine will be shut down. Upon completion, the system will then be ready for automatic operation.

Return of Normal Power (Switch in Closed Transfer Mode)

When the normal source has been restored and is within the pre-selected ranges of voltage and frequency, and after an adjustable time delay (TDEN) to ensure the integrity of the normal power source, the load shall be transferred back to the normal source. On completion of the time delay, the generator set bus will automatically synchronize with the utility service across the utility transfer breaker. When the two systems are synchronized, the utility breaker will close and the generator set will gradually transfer all loads to the utility.

On completion of the load transfer sequence, the generator set transfer breaker will open. The generator set will continue to run for a user determined time (TDEC) allowing the generator set to run unloaded for cool down, after which the engine will be shut down. On completion, the system will be ready for automatic operation. Controls are provided to prevent parallel connection to the utility beyond a user adjustable period (TDUP).

Failure of Alternate Source While Carrying the Load

Failure of the alternate source while carrying the load will result in the immediate transfer to the normal source upon restoration of normal power.

Test Mode

There are two basic test mode operations. The "Engine Run" test mode starts and runs the engine unloaded. The "Transfer Test" test mode initiates a transfer of the load from Normal to Emergency in an open or closed transition mode. Tests may be programmed to operate at a user selected time each week or may be manually run.

Transfer Test Mode (Open Transfer)

To perform an open transmission transfer test, first place the Transition Mode switch in the "Open" position. Next, place the Test Mode switch in the "Transfer Test" position, followed by placing the Auto/Initiate Test switch in the "Initiate Test" position. Refer to the Automatic Mode Operation for Loss of Normal Power.

Returning either the Auto/Initiate Test switch to "Auto" or the Transfer Mode switch to "Off" will cause the system to return to normal power as described previously in Return of Normal Power (Switch in Open Transition Mode).

Transfer Test Mode (Closed Transfer)

To perform an closed transmission transfer test, first place the Transition Mode switch in the "Closed" position. Next, place the Test Mode switch in the "Transfer Test" position, followed by placing the Auto/Initiate Test switch in the "Initiate Test" position.

After an adjustable time delay (TDES), the generator will start and build up to rated speed and voltage. Following an adjustable time delay to allow the generator to stabilize (TDNE), the generator bus will be synchronized to the utility across the generator breaker. When the two sources are synchronized, the generator breaker closes and the generator will gradually assume all loads. When all loads have been transferred to the generator bus, the utility breaker will open.

Returning either the Auto/Initiate Test switch to "Auto" or the Transfer Mode switch to "Off" will cause the system to return to normal power as described previously in Return of Normal Power (Switch in Open Transition Mode).

Failure of Generator Set to Start

If the generator set fails to start after a user settable time delay (TDES), the alarm will sound and the "Fail To Sync" annunciator light will light. The system will remain connected to the normal source.

Failure of a Generator Set to Synchronize

If the generator set fails to synchronize after a user settable time delay (TDSL), the alarm will sound and the "Fail to Sync" annunciator light will light. The controls will continue to attempt to synchronize the generator to the utility until a manual intervention occurs. The synch-check relays prevent parallel connection as long as the two sources are not synchronized.

Failure of the Generator Set

A generator set failure will cause the generator set transfer breaker to open, and the "Fail to Sync" annunciator light and horn to operate. The load will then transfer back to the utility source, bypassing the time delay (TDEN), if it is available.

Sequence Flow Chart – Soft Load ATS

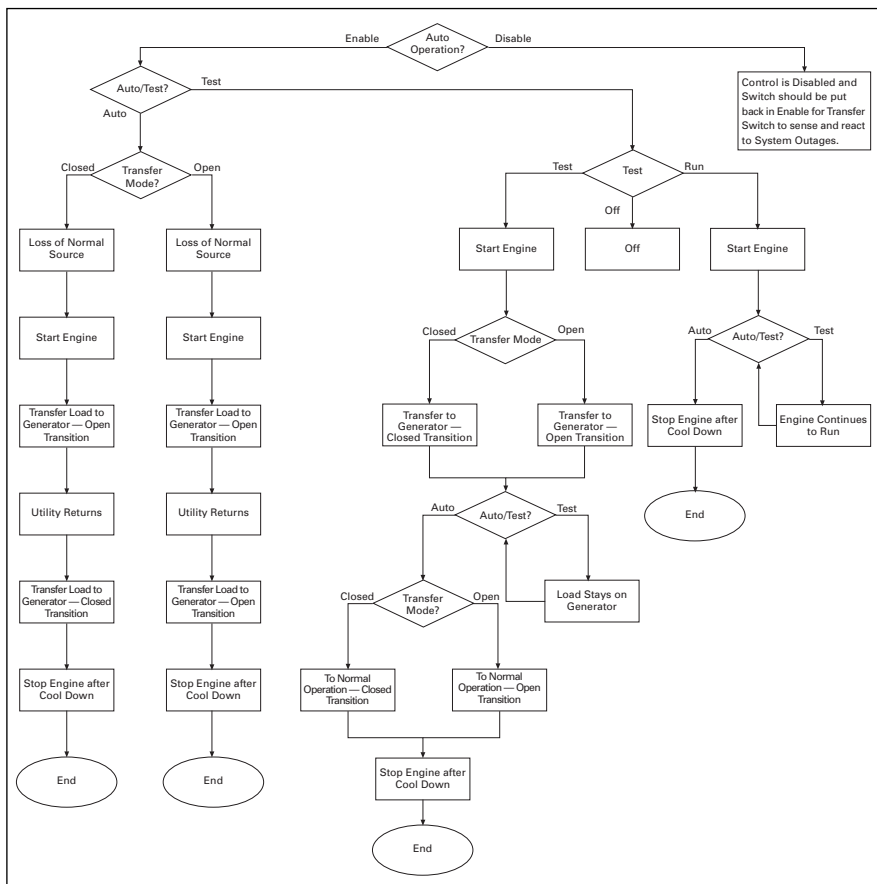

Peak Shaving Mode

The closed transition soft load transfer switch also is factory configured for paralleling applications. In this operational mode, the switch can be field set to be paralleled with the utility for an indefinite amount of time in order for the user to reduce energy costs through peak demand reduction or by providing the utility with a distributed generation source.

Technical Specifications

System

Standards

Cutler-Hammer transfer switch equipment enclosure is listed for application by UL and is certified to meet Canadian Standards by Underwriters Laboratories Inc. (CUL), except for Bypass Isolation and Service Entrance units. In addition, Cutler-Hammer Automatic Transfer Switches are listed in File E38116 by Underwriters Laboratories Inc. under standard UL 1008. All switches are also listed under UL 891.

All Cutler-Hammer Automatic Transfer Switches are available to meet NFPA 110 for emergency and stand-by power systems, and NFPA 99 for health care facilities when supplied with appropriate options.

Since Cutler-Hammer Automatic Transfer Switches utilize specially designed switches and/or circuit breakers as the main power switching contacts, these devices must also be listed under the additional UL Standard 1087.

Sequence Flow Chart – Soft Load ATS With Peaking Capabilities

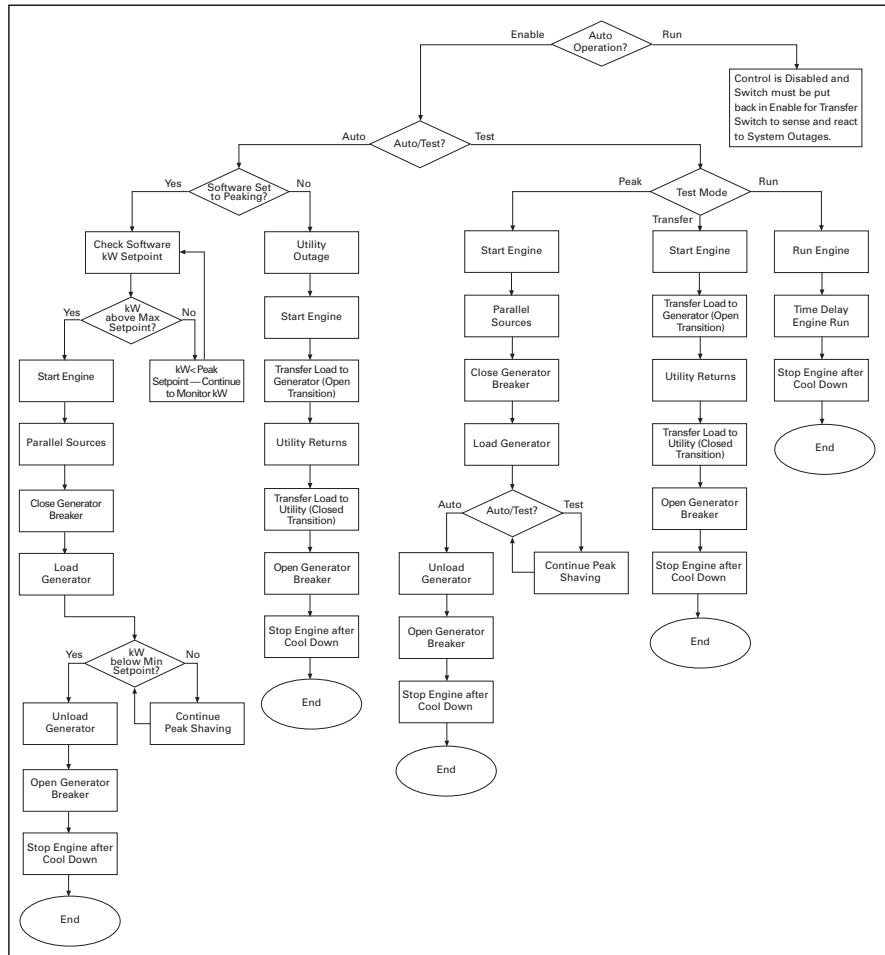

System Ratings

Standard UL1008 3 Cycle				60 Cycle, Extended Rating					
ATS Ampere Rating	Ratings when used with Upstream Breaker (kA)			Ratings when used with Upstream Fuse (kA)		Ratings used for Coordination with Upstream Breakers with Short Time Ratings			
	Volts			Maximum Fuse Rating	Fuse Type	Volts			
	240	480	600			600	240	480	600
800	100	100	85	2000	L	200	51	51	51
1000	100	100	85	2000	L	200	51	51	51
1200	100	100	85	2000	L	200	51	51	51
1600	100	100	85	3000	L	200	51	51	51
2000	100	100	85	3000	L	200	51	51	51
2500	100	100	85	4000	L	200	51	51	51
3000	100	100	85	4000	L	200	51	51	51
4000	100	100	85	-	-	-	85	85	85

SPB Drawout

800	100	100	85	2000	L	200	51	51	51
1000	100	100	85	2000	L	200	51	51	51
1200	100	100	85	2000	L	200	51	51	51
1600	100	100	85	3000	L	200	51	51	51
2000	100	100	85	3000	L	200	51	51	51
2500	100	100	85	4000	L	200	51	51	51
3000	100	100	85	4000	L	200	51	51	51
4000	100	100	85	-	-	-	85	85	85

Environmental

Seismic

With proper installation and by including the appropriate option which includes specially designed cleats, a transfer switch has a seismic capability which exceeds the worst case Zone 4 required levels per both the Uniform Building Code and the California Building Code.

Operational Conditions

Normal operation in an electrical equipment room for indoor applications. Outdoor applications subject units to falling rain, freezing temperatures, 95% humidity (non condensing).

Ambient temperature for operation between -20° and +65°C.

Typical System Diagram – Standard One Line

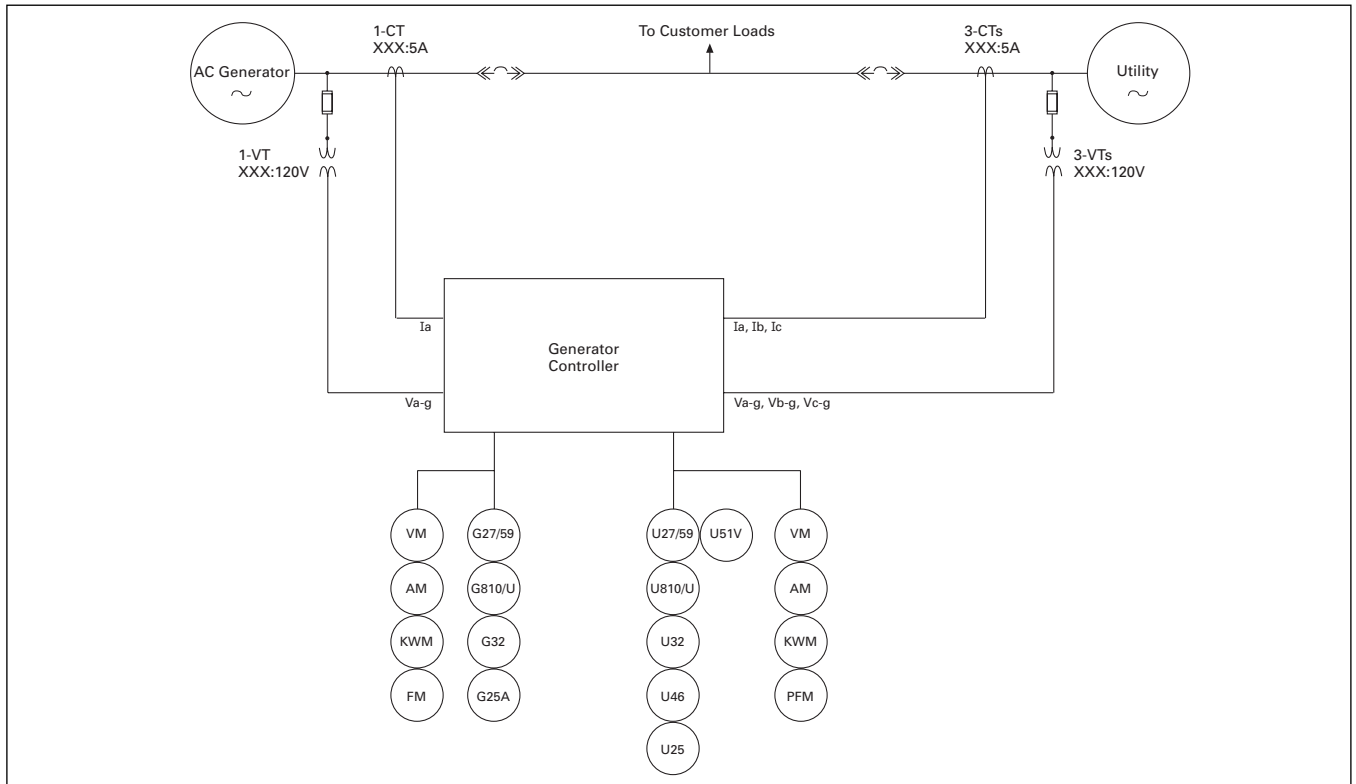

Typical System Diagram – Standard One Line With Utility Grade Multi-function Relaying

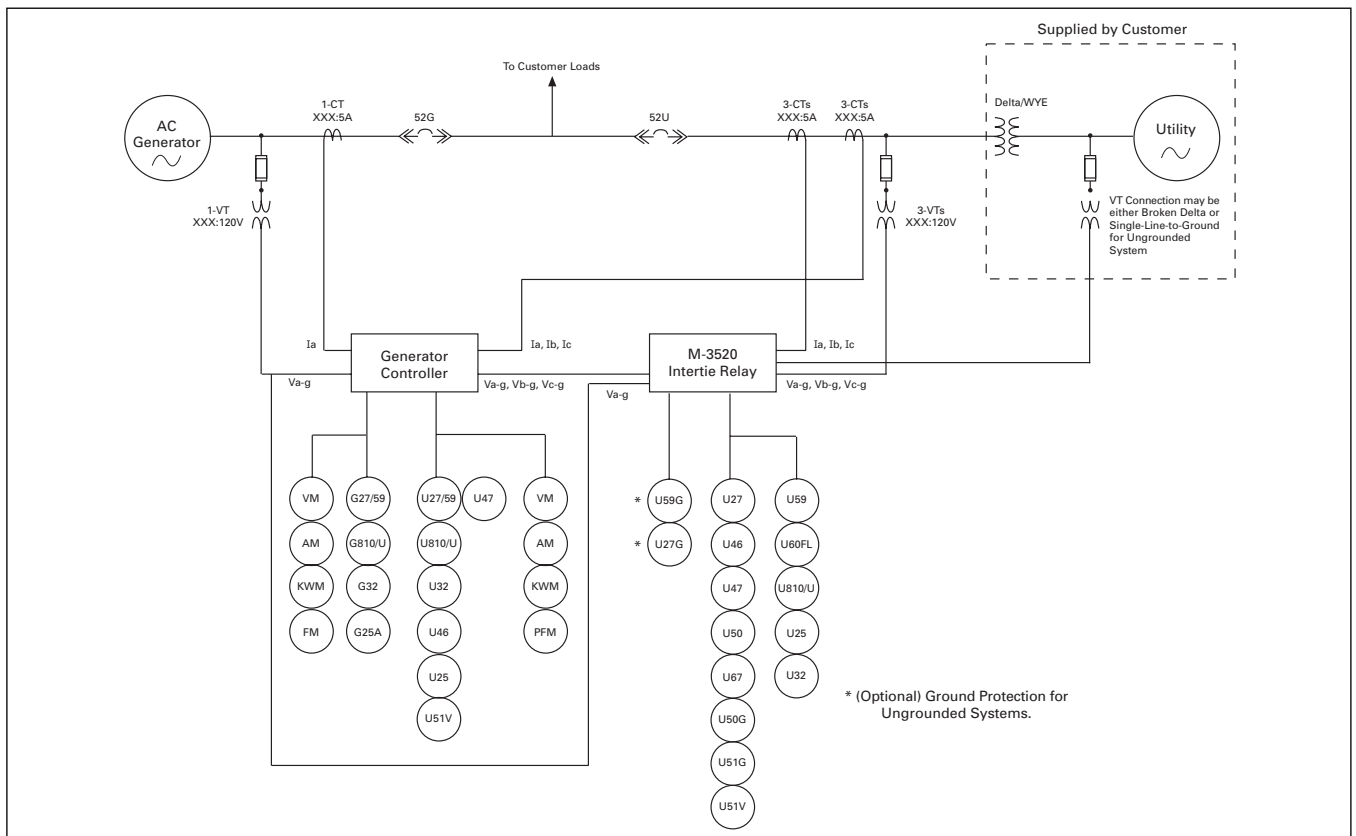

Base Components



Enclosure

Cutler-Hammer closed transition soft load transfer switches are enclosed in rugged steel free standing enclosures. All full and three-quarter height compartment doors are supplied with three door hinges to insure proper support for the door and door mounted devices. Only the smaller one-third height compartments doors have two door hinges. Hinges have removable hinge pins to facilitate door removal. All circuit breaker and microprocessor compartment doors are supplied as standard with key lockable handles. Other doors have positive twist turn latches. Doors are used to mount a variety of lights, switches, pushbuttons and other control equipment. The exact mounting configuration depends upon the options selected for a particular switch.

Transfer switch enclosures and all internal steel mounting plates are subjected to a pre-treatment cleaning system prior to painting to insure a durable finish. The enclosure and all parts subject to corrosion, other than bus or electrical connections are coated to provide additional protection in corrosive conditions.

The entrance of external conductors can be from the top or bottom of the enclosure. Cable entry holes are the customer's responsibility.

Transfer switch units are available in both indoor (NEMA 1) and outdoor (NEMA 3R) enclosures. NEMA 1 enclosures are supplied with front doors only, while NEMA 3R enclosures have front and rear doors. Enclosures meet all applicable NEMA and UL standards for conduit entry, cable bending, gutter space and shielding of live components.

Power Cables

Power cables are connected to solderless screw type lugs located on the transfer switch switching devices. The lugs supplied must match the power cables being used. For provisions to mount two hole compression connectors, contact the factory.

Wire Size for Power Cable Connections

Switch Rating (Amps)	Cables per Phase	Range Wiring Size
600-1200	4	4/0-500 MCM
1600-2000	8	4/0-500 MCM
2500-3000	12	4/0-500 MCM
4000	16	4/0-500 MCM

Buswork

As a minimum, phase and neutral conductors are sized to 1000 amperes per square inch. They consist of silver plated copper 1/4 inch by 4 inch bus bars. The ground bus utilizes a 1/4 inch by 2 inch copper bus bar as a minimum.

SPB Circuit Breakers



The main contacts connect and disconnect the load to and from the different power sources. Cutler-Hammer high withstand drawout SPB type insulated case switches provide these main contacts for the Normal and Emergency power sources in standard automatic transfer switches. Integral thermal and short circuit protection in either or both switching devices is optional. The SPB is a continuous duty device and is rated for all classes of loads. In addition, the SPB has a high dielectric strength, heavy-duty switching and withstand capabilities, and a high interrupting capacity. It is available with standard withstand ratings from 65 to 100kA. All like rating power switching devices are interchangeable.

The Cutler-Hammer SPB switches or circuit breakers used in the transfer switch can be supplied in continuous current ratings from 800 through 4000 amperes. They are available in 3 or 4-pole configurations, except for the 4000 ampere device which only available as 3-pole. The SPB is especially well suited for a system requiring any or all of the following: greater redundancy, easier maintainability and true selective coordination. Refer to the Withstand Rating Table for system coordination information.

The SPB type insulated case switches and circuit breakers used by the Cutler-Hammer transfer switches

utilize a stored-energy mechanism with an electrical operator. The electrical operator automatically recharges the mechanism after the switching device has been closed. The device has a five-cycle opening/closing speed. Indicators on the front of the switching device indicate whether it is in the OPEN or CLOSED position and the status of the stored energy mechanism. The SPB is closed by energizing a solenoid that releases the spring mechanism. A shunt trip, when energized, opens the device.

All SPB switches are available with overcurrent protection as an option. This feature should be selected whenever the switch is used for service entrance applications or when the users wants to eliminate redundant upstream protective devices. Various combinations of long time, short time, instantaneous, and ground fault protection are available.

Since the SPB is provided in a drawout configuration, the transfer switch is mechanically interlocked to the drawout mechanism to ensure that the switching device is OPEN when disconnecting it from the line and load connections. The drawout mechanism has four positions:

- CONNECTED - SPB fully connected to primary and secondary connections
- TEST - SPB connected only to secondary connections
- DISCONNECTED - SPB disconnected from both primary and secondary connections
- WITHDRAWN - SPB can be removed from its drawout cassette

Generator Controller

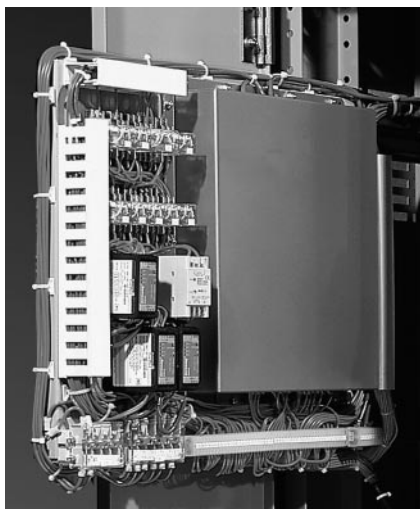

The generator controller is a microprocessor-based, PC configurable generator set management package that incorporates traditionally discrete control components. It provides for the safe and reliable transfer of power between a single generator and the utility grid.

Features include:

- Automatic Transfer Switch Logic
- Frequency and Voltage Bias Outputs for generator set
- Protective Relays
 - Device 25A Synchronizer
 - Device 27/59 O/U Voltage for generator set and utility tie
 - Device 81 O/U Frequency for generator set and utility tie
 - Device 32 O/U Direction Power
 - Device 46N Negative Phase Sequence (current)
 - Device 47N Negative Phase Sequence (voltage)
 - Device 25 Sync check
 - Device 51VR Voltage Restrained Overcurrent
 - Over/Under Reactive Power
- VAR/PF Controller
- Power Quality Monitoring
 - KW, KVAR, KVA, PF, Voltage, Current, Harmonic Distortion

The generator controller was designed to meet or exceed ANSI/IEEE C37.90-1989 and IEEE Standards for Relays and Relay Systems Associated with Electrical Power Apparatus (5000 volt surge withstand). It is recognized to U.S. and Canadian requirements under the Component Recognition Program of Underwriters Laboratories Inc. Refer to the appropriate table for electrical and operational specifications.

Specifications

Environmental

Humidity: 95% at 38° C
Temperature: -25° C to 70° C

Power Requirements

18 to 75 Vdc (<10W)
85-265 Vac (<25W)

Single Phase Potential Input

60-150 Vac
50/60 Hz
Delta, Open Delta, or
Wye Configurations

3-Phase Potential Inputs

60-150 Vac
50/60 Hz
Delta, Open Delta, or
Wye Configurations

Single Phase Current Input

0-5 Amperes
50/60 Hz

3-Phase Current Inputs

0-5 Amperes
50/60 Hz

Digital Inputs

20-40 Vac/Vdc
85-150 Vac/Vdc

Digital Outputs

1-120 Vac/Vdc
0.15 Amperes Maximum

Frequency and Voltage Bias Outputs

+/- 3 Vdc
4-20 mA

Display/Programmer

Operator Interface



Introduction

Cutler-Hammer's PanelMate D500 operator interface is used to display all metered values and allow the operator to modify relay setpoints and configure system parameters. PanelMate D500 operator interfaces feature 4 x 20 character vacuum fluorescent display and status LEDs. Operator entry is through a membrane keypad with both function and numeric keys.

Customize Faceplates

Face templates can be designed to match the application with function keys labeled and sealed under the removable keypad overlay. The application is uniquely designed using the Windows-based configuration software.

D500 Alarm Menu

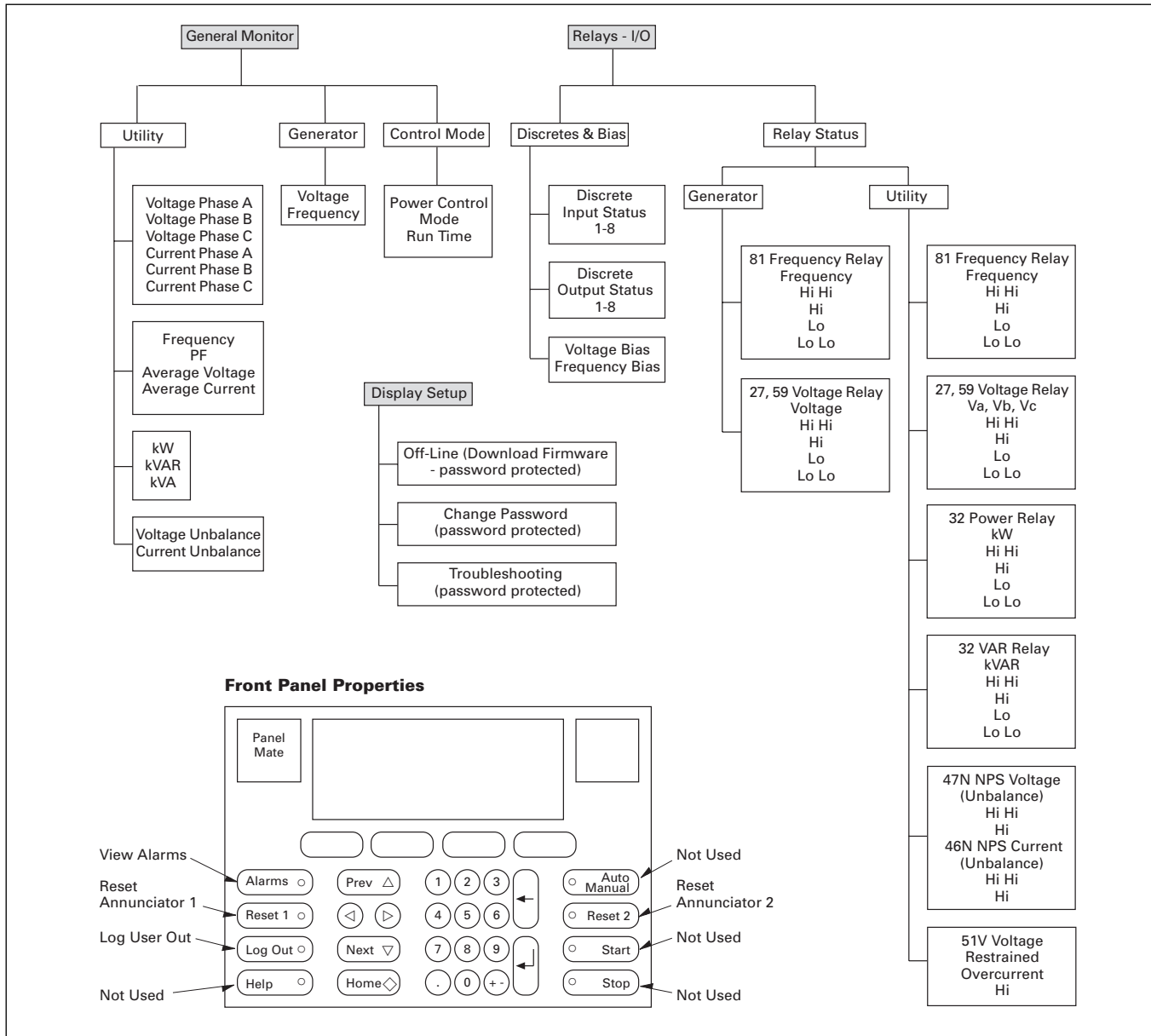

Alarm Definitions

Annunciator Block 1

Annunciator Input 01	Generator Frequency Hi Hi
Annunciator Input 02	Generator Frequency Hi
Annunciator Input 03	Generator Frequency Lo
Annunciator Input 04	Generator Frequency Lo Lo
Annunciator Input 05	Generator Voltage Hi Hi
Annunciator Input 06	Generator Voltage Hi
Annunciator Input 07	Generator Voltage Lo
Annunciator Input 08	Generator Voltage Lo Lo
Annunciator Input 09	Generator Power Hi Hi
Annunciator Input 10	Generator Power Hi
Annunciator Input 11	Generator Power Lo
Annunciator Input 12	Generator Power Lo Lo
Annunciator Input 13	Generator VARs Hi Hi
Annunciator Input 14	Generator VARs Hi
Annunciator Input 15	Generator VARs Lo
Annunciator Input 16	Generator VARs Lo Lo

Alarm Definitions

Annunciator Block 2

Annunciator Input 01	Generator Voltage Unbalance Hi Hi
Annunciator Input 02	Generator Voltage Unbalance Hi
Annunciator Input 03	Generator Current Unbalance Hi Hi
Annunciator Input 04	Generator Current Unbalance Hi
Annunciator Input 05	Generator Voltage Restrained Over Current
Annunciator Input 06	Utility Frequency Hi Hi
Annunciator Input 07	Utility Frequency Hi
Annunciator Input 08	Utility Frequency Lo
Annunciator Input 09	Utility Frequency Lo Lo
Annunciator Input 10	Utility Voltage Hi Hi
Annunciator Input 11	Utility Voltage Hi
Annunciator Input 12	Utility Voltage Lo
Annunciator Input 13	Utility Voltage Lo Lo
Annunciator Input 14	Generator Failure
Annunciator Input 15	Fail To Sync
Annunciator Input 16	Breaker Fault

D500 Operator Station Specifications

Feature	Description
Main Processor	
CPU	Motorola 68306 Microcontroller
Display	
Resolution Character Size	4x20 VFD Operator Station will have a 4 characters x 20 characters resolution 5mm
Environment	
Temperature Humidity NEMA Class Vibration	Operating Ambient Temperature 0° to 50° C; Storage Temperature -20° to 60° C 20-85% Noncondensing NEMA 4, NEMA 4X, or NEMA 12 when properly mounted in a correspondingly rated enclosure Operating: 2g at 10-500 Hz; Non-Operating: 2g at 10-500 Hz
Shock Altitude Noise Immunity ESD Immunity	Operating: 15g; Non-Operating: 30g Operating: 10,000 feet above sea level; Non-Operating: 30,000 feet above sea level NEMA ICS 2-230, Showering Arc Test IEC 801-2
Power Requirements	
Voltage Consumption	24 Vdc (18-30 Vdc) 4x20 VFD Operator Station with an optional communication interface board:460 mA at 24 Vdc
Serial Ports	
Rate	Selectable: 110 to 19,200 baud Serial Port 1 has one RJ-11 connection for RS232 communication and one RJ-45 connection for RS422 and 485-2 communication. Note that only one connection may be used at a time. Serial Port 2 has one RJ-11 connection for RS232 communication.

Annunciation



A 16-point annunciator is standard with all switches. Green, white or red lamps indicate normal operation, amber indicates impending concern or a cautionary condition. Red also indicates failure with an alarm horn sounding.

Lamps are 1 inch in diameter and are clearly visible under bright room lighting conditions. Permanent labels are provided for each alarm lamp. Standard lamps include:

- Normal Available (white)
- Emergency Available (white)
- Engine Run (white)
- Normal Open (green)
- Emergency Open (green)
- Fail to Sync (amber)
- Normal Closed (red)
- Emergency Closed (red)
- Control not in Auto (white)
- Normal Tripped (amber)
- Emergency Tripped (amber)
- Control Fault (red)
- Reverse Power Fault (amber)
- Protective Relay Fault (red)

Control Switches

The standard pilot devices used are 30mm corrosive resistant devices. Standard pilot devices supplied depend upon the specific switch configuration: soft load, soft load with peak sharing and service entrance. It is important to note that it takes a minimum of two sequential operations before the transfer switch will perform an operation. Refer to the **Operations Flow Chart** in the section entitled "SEQUENCE OF OPERATIONS".

Soft Load Configuration

The following pilot devices are standard on each unit:

- Automatic Operation Switch (enable/disable)
- Transfer Mode Switch (open/closed transition)
- Test Switch (auto/initiate test)
- Test Mode Switch (engine run/off/transfer test)
- Alarm Horn (alarm silence PB and alarm reset PB)
- Display (on/off - for use with optional touchscreen display)

Soft Load with Peak Sharing Configuration

The following pilot devices are standard on each unit:

- Automatic Operation Switch (enable/disable)

- Operation Mode (peak/transfer/run)
- Initiate Test Switch (off/on)
- Alarm Horn (alarm silence PB and alarm reset PB)
- Display (on/off - for use with optional touchscreen display)

Service Entrance Configuration

In addition to the pilot devices supplied with the soft load configuration, the following two additional devices are supplied mounted on a separate panel:

- Key Operated Selector Switch (permits external power operated disconnection)
- Pilot Light (indicating disconnection)

Optional Components

Metering

Highly accurate source and load metering can be provided for advanced energy management and power quality analysis. Meeting the stringent ANSI C12.16 Class 10 accuracy requirements, Cutler-Hammer IQ meters can measure parameters including voltage, current, power (watts, vars and VA), energy, frequency, demand, power factor, %THD (voltage and current), K factor, CBEMA derating factor, and crest factor. Each IQ meter also communicates with Cutler-Hammer's industry accepted IMPACC and Power-Net Power Management Systems.

IQ Analyzer



The IQ Analyzer is a highly accurate meter providing energy management and power quality information on an easy-to-read display. It meets ANSI C12.16 Class 10 accuracy specifications for revenue meters and is ideal for utility bill verification. It is easy to use and all programming is completed by the operator on the faceplate, with no need for a PC. The IQ Analyzer has a nonvolatile memory and provides true rms readings through the 50th harmonic and displays even or odd multiples of the fundamental current and voltage through the 50th harmonic.

In addition, the waveform display includes the ability to detect subcycle voltage disturbances, including voltage transients and subcycle voltage interruptions. Analysis screens provide detailed information on trends, recorded events/alarms, harmonic distortion, and peak demands of current and power.

IQ DP-4000



The IQ DP-4000 is a full function meter ideal for complete system monitoring. It replaces individually mounted and wired ammeters, voltmeters, ammeter and voltmeter switches, wattmeters, varmeters, power factor meters, frequency meters, watt hour and demand meters. The easy to understand and use membrane faceplate is designed and tested to perform in harsh industrial environments. It has a nonvolatile memory with energy management information, AC amperes, AC voltage, and frequency provided in the form of direct reading metered values.

In addition, protective functions include phase loss, phase unbalance, phase reversal, overvoltage, undervoltage, and delay.

Protective Relaying



For paralleling applications, additional utility grade protective relaying is optional. It is offered when utility interconnecting standards require a redundant protection level. In addition to duplicating many of the relaying features included in the generator power controller, this additional relaying package offers:

- Instantaneous Overcurrent (Device 50)
- Neutral Inverse Time Overcurrent (Device 51G)
- Neutral Instantaneous Overcurrent (Device 50G)
- Directional Overcurrent (Device 67)
- Sequence of Events Reporting
- Event Capture for Pre and Post Fault Analysis
- Over/Under Frequency (Device 81O/U)
- Negative Phase Sequence Current (Device 46)

- Negative Phase Sequence Voltage (Device 47)
- Reverse Power (Device 32)
- Undervoltage (Device 27)
- Overvoltage (Device 59)
- Sync Check (Device 25)
- Voltage Restrained Overcurrent (Device 51V)

Transient Voltage Surge Suppression (TVSS)

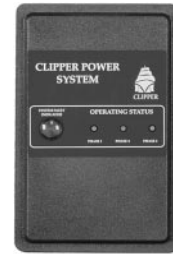

Cutler-Hammer's "Clipper Power System" (CPS) transient voltage surge suppression components can be integrated into any closed transition soft load switch. Surge current ratings from 100kA to 250kA per phase provide a range of cost effective facility-wide protection solutions. Status indication on each phase is standard with any TVSS option.

The "Clipper Power System" is available in several different models to fit increasingly higher application requirements, from economical noncritical applications to service entrance or high exposure locations. Optional diagnostic packages are available for each model. Refer to the Specifications Table for individual model details.

Cutler-Hammer Clipper Power System Specifications

CPS Models	CPS-B	CPS-H
Surge Current Per Phase	100 kA	250 kA
Surge Current Mode		
L-N (Line-to-Neutral)	50 kA	125 kA
L-G (Line-to-Ground)	50 kA	125 kA
N-G (Neutral-to-Ground)	50 kA	125 kA
L-L (Line-to Line, Delta, and Underground Applications Only)	50 kA	125 kA
Single Pulse Surge Current Test Based on IEEE C62.41 8x20 Microsecond Waveform	Yes	Yes
Modes of Protection	All	All
3-Phase Wye System	7	7
3-Phase Delta System	6	6
Filter Attenuation (Based on MIL-STD-220A) at 100 kHz	40 dB	55 dB
Surge Withstand Capabilities IEEE C3 Wave (10 kA)	>1500	3500
TVSS TRI-Monitor™ System		
Overcurrent Protection	Yes	Yes
Infrared Detection	Optional	Yes
Thermal Detection	Optional	Yes
Diagnostic Package	BD	SD
Direct Bus Bar Connection	Yes	Yes
Warranty	5 Years	5 Years

Communications

Optional communications capability is available allowing remote data access, control, system interface, and utility dispatch capabilities. Communications mediums can include direct dial-up modems, cellular modems, and Ethernet TCP/IP networking. A touch screen display is also available allowing for the user to view real time data in a graphical format, modify set points, and control system operations.

Industrial PC



D725 is a compact automation industrial PC (iPC) with an integrated drawer mounted floppy drive and hard drive providing for convenient access. Smaller than traditional iPCs, it can fit in a 9.25 inch by 6.5 inch cutout, making it one of the smallest, fully functional industrial PCs on the market. The D725 can run Windows NT 4.0, Windows 95 and Windows 98 software packages. The D725 should be selected if remote dial in access and data logging is required without the need for on-site graphical user interface.



The D720 is a compact automation iPC similar to the D725 above but with the addition of an integrated touchscreen display. A choice of operating system, hard drive and memory options provide the ability to select the right iPC for most applications. The D720 should be selected if on-site graphical user interface is desired in addition to the features above.

D725 Specifications

Operating Temperature

0° to 50°C

Storage Temperature

-10° to 60°C

Shock

Operating 5g
Non-operating 10g

Altitude

Operating 0 to 10,000 ft.
Non-operating 0 to 50,000 ft.

ESD Immunity

Air IEC 1000-4-2, Level 3
Contact IEC 1000-4-2, Level 2

Radiated Immunity

IEC 1000-4-3 27 MHz – 1 GHz

Surge Immunity

IEC 1000-4-5 B2

Radiative/Conductive Emissions

CISPR 22, Class A

Vibration

Operating 1G from 57-2000 Hz
Non-operating 2.5G from 57-2000 Hz

Power Requirements

Voltage 90-132 Vac, 180-264 Vac
Frequency 47 to 63 Hz

Power Consumption

25W Min, 55W Max Continuous

Power Available for Add-In Boards

20W Available

Certification

UL, cUL, CE

Configuration

Backplane Type	Passive Backplane
Video	ISA Video Card
Floppy Drive	Internal
Serial Ports	2: Selectable RS-232 or RS-485
Parallel Ports	1
Keyboard or Pointing Device Connector	6-pin Minidin, 5-pin Adapter
External Drive Port	1: Floppy
Dimensions (Excludes Mounting Brackets)	10"H x 11"W x 6.75"D

D720 Specifications

Operating Temperature

0° to 50°C

Storage Temperature

-10° to 60°C

Shock

Operating 5g
Non-operating 10g

Altitude

Operating 0 to 10,000 ft.
Non-operating 0 to 50,000 ft.

ESD Immunity

Air IEC 1000-4-2, Level 3
Contact IEC 1000-4-2, Level 2

Radiated Immunity

IEC 1000-4-3 27 MHz – 1 GHz

Surge Immunity

IEC 1000-4-5 B2

Radiative/Conductive Emissions

CISPR 22, Class A

Vibration

Operating 1G from 57-2000 Hz
Non-operating 2.5G from 57-2000 Hz

Power Requirements

Voltage 90-132 Vac, 180-264 Vac
Frequency 47 to 63 Hz

Power Consumption

25W Min, 55W Max Continuous

Power Available for Add-In Boards

20W Available

Certification

UL, cUL, CE

Configuration

Display	10.4" TFT Color
Backplane Type	Passive Backplane
Floppy Drive	Internal, Rear Accessible
Touchscreen	Standard
Serial Ports	1: Selectable RS-232 or RS-485; Rear Accessible
Parallel Ports	1
Keyboard Connector	6-pin Minidin, 5-pin Adapter; Rear Accessible
External Drive Port	1: Floppy
Pointing Device	Touchscreen

Software

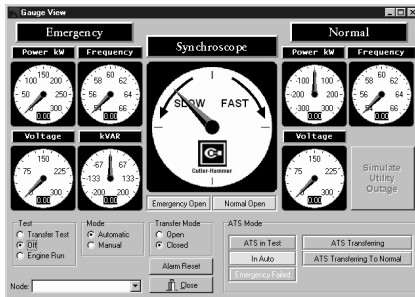

Customer software is available as:

- Local Customer Interface Software
- Remote Customer Interface Software

Local Monitoring Software

The Local Customer Interface Software provides the user with site-specific engine and generator metering and monitoring. It provides detailed information such as energy demand metering, harmonics metering and alarm log. The LCIS also provides automatic engine/generator load testing capability, manual engine start/stop and load/unload functions. It will automatically log and notify the user via alphanumeric pager in the event of an alarm. An enhanced version of LCIS is available which adds the capability to log and trend data. Data logging features include the ability to select parameters to be logged and the intervals in which data is stored.

Remote Monitoring Software

The Remote Customer Interface Software provides the same features and functionality as the LCIS software, but adds a remote access capability. Alarm notification is included. An enhanced version is also available providing for data logging and graphical trending.

Optional Features

Service Entrance

When the transfer switch is applied as a service equipment device, the need for separate service disconnects and overcurrent protective devices is eliminated. Refer to the Service Entrance Application illustration.

This optional feature provides the transfer switch as suitable for a service equipment rating. A key operated selector switch permits external power operated service disconnection with a pilot light providing external indication of the disconnect.

The option is available with or without ground fault protection. Integral overcurrent protection is provided by means of the power switching device.

Installation Comparison

Conventional Method...

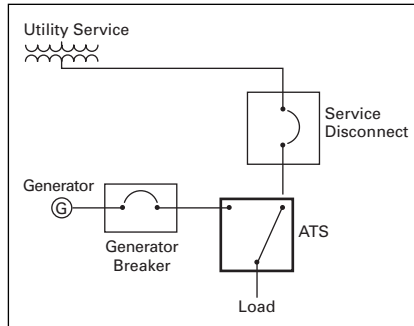

- UL 1008 Listed ATS
- Separate Generator Breaker
- Separate Generator Breaker Enclosure
- Separate Service Disconnect
- Separate Service Disconnect Enclosure
- Power Cable/Bus Interconnections
- Installation of the Separate Components
- Extra Space Requirement
- Added Maintenance Requirement

Cutler-Hammer Method...

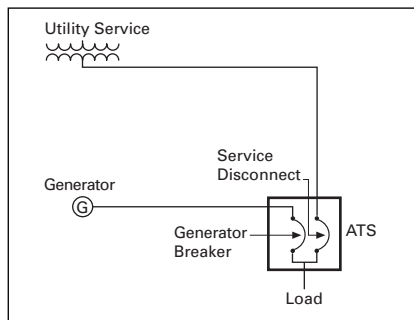

- ATS with Service Equipment Features
- UL 1008 Listed for Service Equipment
- Service Disconnect "both-off" Capability
- Integral Overcurrent Protection
- Lockout (When in disconnect position only)
- Indication of Service Disconnect
- Integrated Design
- Disconnecting Neutral Assembly
- Ground Fault Protection Capability—All Ratings (Required by code on ratings 480V and 1000A or higher)

Bypass Isolation

The bypass isolation switch is designed for applications where maintenance, inspection and testing must be performed while maintaining continuous power to the load. Such a design allows for the quick removal of different switching devices for inspection, maintenance or replacement. Refer to the graphic illustration of a typical bypass isolation switch configuration.

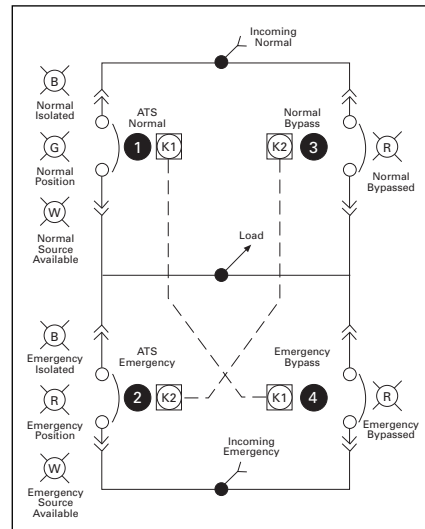

Single Line Diagram of SPB Draw-out Bypass Isolation Automatic Transfer Switch.

The following bypass functions are provided:

- Normal to Normal Bypass
- Emergency to Emergency Bypass
- Normal Bypass to Emergency Bypass
- Emergency Bypass to Normal Bypass

Setpoints and Adjustments

Generator Controller ATS Functions

Time Delay Emergency Start (TDES)

This configuration sets the Time Delay Emergency Start Configuration (aka: Gen Start Delay) in seconds. This value sets the amount of delay time between the Normal Source failure until the start signal is sent to the Emergency Source.

Time Delay Normal to Emergency (TDNE)

This configuration sets the Time Delay Normal to Emergency Configuration (aka: Gen Stable Delay) in seconds. This value sets the amount of delay time that the emergency source must be available before a transfer is initiated.

Time Delay Emergency to Normal (TDEN)

This configuration sets the Time Delay Emergency to Normal Configuration (aka: Retransfer Delay) in seconds. This value sets the amount of delay time that the normal source must be available before a retransfer is initiated.

Time Delay Neutral (TDN)

This configuration sets the Time Delay Neutral Configuration (aka: Transfer Delay) in seconds. This value sets the amount of delay time between opening the normal breaker and closing the emergency breaker during an open transfer (and vice versa on an open retransfer).

Time Delay Crank Limit (TDCL)

This configuration sets the Time Delay Crank Limit (aka: Gen Fail to Start Delay) in seconds. This value sets the amount of time allowed for the emergency source to start. This timer is started when the Start Signal is sent to the Emergency source. If the Emergency Source is not available when the timer expires, the ATS fails the emergency source.

Time Delay Emergency Cooldown (TDEC)

This configuration sets the Time Delay Emergency Cooldown (aka: Gen Stop Delay) in seconds. This value sets the amount of time to cooldown the emergency source. This timer is started when a retransfer to normal source is completed. When the timer is expired, the Emergency Start signal is turned OFF.

Generator Controller Relay Setpoints^①

Refer to the following table to make setpoint changes to the generator controller.

Name	Default
25A Sync Check Relay	
Voltage Accept Window	5.0 V
Phase Accept Window	0.175 rad
Frequency Slip Accept Window	0.025 Hz
Breaker Close Time	0.10 sec
Synchronizer Time Out	120 sec
Enable Deadbus Closing	0
Deadbus Closing Delay	1.0 sec
Enable Slip Frequency Synchronizing	0
Slip Frequency Setpoint	0.00 Hz
Synchronizer Proportional Gain Kp	0.100
Synchronizer Integral Gain Ki	50
Phase Offset Calibration	0.0145 rad
Volt Matching Proportional Gain Kp	0.200
Volt Raise/Lower Rate (%output)/sec	0.030%
27/58 Voltage Relay 1 Phase	
High High Limit	550 V
High Limit	615 V
Low Limit	470 V
Low Low Limit	460 V
Set Time for Hi, Lo, HiHi, and LoLo	1.00 sec
Clear Time for Hi, Lo, HiHi and LoLo	1.00 sec
HiHi, Lo and LoLo Hysteresis	5.00 V
Invert Outputs	0
27/58 Voltage Relay 3 Phase	
High High Limit	550 V
High Limit	515 V
Low Limit	470 V
Low Low Limit	460 V
Set Time for Hi, Lo, HiHi, LoLo	1.00 sec
Clear Time for Hi, Lo, HiHi and LoLo	1.00 sec
HiHi, Lo and LoLo Hysteresis	5.00 V
Invert Outputs	0
32 Directional Power Relay	
High High Limit	525,000 W
High Limit	500,000 W
Low Limit	-10,000 W
Low Low Limit	-20,000 W
Set Time for Hi, Lo, HiHi, and LoLo	1.00 sec
Clear Time for Hi, Lo, HiHi and LoLo	30.0 sec
HiHi, Lo and LoLo Hysteresis	5000 W
Invert Outputs	0

Name	Default
51 Voltage Restrained Overcurrent Relay	
Set Time	1.0 sec
Clear Time	1.0 sec
Voltage Level	480 V
Over Current Setpoint	560 A
Invert Outputs	0
47 Negative Phase Sequence Relay - Voltage	
High High Limit	100 V
High Limit	50 V
Set Time for Hi and HiHi	1.00 sec
Clear Time for Hi and HiHi	1.00 sec
HiHi Hysteresis	5.00 V
Invert Outputs	0
46 Negative Phase Sequence Relay - Current	
High High Limit	10 A
High Limit	5 A
Set Time for Hi and HiHi	1.00 sec
Clear Time for Hi and HiHi	1.00 sec
HiHi Hysteresis	1.0 A
Invert Outputs	0
Directional VAR Relay	
High High Limit	500,000 VAR
High Limit	400,000 VAR
Low Limit	-10,000 VAR
Low Low Limit	-20,000 VAR
Set Time for Hi, HiHi, Lo and LoLo	1.00 sec
Clear Time for Hi, HiHi, Lo and LoLo	30.0 sec
HiHi, LoLo and Lo Hysteresis	5000 VAR
Invert Outputs	0
81 Frequency Relay - Generator	
High High Limit	65.0 HZ
High Limit	61.0 HZ
Low Limit	59.0 HZ
Low Low Limit	55.0 HZ
Set Time for Hi, HiHi, Lo and LoLo	1.00 sec
Clear Time for Hi, HiHi, Lo and LoLo	1.00 sec
Lo, LoLo and HiHi Hysteresis	0.20 HZ
Invert Outputs	0
81 Frequency Relay - Utility	
High High Limit	65.0 HZ
High Limit	61.0 HZ
Low Limit	59.0 HZ
Low Low Limit	55.0 HZ
Set Time for Hi, HiHi, Lo and LoLo	1.00 sec
Clear Time for Hi, HiHi, Lo and LoLo	1.00 sec
HiHi, Lo and LoLo Hysteresis	0.20 HZ
Invert Outputs	0

① Units are shipped with factory settings set at the time of testing. A relay coordination study is required to determine exact settings for the user's specific application.

M3520 Intertie Protective Relay Setpoints^①

Refer to the appropriate table to make protective relaying changes.

Standard Functions

Device Number	Function	Setpoint Ranges	Increment	Accuracy ^②
Undervoltage				
27	Pickup #1, #2 Time Delay #1, #2	5 to 180V 1 to 8160 Cycles	1V 1 Cycle	±0.5V or ±0.5% -1 to +3 Cycles or ±1%
Negative Sequence Overcurrent				
46	Definite Time Pickup Time Delay	0.10 to 20.00A (0.02 to 4.00A) 1 to 8160	0.01A 1 Cycle	±0.1A or ±3% (±0.02A or ±3%) -1 to +3 Cycles or ±3%
	Inverse Time Pickup	0.50 to 5.00A (0.10 to 1.00A)	0.01A	±0.1A or ±3% (±0.02A or ±3%)
	Characteristic Curves	Definite Time/ Inverse/ Very Inverse/ Extremely Inverse/ IEC Curves		
	Time Dial	0.5 to 11.0 0.05 to 1.10 (IEC Curves)	0.1 0.01	±3 cycles or ±5%
Negative Sequence Overvoltage				
47	Pickup #1, #2 Time Delay #1, #2	5 to 180V 1 to 8160 Cycles	1V 1 Cycle	±0.5V or ±0.5% -1 to +3 or ±1%
Instantaneous Phase Overcurrent				
50	Pickup Time Delay	1.0 to 240.0A (0.2 to 48.0A) 2 Cycles	0.1A -	±0.1A or ±3% (±0.02 or ±3%) ±2 Cycles
Instantaneous Neutral Overcurrent				
50G	Pickup Time Delay	0.5 to 240.0A (0.1 to 48.0A) 2 Cycles	0.1A -	±0.1A or ±3% (±0.02 or ±3%) ±2 Cycles
	The 50G can be supervised by the ground directional element (if 67N option is selected).			
Inverse Time Neutral Overcurrent				
51G	Pickup	0.25 to 12.00A (0.05 to 2.40A)	0.01A	±0.1A or ±3% (±0.02A or ±3%)
	Characteristic Curves	Definite Time/ Inverse/ Very Inverse/ Extremely Inverse/ IEC Curves		
	Time Dial	0.5 to 11.0 0.05 to 1.10 (IEC Curves)	0.1 0.01	±3 cycles or ±5%
	The 51G can be supervised by the ground directional element.			
Inverse Time Overcurrent with Voltage Control or Voltage Restraint				
51V	Pickup	0.50 to 12.00A (0.10 to 2.40A)	0.01A	±0.1A or ±3% (±0.02A or ±3%)
	Characteristic Curves	Definite Time/ Inverse/ Very Inverse/ Extremely Inverse/ IEC Curves		
	Time Dial	0.5 to 11.0 0.05 to 1.10 (IEC Curves)	0.1 0.01	±3 Cycles or ±5%
	Voltage Control (VC) or Voltage Restraint (VR)	5 to 180V Linear Restraint	1V -	±0.5V or ±5% -
Overvoltage				
59	Pickup #1, #2 Time Delay #1, #2	5 to 180V 1 to 8160 Cycles	1V 1Cycle	±0.5V or ±0.5% -1 to +3 Cycles or ±1%
VT Fuse-Loss Detection				
60FL	A VT fuse loss condition is detected by using the positive and negative sequence components of the voltages and currents. VT fuse loss output can be initiated from internally generated logic or from input contacts.			
	Time Delay	1 to 8160 Cycles	1 Cycle	-1 to +3 Cycles or ±1%

① Units are shipped with factory settings set at the time of testing. A relay coordination study is required to determine exact settings for the user's specific application.

② Select the greater of these accuracy values.

Values in parentheses apply to 1 Ampere CT secondary rating.

M3520 Intertie Protective Relay Setpoints, *Continued*

Standard Functions, *Continued*

Device Number	Function	Setpoint Ranges	Increment	Accuracy ^①
Phase Directional Overcurrent				
67	Definite Time ^② Pickup Time Delay	1.0 to 240.0A (0.2 to 48.0A) 1 to 8160 Cycles	0.1A 1 Cycle	±0.1A or 3% (±0.02A or 3%) -1 to +3 Cycles or ±1%
	Inverse Time Pickup	0.050 to 12.00A (0.10 to 2.40A)	0.01A	±0.1A or ±3% (±0.02A or ±3%)
	Characteristic Curves Time Dial	Definite Time/ Inverse/ Very Inverse/ Extremely Inverse/ IEC Curves		
		0.5 to 11.0 0.05 to 1.10 (IEC Curves)	0.1 0.01	±3 Cycles or ±5%
	Phase Directional Element Maximum Sensitivity (Torque) Angle (MSA)	0°-359°	1°	
Directional sensing for 67DT or 67IT may be disabled. Sensitivity at MSA is 0.5 VA, uses Positive Sequence Voltage and current for polarization, predefault memory 8 Cycles.				
Reconnect Enable Time Delay				
79	Reconnect Delay	1-8160 Cycles	1 Cycle	-1 to +3 Cycles or ±1%
	Reconnect timer starts when all outputs designated as trip outputs dropout.			
Frequency				
81	Pickup #1, #2, #3, #4	50.00 to 67.00 Hz 40.00 to 57.00 Hz ^③	0.01 Hz	±0.02 Hz
	Time Delay #1, #2, #3, #4	2 to 65,500 Cycles	1 Cycle	-2 to +3 Cycles or ±1%
The pickup accuracy applies to 60 Hz models at a range of 57 to 63 Hz, and to 50 Hz models at a range of 47 to 53 Hz. Beyond these ranges, the accuracy is ±0.1 Hz.				

① Select the greater of these accuracy values.
 ② High speed operation results when delay programmed for one cycle; response time = less than 1-1/2 cycles.
 ③ This range applies to 50 Hz nominal frequency models.

Values in parentheses apply to 1 Ampere CT secondary rating.

M3520 Intertie Protective Relay Setpoints, *Continued*

Optional Functions

Device Number	Function	Setpoint Ranges	Increment	Accuracy ^①
Phase Distance (Dual-Zone MHO Characteristic)				
21	Circle Diameter #1, #2	0.1 to 100.0 Ω (0.5 to 500.0 Ω)	0.1 Ω	±0.1 Ω or ±5% (±0.5 Ω or ±5%)
	Offset #1, #2	-100.0 to 100.0 Ω (-500.0 to 500.0 Ω)	0.1 Ω	±0.1 Ω or 5% (±0.5 Ω or 5%)
	Impedance Angle #1, #2	0° to 90°	1°	±1°
	Time Delay #1, #2	1 to 8160 Cycles	1 Cycle	-1 to +3 Cycles or ±1%

Sync Check

25	Phase Angle Window	0° to 90°	1°	±1°
	Upper Voltage Limit	100 to 140V	1V	±0.5V or ±0.5%
	Lower Voltage Limit	90 to 120V	1V	±0.5V or ±0.5%
	Delta Voltage Limit	1.0 to 50.0V	0.1V	±0.5V
	Delta Frequency Limit	0.001 to 0.500 Hz	0.001 Hz	±0.0007 Hz or 5%
	Sync Check Time Delay	1 to 8160	1 Cycle	-1 to +3 Cycles or ±1%
	Dead Voltage Limit	0 to 60V	1V	±0.5V
	Dead Time Delay	1 to 8160	1 Cycle	-1 to +3 Cycles or ±1%
Sync Check may be operated as a stand-alone function or supervised by 79 (reconnect). Various combinations of input supervised hot/dead closing schemes may be selected.				

Neutral Undervoltage

27G	Magnitude Time Delay	5 to 180V 1 to 8160 Cycles	1V 1 Cycle	±0.5V or ±0.5% -1 to +3 Cycles or ±1%
-----	-------------------------	-------------------------------	---------------	--

Reverse/ Forward Power

32	Pickup #1, #2 Time Delay #1, #2	-3.000 to +3.000 pu 1 to 8160 Cycles	0.001 pu 1 Cycle	±0.002 pu or 2% +16 Cycles or ±1%
	The per-unit pickup is based on nominal VT secondary voltage and nominal CT secondary current settings. Single phase detection may be selected for line-to-ground connected VTs.			

Neutral Overvoltage

59G	Pickup Time Delay	5 to 180V 1 to 8160 Cycles	1V 1 Cycle	±0.5V or ±0.5% -1 to +3 Cycles or ±1%
-----	----------------------	-------------------------------	---------------	--

Peak Overvoltage

59I	Magnitude Time Delay	1.05 to 1.50 pu 1 to 8160 Cycles	0.01 pu 1 Cycle	±0.03 pu ^② -1 to +3 Cycles or ±1%
	Instantaneous voltage magnitude response; intended for ferroresonance protection.			

Residual Directional Overcurrent

67N	Definite Time ^③ Pickup Time Delay	0.5 to 240.0A (0.1 to 48.0A)	0.1A	±0.1A or 3% (±0.02A or ±3%)
		1 to 8160	1 Cycle	-1 to +3 Cycles or ±1%
	Inverse Time ^③ Pickup Characteristic Curves Time Dial	0.25 to 12.00A (0.05 to 2.40A)	0.01A	±0.1A or ±3% (±0.02A or ±3%)
		Definite Time/ Inverse/ Very Inverse/ Extremely Inverse/ IEC Curves		
		0.5 to 11.0 0.05 to 1.10 (IEC Curves)	0.1 0.01	±3 Cycles or ±5%
Ground Directional Element Maximum Sensitivity Angle (MSA) Polarization ^④	0°-359° 1-5	1° 1		

① Select the greater of these accuracy values.
② For fundamental (60 Hz/50 Hz) signal only. For distorted input signals, the accuracy degrades as the order of the harmonic signal increases. The accuracy applies to voltages below 180V.

③ Directional control for 67NDT or 67NIT may be disabled.
④ Polarization can be zero sequence, negative sequence, current (polarized), or dual polarized.

Values in parentheses apply to 1 Ampere CT secondary rating.

M3520 Intertie Protective Relay Setpoints, *Continued*

Optional Functions, *Continued*

Device Number	Function	Setpoint Ranges	Increment	Accuracy ^①
Rate of Change of Frequency				
81R	Pickup #1, #2	0.10 to 20.00 Hz/S	0.01 Hz/S	±0.05 Hz or ±5%
	Time Delay #1, #2	1 to 8160 Cycles	1 Cycle	+20 Cycles
	Negative Sequence Voltage Inhibit	0 to 99%	1%	±0.5%

Nominal Settings

	Nominal Voltage	60 to 140V	1V	–
	Nominal Current	0.5 to 6.00A	0.01A	–
	VT Configuration	Line-Line Line-Ground Line-Ground to Line-Line ^②		
	Seal-In Delay	2 to 8160 Cycles	1 Cycle	-1 to +3 Cycles or ±1%

① Select the greater of these accuracy values.

② When line-ground to line-line is selected, the relay internally calculates the line-line voltage from the line-ground voltages for all voltage-sensitive functions. This line-ground to line-line selection should only be used to a VT nominal secondary voltage of 69V (not 120V).

Values in parentheses apply to 1 Ampere CT secondary rating.

Dimensions

Refer to the applicable table and outline drawing for typical weight and dimensional information.

Plan View (Dimensions In Inches)

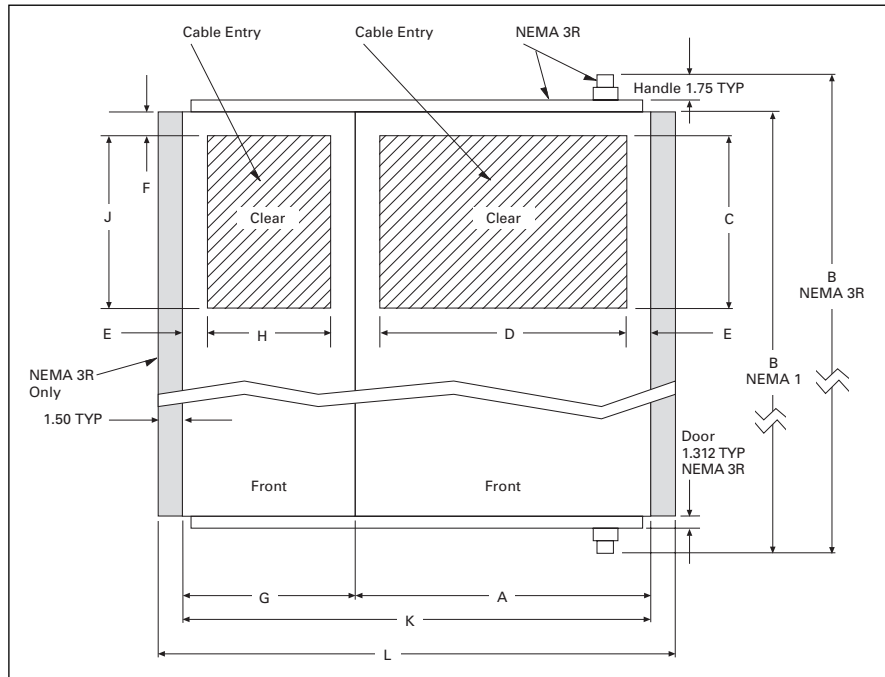

Description	Amperes	Poles	A	B Overall Dimensions	C	D	E	F	G	H	J	K	L
NEMA 1	800-2000	3	28	61.75	28.4	23.5	2.25	2.25	18	13.5	28.4	46	-
	800-2000	4	34	61.75	28.4	29.5	2.25	2.25	18	13.5	28.4	52	-
	3000	3	48	73.75	29.6	43.5	2.25	2.25	18	13.5	29.6	66	-
	4000	3	48	73.75	29.6	43.5	2.25	2.25	34	29.5	29.6	82	-
NEMA 3R	800-2000	3	28	67.63	24	22	3	2	34	28	36	-	71
	800-2000	4	34	67.13	24	28	3	2	34	28	36	-	65
	3000	3 and 4	48	79.13	24	42	3	2	34	28	36	-	85
	4000	3 and 4	48	79.13	24	42	3	2	34	28	36	-	85

Catalog Number Selection Guide

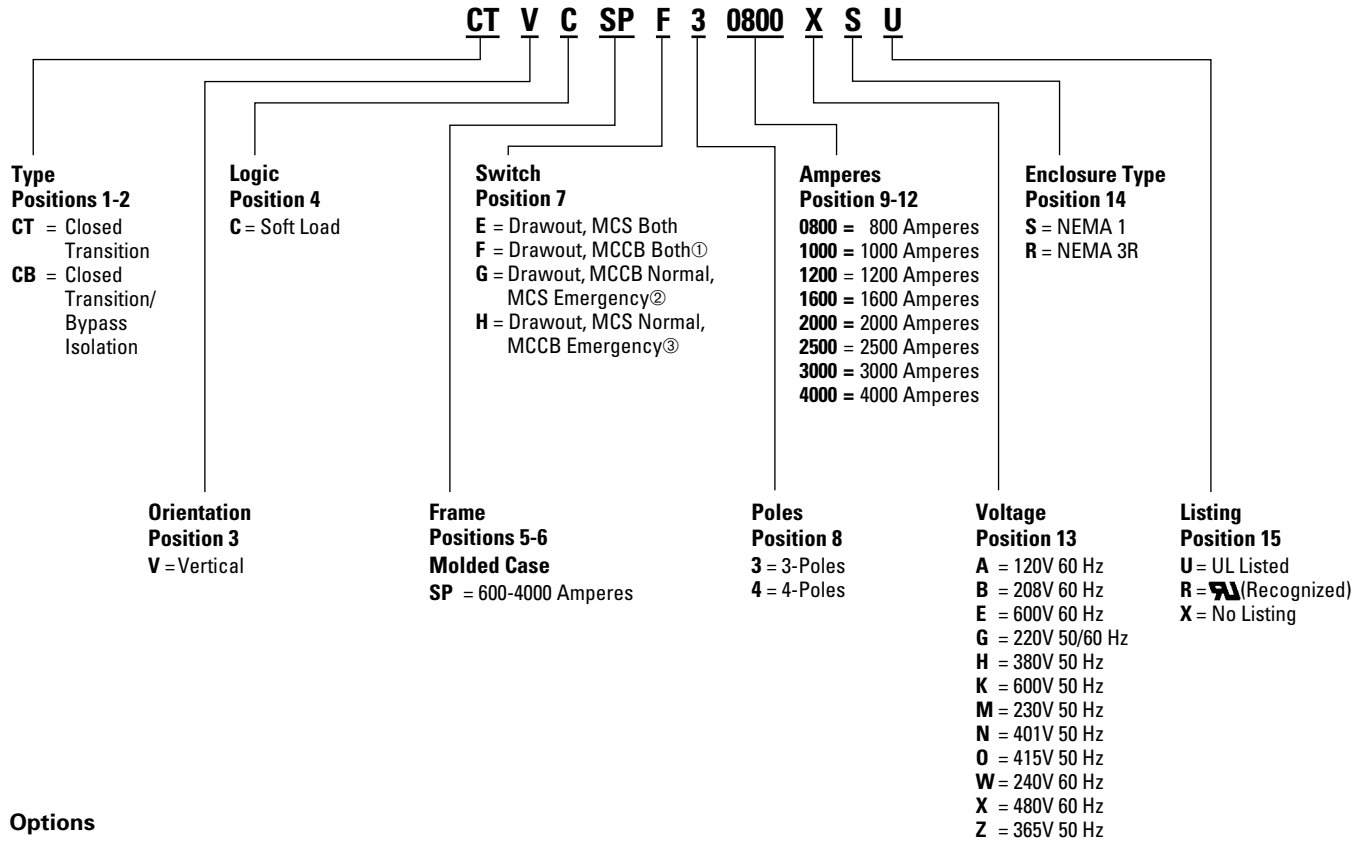

Options

Service Entrance Rating

16N	Overcurrent Protection - Normal (16N)
16E	Overcurrent Protection - Emergency (16E)
16B	Overcurrent Protection - Both (16B)
37A	Service Entrance (37A)
37B	Service Entrance with Ground Fault (37B)

Metering

18O	IQ Analyzer - Normal
18P	IQ Analyzer - Emergency
18Q	IQ Analyzer - N/E Selectable
18R	IQDP4000 - Normal
18S	IQDP4000 - Emergency
18T	IQDP4000 - N/E Selectable

Plant Exerciser

23G	Selectable Load/No Load
-----	-------------------------

Surge Protection

51A	100 kA Transient Voltage Surge Suppression (TVSS)
51B	200 kA Transient Voltage Surge Suppression (TVSS)

Protective Devices

53A	Beckwith M-3520 Protective Relay
53B	Schweitzer SEL-351 Protective Relay

Communications and Software

54A	Graphic User Interface and Touchscreen Display
54B	Dial In/Out, Alarm, and Maintenance Software

① Requires addition of Option 16B.
 ② Requires addition of Option 16N.
 ③ Requires addition of Option 16E.

Appendix A

Protective Relays

ANSI/IEEE Number	Function	Generator Controller	Cutler-Hammer Digitrip (Optional)	Beckwith M3520 (Optional)
27	Undervoltage	X		X
59	Overvoltage	X		X
32	Reverse Power	X		X
81O/U	Over/Under Frequency	X		X
25	Synch Check	X		X
46	Negative Sequence Overcurrent	X		X
47	Negative Sequence Voltage	X		X
50	Inst. Overcurrent		X	X
51	AC Time Overcurrent Relay		X	
67	Directional AC Time Overcurrent Relay			X
50N	Inst. Ground Overcurrent		X	X
51N	AC Time Ground Overcurrent Relay		X	X
51V	Voltage Restrained Overcurrent	X		X
59G	Neutral Overvoltage			X
27G	Neutral Undervoltage			X
60FL	VT Fuse-Loss Detection Provides Generator Protection Provides Utility Protection	X X	X X	X X



Appendix B

kW to Ampere Conversion Chart

Three-Phase Ampere Table at Common Line-to-Line Voltage											
kW ^①	200V	208V	220V	230V	240V	380V	400V	415V	460V	480V	600V
5.0	18	17	16	16	15	9	9	9	8	8	6
7.5	27	26	25	24	23	14	13	13	12	11	9
10.0	36	34	33	31	30	19	18	17	16	15	12
15.0	54	52	49	47	45	28	27	26	24	23	18
20.0	72	69	66	63	60	38	36	35	31	30	24
25.0	90	87	82	78	75	47	45	43	39	38	30
30.0	108	104	98	94	90	57	54	52	47	45	36
40.0	144	139	131	126	120	76	72	70	63	60	48
50.0	180	173	164	157	150	95	90	87	78	75	60
60.0	217	208	197	188	180	114	108	104	94	90	72
75.0	271	260	246	235	226	142	135	130	118	113	90
80.0	289	278	262	251	241	152	144	139	126	120	96
100.0	361	347	328	314	301	190	180	174	157	150	120
125.0	451	434	410	392	376	237	226	217	196	188	150
150.0	541	520	492	471	451	285	271	261	235	226	180
175.0	631	607	574	549	526	332	316	304	275	263	210
200.0	722	694	656	628	601	380	361	348	314	301	241
250.0	902	867	820	784	752	475	451	435	392	376	301
300.0	1083	1041	984	941	902	570	541	522	471	451	361
350.0	1263	1214	1148	1098	1052	665	631	609	549	526	421
400.0	1443	1388	1312	1255	1203	760	722	696	628	601	481
500.0	1804	1735	1640	1569	1504	950	902	870	784	752	601
600.0	2165	2082	1968	1883	1804	1140	1083	1043	941	902	722
700.0	2526	2429	2296	2197	2105	1329	1263	1217	1098	1052	842
800.0	2887	2776	2624	2510	2406	1519	1443	1391	1255	1203	962
900.0	3248	3123	2952	2824	2706	1709	1624	1565	1412	1353	1083
1000.0	3609	3470	3280	3138	3007	1899	1804	1739	1569	1503	1203

① At 0.8 Power Factor.