



# Cutler-Hammer

## Magnum Closed Transition Soft Load Transfer Switches

Technical Data

### New Information

<i>Description</i>	<i>Page</i>
General Information . . . . .	2
Receiving, Handling, and Storage . . . . .	2
General Description . . . . .	3
Applications . . . . .	3
Sequence of Operations . . . . .	4
Technical Specifications . . . . .	7
Transfer Switch Catalog Number Identification . . . . .	10
ATS-5000 Integrated Microprocessor Controller . . . . .	11
Optional Features . . . . .	13
Appendices . . . . .	15



## General Information

Transfer switches are used to protect critical electrical loads against loss of power. The Source 1 power source of the load is backed-up by a Source 2 power source. A transfer switch is connected to both the Source 1 and Source 2 power sources and supplies the load with power from one of these two sources. In the event that power is lost from the Source 1 power source, the transfer switch transfers the load to the Source 2 power source. This transfer can be automatic or manual, depending upon the type of transfer switch equipment being used. Once Source 1 power is restored, the load is automatically or manually transferred back to the Source 1 power source, again depending upon the type of transfer equipment being used.

In addition, the Eaton closed transition transfer switch may be applied where it is desirable to avoid any momentary power interruptions. Although the closed transition switch is not a substitute for an uninterruptable power source (UPS), it does eliminate power interruptions to loads except to those caused by power sources or equipment external to the transfer switch. If both sources are acceptable as determined by the IQ Transfer logic, a make-before-break transfer is performed during a transfer test or retransfer operation.

### Transfer Switch Types

There are four types of transfer switch equipment.

#### *Automatic Transfer Switch*

Automatic transfer switches (ATSs) automatically perform the transfer function. They consist of three basic elements:

1. Main contacts to connect and disconnect the load to and from the source of power.
2. Intelligence/supervisory circuits to constantly monitor the condition of the power sources and thus provide the intelligence necessary for the switch and related circuit operation.
3. A transfer mechanism to effect the transfer of the main contacts from source to source.

## Receiving, Handling, and Storage

### Receiving

Every effort is made to ensure that the transfer switch equipment arrives at its destination undamaged and ready for installation. Crating and packing is designed to protect internal components as well as the enclosure. Transfer switch enclosures are skid mounted and suited for fork lift movement. Care should be exercised, however, to protect the equipment from impact at all times. Do not remove the protective packaging until the equipment is at the installation location and ready for installation.

When the transfer switch equipment reaches its destination, the customer should inspect the shipping container for any obvious signs of rough handling and/or external damage incurred during transportation. Record any external and internal damage observed for reporting to the transportation carrier and Eaton, once a thorough inspection is completed. All claims should be as specific as possible and include the Shop Order and General Order numbers.

A shipping label is affixed to the top of the shipping container which includes a variety of equipment and customer information, such as General Order Number (GO #) and Catalog Number (Cat #). Make certain that this information matches other shipping paper information.

Each transfer switch enclosure is bolted to a rigid wooden pallet. The pallet is open at two ends for movement by a fork lift. The shipment is secured and further protected with shrink wrap. Do not discard the packing material until the equipment is ready for installation.

A plastic bag of documents will be found within the enclosure, usually attached to the inside of the door. Important documents, such as test reports, wiring diagrams, and appropriate instruction leaflets, are enclosed within the bag and should be filed in a safe place.

### Handling

As previously mentioned, the transfer switch equipment is packaged for fork lift movement. Protect the equipment from impact at all times and DO NOT double stack. Once the equipment is at the installation location and ready for installation, the packaging material can be removed. Once the enclosure is unbolted from the wooden pallet, it can be installed using the lifting provision located on the top of the structure. Be careful not to damage the top or bottom enclosure mounting flanges.

### Storage

Although well packaged, this equipment is not suitable for storage outdoors. The equipment warranty will not be applicable if there is evidence of outdoor storage. If the equipment is to be stored indoors for any period of time, it should be stored with its protective packaging material in place. Protect the equipment at all times from excessive moisture, construction dirt, corrosive conditions, and other contaminants.

It is strongly suggested that the package-protected equipment be stored in a climate controlled environment of -20° to 85°C (-4° to 185° F) with a relative humidity of 80% or less. DO NOT, under any circumstances, stack other equipment on top of a transfer switch equipment enclosure, whether packaged or not.

## Magnum Closed Transition Soft Load Transfer Switches

### General Description

Electrical power generation located at or near the point of its consumption, commonly referred to as **Distributed Generation**, has seen tremendous growth recently due to factors such as limited utility grid generation and transmission capacity combined with the onset of utility deregulation. Strong economic incentives now exist for many users to consider on-site self generation for both improved power reliability and energy cost reduction. Additionally, these opportunities have spurred the development of new and unique types of generating and switching technologies.

Eaton Closed Transition Soft Load Automatic Transfer Switches are just such a technology. Closed transition soft load transfer switches are an ideal solution for power availability, energy management, and generator-set exercising applications. Unlike traditional open transition switches that provide a break-before-make operation, the closed transition soft load switch allows two power sources, usually the utility and a generator set, to be paralleled indefinitely. This permits the load, inductive or resistive, to be gradually and seamlessly transferred from one source to another. All of this is accomplished through the make-before-break operation of the switch with no power interruption to the load.

Eaton Closes Transition Soft Load Switch utilizes an integrated microprocessor based power controller to make active paralleling of two power sources possible. It manages the speed governor and voltage regulator of the generator set to bring the two sources into synchronization. This approach allows the transfer switch to be applied in soft load transfer applications. In addition, it can also be used as a peak shaving switch helping customers to reduce their peak demand charges by paralleling the generator set with the utility source during times of high electrical demand.

Standard fixed drawout or drawout bypass isolation configurations are available with or without an integral service entrance rating. If a switch with a service entrance rating is used as service entrance equipment, the need for separate service disconnects and overcurrent protective devices is eliminated.

Eaton Closed Transition Soft Load Automatic Transfer Switches are available for 800 through 3200 ampere, up to 600 Vac, 50 or 60 Hz applications worldwide. They are offered in both indoor (NEMA 1) and outdoor (NEMA 3R) free standing enclosures utilizing drawout or fixed insulated case Magnum DS switching devices. The Magnum DS switching device is a 100% rated device with a 100 kA interrupting capability at 600 Vac.

### Applications

Power reliability and power costs are two issues of strategic importance in almost all industry segments. Businesses have critical processes that cannot tolerate a shut down, while an extended failure in many cases could cause unrecoverable losses. In addition, significant changes in the utility industry have created on-site generation opportunities for customers to address their power reliability and energy cost concerns. This type of on-site power generation at or near the point of consumption is known as distributed generation. Market studies estimate that over 40% of generation capacity added in the United States alone over the next 10 years will be distributed. A key enabler of these on-site generation systems and reliable power in general is often a closed transition soft load transfer switch.

Typical applications for Eaton Closed Transition Soft Load Automatic Transfer Switches include industrial processes, data centers and critical care facilities. Actually, any location with critical loads where the absence of power could result in lost revenue, production time, or personal injury should make this equipment a prime consideration.

Consider several specific applications:

- A facility with emergency or critical power systems wanting to test their generator sets without a power interruption.
- Any industrial, institutional, or commercial business seeking ways to lower energy costs by reducing demand charges, which can represent over 50% of an electrical bill.
- Energy Service Companies interested in offering performance based solutions to their customer base.
- Electrical power providers interested in offering power reliability solutions to their customer base in return for long term electrical contracts.

The Eaton Closed Transition Soft Load Automatic Transfer Switch can be applied in new installations or as a retrofit to replace an existing open transition transfer switch. A number of application issues should be reviewed. First, since most generator sets run on diesel fuel, there are exhaust emission concerns to consider. In some markets, the Environmental Protection Agency (EPA) limits the number of hours annually that a generator set can be operated. Methods to deal with such restrictions, should they present a problem, are the use of natural gas or dual fuel (natural gas/diesel mixture) types of generator sets. A second issue relates to electrical utility interconnection standards. Many utility companies require multiple levels of protective relaying when a user wishes to parallel to the utility grid. The cost of meeting some of these specifications can be high. These issues should be discussed when peak shaving is being considered.

## Sequence of Operations

### Automatic Mode Operation – Transfer Switch Loss of Normal Power

The system will continuously monitor the condition of the normal power supply. When the voltage or frequency of the normal source is sensed outside the user adjustable set points, and after an adjustable time delay to override momentary dips and/or outages, a contact shall close to initiate a starting of the emergency or stand-by source. Transfer to the alternate source shall take place upon attainment of adjustable pick-up voltage and frequency of the alternate source.

### Return Of Normal Power - Breaker Open Transition Logic Selected

When normal source has been restored and is within the pre-selected ranges for voltage and frequency and after a time delay to ensure the integrity of the normal power source, the load shall be transferred back to normal source in a break-before-make transfer scheme. The generator set will continue to run for a user adjustable time to allow the generator set to run unloaded for cool down, after which the engine will be shut down. Upon completion the system will then be ready for automatic operation.

### Return Of Normal Power - Breaker Closed Transition Logic Selected

When the normal source has been restored and is within the pre-selected ranges for voltage and frequency, and after an adjustable time-delay to ensure the integrity of the normal source, the load shall be transferred back to the normal source in a make-before-brake transfer scheme.

On completion of the time delay, the generator set bus will automatically synchronize with the utility service across the Source 1 (normal) breaker. When the two systems are synchronized, the Source 1 (normal) breaker will close and the Source 2 (emergency) breaker will open. The generator set will continue to run for a user adjustable time to allow the generator set to run unloaded for cool down, after which the engine will be shut down. Upon completion the system will then be ready for automatic operation.

### Return Of Normal - Breaker Interchange (Soft Load) Logic Selected

When the normal source has been restored and is within the pre-selected ranges for voltage and frequency, and after an adjustable time-delay to ensure the integrity of the normal source, the load shall be transferred back to the normal source in a make-before-brake transfer scheme. On completion of the time delay, the generator set bus will automatically synchronize with the utility service across the Source 1 (normal) breaker. When the two systems are synchronized, the Source 1 (normal) breaker will close and the generator set will gradually transfer all loads to the utility.

On completion of the load transfer sequence the Source 2 (emergency) breaker will open. The generator set will continue to run for a user adjustable time to allow the generator set to run unloaded for cool down, after which the engine will be shut down. Upon completion the system will then be ready for automatic operation.

### Peak Shaving

The closed transition soft load transfer switch can be factory configured to automatically parallel to the utility. In this operation mode, the switch will be paralleled with the utility when the user adjustable load power level is exceeded for the predetermined amount of time.

## Test Mode Operation

### Engine Run Test Mode

To perform an engine run test, first place the System Test switch in the "Run" position. Next place the Auto/Test switch in the "Test" position. The engine start contact will close, the engine will start and the generator will produce nominal voltage and frequency. Neither Source 1 nor Source 2 breaker will be operated. Returning either the System Test to "Off" position or Auto/Test switch to "Auto" position will remove the "Engine Start" command. The engine will shut down.

### Transfer Test Mode (Open Transfer)

**Note:** This operation is carried out when the controller's Breaker Logic is programmed for Open Transition via ATC-5000 Input 64.

To perform an open transition test, first place the Test Mode selector switch in the "Mode 1" position, followed by placing the System Test switch in "Test" position followed by placing Auto/Test selector switch in the "Test" position. After an adjustable time delay, the generator will start. After the nominal voltage and frequency are reached, the Source 1 (normal) breaker will open and the Source 2 (emergency) breaker will close on the dead bus. Returning either the Auto/Test selector switch to "Auto" position or the Test Mode selector switch to "Off" position will cause the system to return to normal power as described in "Return Of Normal Power - Breaker Open Transition Logic Selected".

### Transfer Test Mode (Closed Transition)

This operation is carried out when the controller's Breaker Logic is changed to Closed Transfer via ATC-5000 Input 64.

To perform a closed transition test, first place the Test Mode selector switch in the "Mode 2" position, followed by placing the System Test switch in "Test" position followed by placing the Auto/Test selector switch in the "Test" position. After an adjustable time delay, the generator will start. After the nominal voltage and frequency are reached, the generator bus will be synchronized to the utility across the Source 2 (emergency) breaker. When the two sources are synchronized the Source 2 (emergency) breaker closes and then Source 1 (normal) breaker opens.

Returning either the Auto/Test selector switch to "Auto" position or the System Test selector switch to "Off" position will cause the system to return to normal power as described in "Return Of Normal Power - Breaker Closed Transition Logic Selected".

### Transfer Test Mode (Interchange – Soft Load Transition)

This operation is carried out when the controller's Breaker Logic is programmed for Interchange (Soft Load Transition).

To perform an interchange (soft load transition) test, first place the Test Mode selector switch in the "Mode 1" position, followed by placing the System Test switch in "Test" position followed by placing the Auto/Test selector switch in the "Test" position. After an adjustable time delay, the generator will start. After the nominal voltage and frequency are reached, the generator bus will be synchronized to the utility across the Source 2 (emergency) breaker. When the two sources are synchronized the Source 2 (emergency) breaker is closed and the generator gradually assumes all load. On completion of the load transfer sequence the Source 1 (normal) breaker will open.

Returning either the Auto/Test selector switch to "Auto" position or the System Test selector switch to "Off" position will cause the system to return to normal power as described in "Return of Normal Power (Switch in Closed Transition Mode)".

## Magnum Closed Transition Soft Load Transfer Switches

### Paralleling Test mode (Baseload)

This operation is carried out when the controller's Breaker Logic is changed to Parallel via ATC-5000 Input 64 and the Baseload operation is selected.

To perform a paralleling test in a base load mode, first place the Test Mode selector switch in the "Mode 2" position, followed by placing the System Test switch in "Test" position followed by placing the Auto/Test selector switch in the "Test" position. After an adjustable time delay, the generator will start. After the nominal voltage and frequency are reached, the generator bus will be synchronized to the utility across the Source 2 (emergency) breaker. When the two sources are synchronized the Source 2 (emergency) breaker is closed and the generator gradually assumes load up to the user programmable power level and then continuously maintains its power output.

Returning either the Auto/Test selector switch to "Auto" position or the System Test selector switch to "Off" position will cause the generator to gradually unload and then the Source 2 (emergency) breaker will open. The generator set will continue to run for a user adjustable time allowing the generator set to run unloaded for cool down, after which the engine will be shut down. Upon completion the system will then be ready for automatic operation.

### Paralleling Test Mode (Import/Export)

This operation is carried out when the controller's Breaker Logic is changed to Parallel (via ATC-5000 Input 64 and the Import/Export operation is selected).

To perform a paralleling test in Import/Export mode, first place the Test Mode selector switch in the "Mode 2" position, followed by placing the System Test switch in "Test" position followed by placing the Auto/Test selector switch in the "Test" position. After an adjustable time delay, the generator will start. After the nominal voltage and frequency are reached, the generator bus will be synchronized to the utility across the Source 2 (emergency) breaker. When the two sources are synchronized the Source 2 (emergency) breaker is closed and the generator gradually assumes load up to the user programmable import (adjustable power setting for power supplied from the utility) or export (adjustable power setting for power supplied to the utility) power level and then continuously varies its power output to maintain the selected power flow.

Returning either the Auto/Test selector switch to "Auto" position or the System Test selector switch to "Off" position will cause the generator to gradually unload and then the Source 2 (emergency) breaker will open. The generator set will continue to run for a user adjustable time allowing the generator set to run unloaded for cool down, after which the engine will be shut down. Upon completion the system will then be ready for automatic operation.

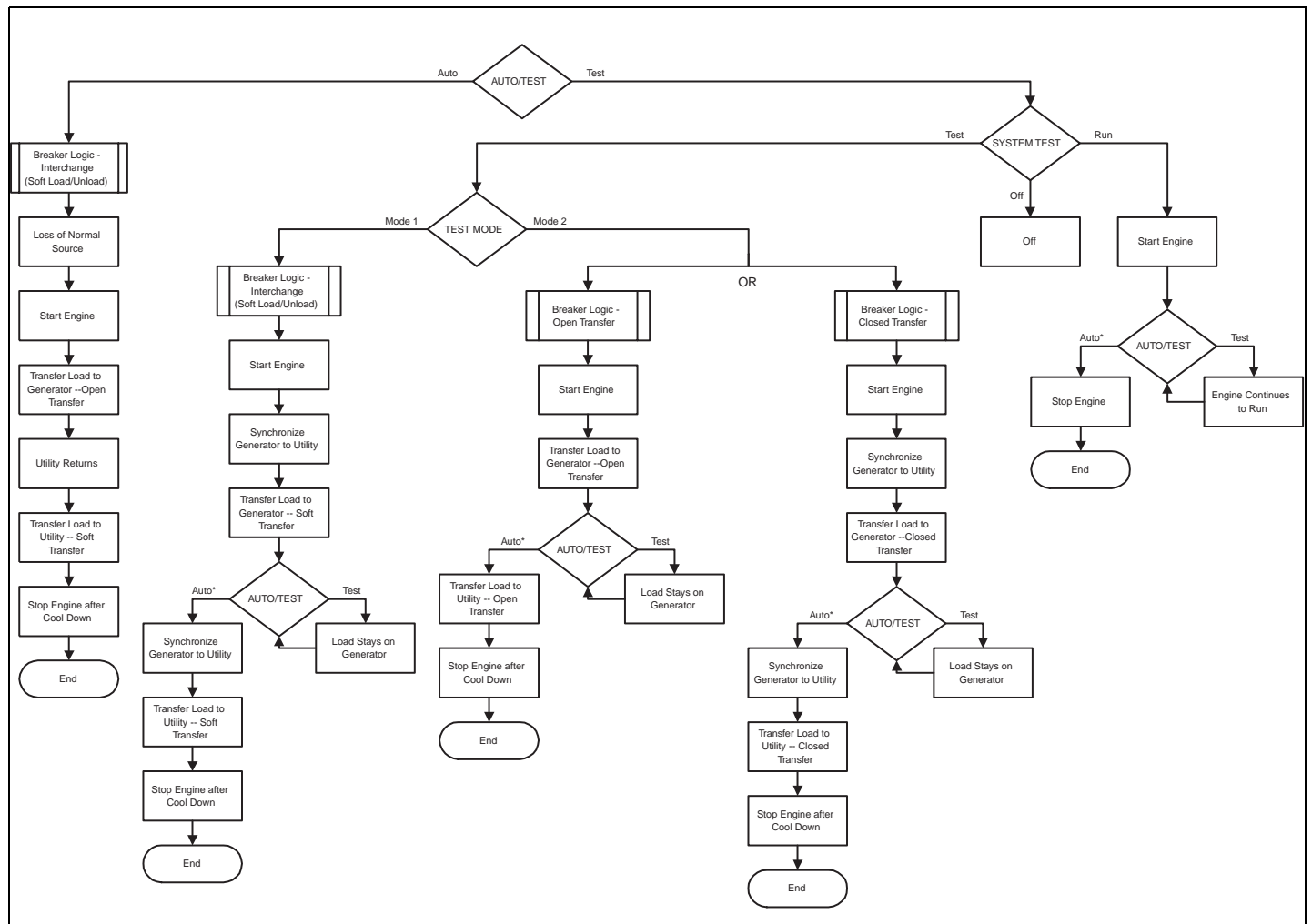

Figure 1. Sequence Flow Chart – Soft Load ATS.

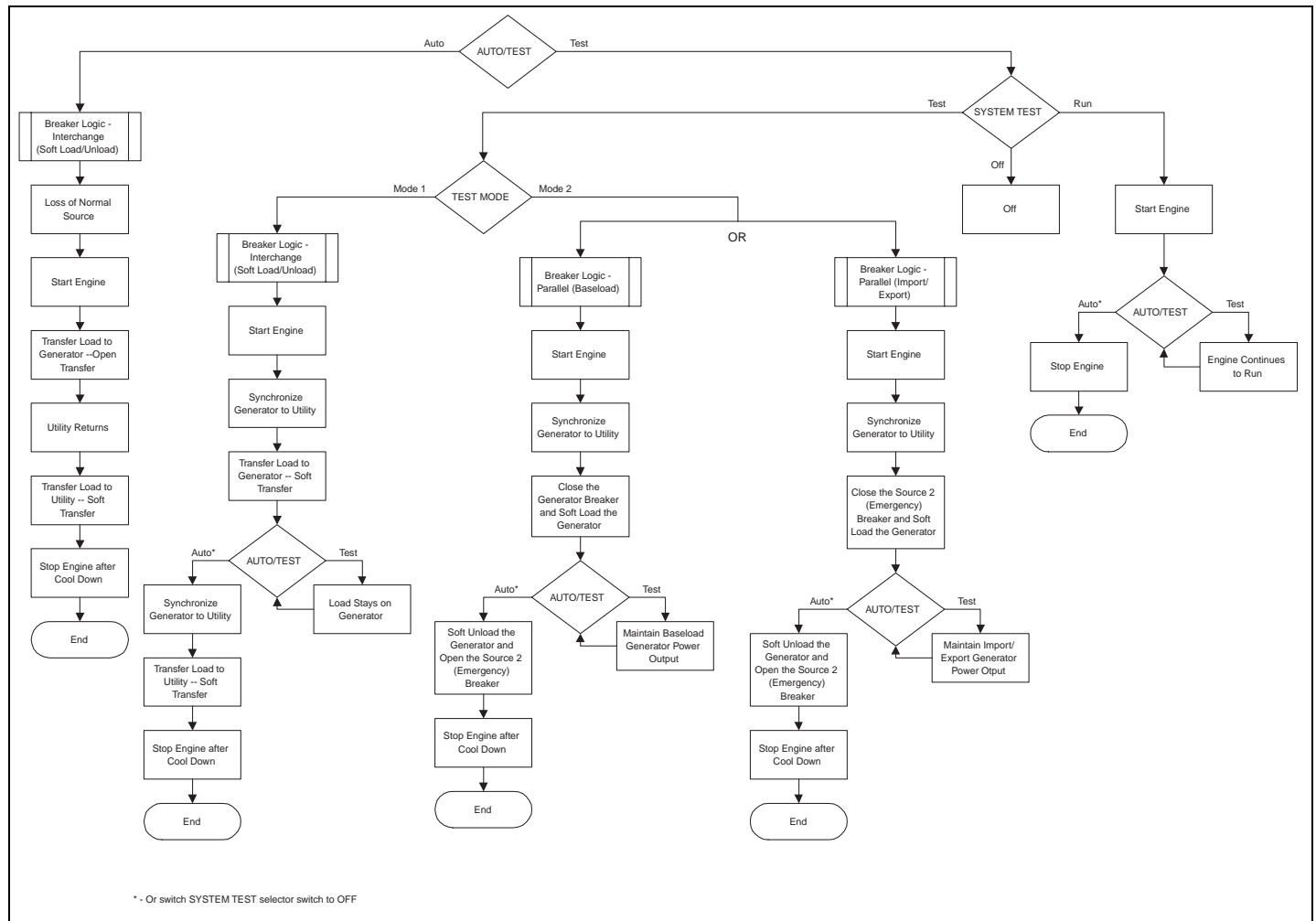

Figure 2. Sequence Flow Chart - Soft Load ATS with Extended Paralleling Capabilities

## Technical Specifications

### System

#### Standards

Eaton Soft Load ATSS are listed in File E38116 by UL, Inc., under Standard UL 1008. This standard covers requirements for ATSS intended for use in ordinary locations to provide for lighting and power as follows:

- a. In emergency systems, in accordance with articles 517 and 700 in the National Electrical Code (NEC), American National Standards Institute/National Fire Protection Association (ANSI/NFPA) 70 and the NFPA No. 76A and/or
- b. In stand-by systems, in accordance with article 702 of the NEC and/or
- c. In legally required stand-by systems in accordance with article 701 of the NEC.

Eaton ATSS are available to meet NFPA 110 for emergency and stand-by power systems, and NFPA 99 for health care facilities when ordered with the appropriate options.

Since Eaton ATSS utilize specially designed switches and/or switching devices as the main power switching contacts, these devices must also be listed under the additional UL Standard 1066. UL utilizes two basic types of listing programs: a) Label Service and b) Re-examination. UL1066 employs a label service list-

ing program which requires an extensive follow-up testing program for listed devices. Standard UL1008 for ATSS lists devices under the re-examination program which only requires a continual physical re-examination of the components used in the product to insure consistency with the originally submitted device. Follow-up testing IS NOT required by UL1008.

Representative production samples of switches and switching devices used in Eaton ATSS are subjected to a complete test program identical to the originally submitted devices on an ongoing periodic basis per UL1066. The frequency of such a re-submittal can be as often as every quarter for a low ampere device.

### Environmental

#### Seismic

With proper installation and by including Option 42 which includes specially designed cleats, the Magnum transfer switch is a Seismic Certified Transfer Switch with certificate for application that is Seismic Zone 4 under the California Building Code, the Uniform Building Code, and BOCA.

#### Operational Conditions

Normal operation in an electrical equipment room for indoor applications. Outdoor applications can subject units to falling rain, freezing temperatures, and 95% humidity (non condensing).

Ambient temperature for operation is between -20 and +65 °C (-4 and 149 °F).

**Table 1. System Ratings**

Standard UL 1008 3-Cycle		30-Cycle Extended Rating
ATS Ampere Rating	Ratings when used with upstream breaker (KA)	Ratings used for coordination with upstream breakers with short time rating
	120 - 600 Vac	120 - 600 Vac
<b>Magnum DS Fixed &amp; Drawout</b>		
800	100	85
1000	100	85
1200	100	85
1600	100	85
2000	100	85
2500	100	85
3200	100	85

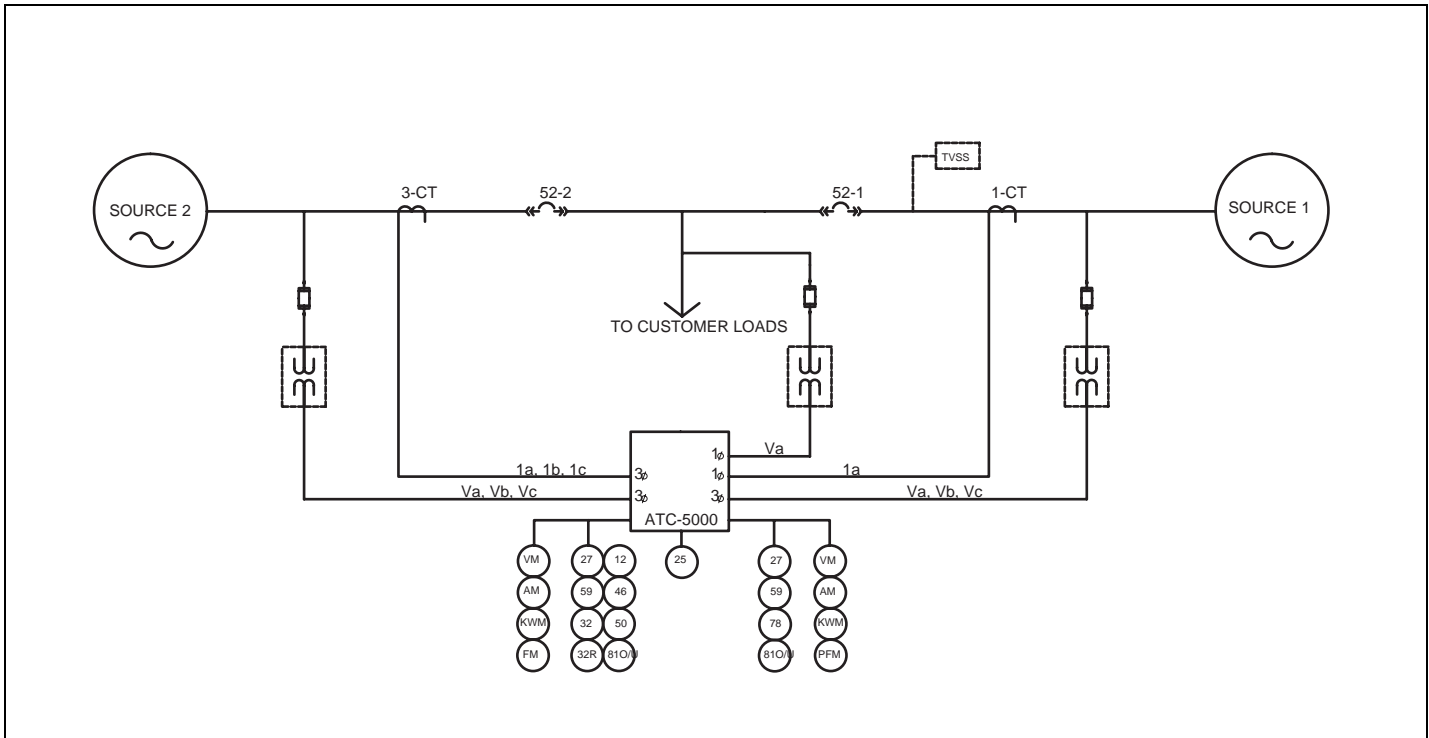

Figure 3. Typical System Diagram – Standard One Line.

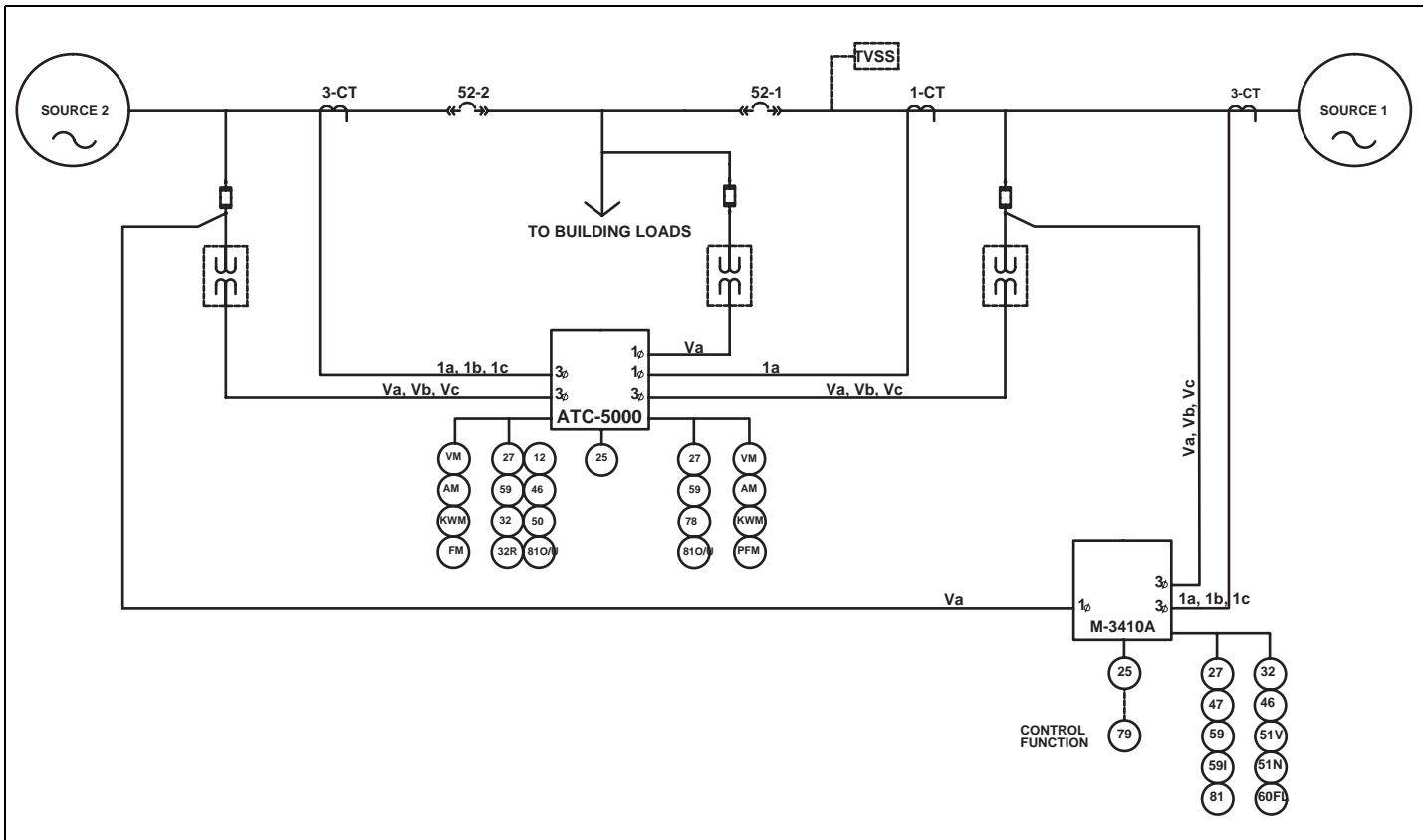

Figure 4. Typical System Diagram – Standard One Line With Utility Grade Multi-function Relaying.

**Base Components**



**Figure 5. Magnum Soft Load ATS Base Components.**

**Enclosure**

The rugged steel switch enclosure is supplied with four door hinges, regardless of enclosure size, to insure proper support of the door and door mounted devices. The hinges have removable hinge pins to facilitate door removal. The doors are supplied as standard with thumbscrew and padlock latches. Cable entry holes are the customer's responsibility.

The door is used to mount a variety of lights, switches, and push buttons, depending upon the options required for a particular switch. All switch doors are supplied with a heavy duty plastic accessory panel in place, whether or not external devices are required. When lights, pushbuttons, or switches are required, they are normally mounted in the plastic door mounted panel.

Transfer switch enclosures and some internal steel mounting plates, such as the transformer panel mounting plate, go through a pre-treatment cleaning system prior to painting to insure a durable finish. Should the enclosure become scratched and in need of touch up paint, use ANSI 61. All remaining steel is galvanized.

The standard switch enclosure is NEMA Type 1 for general indoor use (Table 2).

**Table 4. Dimensions Chart**

Design	Amperes	Poles	Dimensions					
			H (in.)	W (in.)	D(in.)	H (in.)	W (in.)	D (in.)
			NEMA 1			NEMA 3R		
Fixed	800-2000	3&4	90	32	48	90	32	54
	2500-3200	3&4	90	44	48	90	44	54
Drawout	800-2000	3&4	90	32	60	90	32	66
	2500-3200	3&4	90	44	60	90	44	66
Fixed With Bypass Isolation	800-2000	3&4	90	64	48	90	64	54
	2500-3200	3&4	90	88	48	90	88	54
Drawout With Bypass Isolation	800-2000	3&4	90	64	60	90	64	66
	2500-3200	3&4	90	88	60	90	88	66

**Table 2. Transfer Switch Equipment Enclosures**

NEMA TYPE	DESIGN	PROTECTION
1	Indoor	Enclosed Equipment
3R	Outdoor	Rain, Ice Formation

**Power Cables**

Power cables are to be connected to solderless screw type lugs located on the transfer switch switching devices. Refer to the separate Customer Wiring Diagrams supplied with the transfer switch equipment for power termination. Verify that the lugs supplied will accommodate the power cables being used. Also verify that the cables comply with local electrical codes. Standard transfer switch equipment, as supplied from the factory, will accommodate the wire sizes shown in Table 3.

**Table 3. Wire Size for Available Power Cable Connections**

Device	Switch Rating (Amps)	Cables per Phase	Range Wiring Size
Switch	800 - 2000	6	3/0 - 750 MCM
Switch	2500 - 3200	9	3/0 - 750 MCM
Neutral	800 - 2000	24	4/0 - 500 MCM
Neutral	2500 - 3200	36	4/0 - 500 MCM

### Transfer Switch Catalog Number Identification

Transfer switch equipment catalog numbers provide a significant amount of relevant information that pertains to a particular piece of equipment. The catalog number identification table (Table 5) provides the required interpretation information. An example for an open transition switch is offered to initially simplify the process.

**Example:** Catalog Number (circled numbers correspond to position headings in Table 5).

①to② ③ ④ ⑤ to ⑥ ⑦ ⑧ ⑨to⑫ ⑬ ⑭ ⑮  
 CT V C MG E 3 2000 X R U

The catalog number CTVCMGE32000XRU describes a Soft Load ATS with the drawout switching devices mounted vertically in the enclosure. The intelligence, represented by the ATC-5000, is a microprocessor-based logic package. The Magnum Breaker is used as the switching device and is a 3-pole molded case breaker for each source. The continuous current rating of this equipment is 2000 A and is applicable at 480/277 Vac, 60 Hz. The transfer switch equipment is enclosed in a NEMA 3R enclosure and is listed for Underwriters Laboratories (UL).

Table 5. Transfer Switch Catalog Number Explanation.

## Magnum Soft Load Transfer Switches 800-3200 Amperes

### USING THE STYLE IDENTIFICATION GUIDE

The Style Identification Guide provides an overview of the ten basic style/feature categories which generate the 15 digit catalog number.

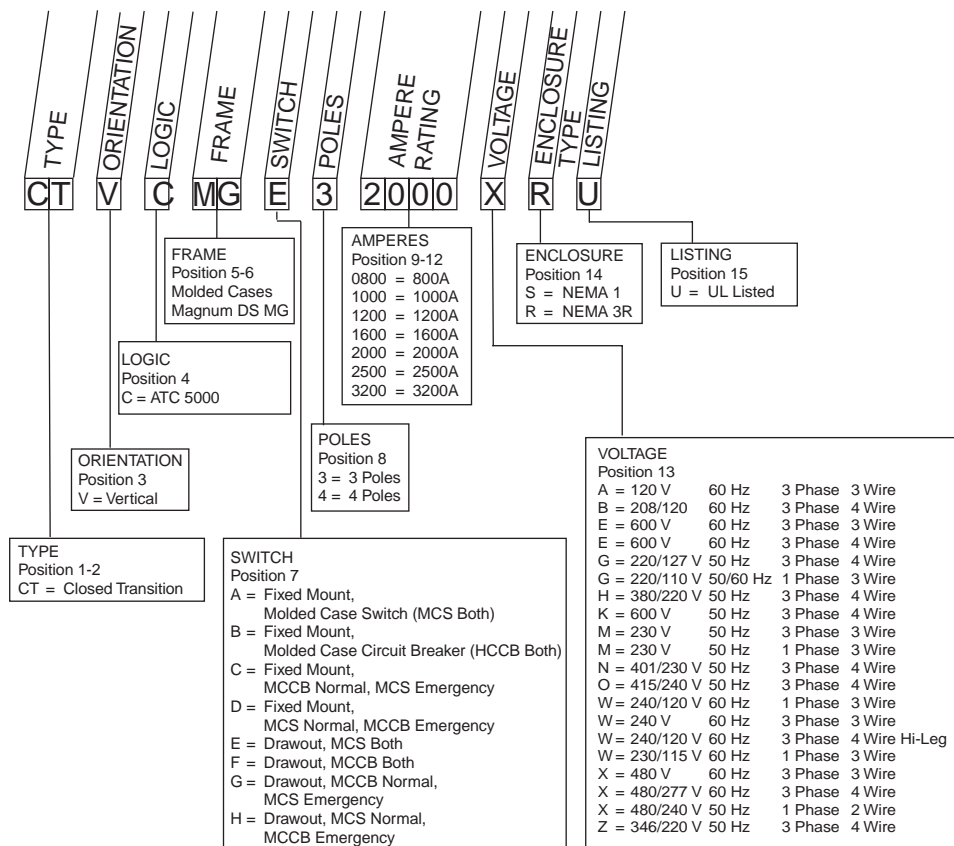

**ATS-5000 Integrated Microprocessor Controller**



The integrated logic controller is a microprocessor-based generator set control and management package. ATC-5000 provides a user-friendly interface allowing operators to easily view system status, view and reset alarms, display metered values and modify device setpoints.

The unit provides fully integrated communication to engine Electronic Control Units (ECUs) including:

- [via CAN bus] standard SAE J1939, Deutz EMR, Scania S6, mtu MDEC;
- [via RS232] Caterpillar CCM to EMCP-II, and ECM.

**Features include:**

- Integrated LED display
- Automatic Transfer Switch Logic
- True RMS sensing
- Frequency and Voltage Bias Outputs for the generator sets
- Protective Relays
  - Device 25A Synchronizer
  - Device 59/27 O/U Voltage for generator set and utility tie
  - Device 81 O/U Frequency for generator set and utility tie
  - Device 78 Phase/Vector shift for the utility tie
  - Device 32/32R Overload/Reverse Power for the generator set
  - Device 46 Load Imbalance for the generator set
  - Device 50/51 Over-current for the generator set
- Load Management
  - Automatic base load/peak shaving
  - Import/Export power control
- Automatic Start/Stop sequencing for gas and diesel engines
- Load dependent start/stop
- Real Power / PF control
- Counters for kWh, engine starts, operating hours and maintenance call
- Freely configurable discrete and analog alarm inputs
- Freely configurable relay and analog outputs
- Language Manager
- Event Logging
- PC and front panel configurable

- Multi level password protection
- Battery voltage monitoring
- CAN bus communication

**Specifications**

Accuracy.....	Class 1
Power supply .....	12/24 Vdc (9.5 to 32 Vdc)
Intrinsic consumption .....	Max. 20 W
Ambient temperature .....	-20 to 70° C
Ambient humidity .....	95 %, non-condensing
<b>Voltage Rated (Vrated):</b> [1] 69/120 Vac or [4] 231/400 Vac	
UL: [1]max.86/150 Vac or [4]max.173/300 Vac	
Setting range(sec.)star: [1]50 to 125 Vac or [4]50 to 480 Vac	
Setting range(sec.)delta: [1]50 to 114 Vac or [4]50 to 380 Vac	
Setting range(prim.):	0.050 to 65,000 kVAc
Measuring frequency.....	50/60 Hz (40 to 70 Hz)
Linear measuring range up to .....	1.3 × Vrated
Input resistance.....	[1] 0.21 MΩ, [4] 0.7 MΩ
Max. power consumption per path.....	< 0.15 W
Current (rated values; Irated) .....	[../1]../1A or [../5]../5A
Current-carrying capacity.....	Igen = 3.0 × Irated I mains = 1.5 × Irated
Load .....	< 0.15 VA
Related short-time current (1s) ...	[../1]50×Irated, [../5] 10 × Irated
<b>Discrete inputs</b> .....	isolated
Input range .....	12/24 Vdc (6 to 32 Vdc)
Input resistance.....	Approx. 6.8 kΩ
<b>Analog inputs</b> .....	Freely scaleable
Type .....	0/4 to 20 mA, Pt100, VDO
Resolution .....	10 Bit
<b>Relay outputs</b> .....	Potential free
Contact material.....	AgCdO
Load (GP) .....	2.00 Aac@250 Vac 2.00 Adc@24 Vdc/0.36 Adc@125 Vdc/0.18 Adc@250 Vdc
Pilot duty (PD).....	B300 1.00 Adc@24 Vdc/0.22 Adc@125 Vdc/0.10 Adc@250 Vdc
<b>Analog outputs</b> .....	Isolated
Type .....	0/4 to 20mA, freely scaleable
Resolution .....	8/12 Bit (depending on model)
Max. load 0/4-20 mA.....	500 Ω
Insulating voltage .....	1,500 Vdc
<b>Housing</b> .....	Type APRANORM DIN 43 700
Dimensions.....	144 × 144 × 118 mm
Front cutout .....	138[+ 1.0] × 138(+ 1.0) mm
Connection .....	Screw/plug terminals depending on connector 1.5 mm <sup>2</sup> or 2.5 mm <sup>2</sup>
Front .....	Insulating surface
<b>Protection system</b> .....	With proper installation
Front.....	IP42 (sealed IP45; gasket kit = P/N 8923-1039)
Back .....	IP21
Weight .....	Depending on version, approx. 1,000g
<b>Disturbance test(CE)</b> .....	Tested according to applicable EN guidelines
<b>Listings</b> .....	UL/cUL listed (voltages up to 300 Vac)

Optional Components

Metering



Figure 6. IQ Analyzer

Highly accurate source or load metering can be provided for advanced energy management and power quality analysis. Meeting the stringent ANSI C12.16 Class 10 accuracy requirement, Eaton IQ Analyzer meter can measure parameters including voltage, current, power (watts, vars and VA), energy, frequency, demand, power factor, %THD (voltage and current), K factor, CBEMA derating factor and crest factor. IQ Analyzer can also communicate with Eaton's industry accepted IMPACC and Power-Net™ Power Management Systems. (See Eaton TD 17530, available on line, for more information.)

Protective Relaying



Figure 7. Protective Relay

For paralleling (including soft loading / unloading) applications, utility grade protective relaying is optional, and offered when utility interconnection standard requires additional protection on top of that provided by ATC-5000 controller. The following protective relays can be included in Eaton Soft Load ATS:

- Beckwith M-3410A - See Appendix B for details.
- Beckwith M-3520
- Schweitzer SEL-351
- Schweitzer SEL-547
- Basler BE1-951
- Basler BE1-IPS100

All above protective relays provide protection necessary to satisfy IEEE P1547 standard "IEEE Standard for Interconnecting Distributed Resources with Electric Power Systems". See Table 6.

Table 6. Protective Relays

ANSI/IEEE Number	Function	ATC-5000	Eaton Digitrip (Optional)	Utility Inertie Protection					
				Beckwith M-3410A (Optional)	Beckwith M-3520 (Optional)	Schweitzer SEL-547 (Optional)	Schweitzer SEL-351 (Optional)	Basler BE1-951 (Optional)	Basler BE1-IPS100 (Optional)
21	Phase Distance				O				
24	Overexcitation V/Hz							S	S
25	Synchronizer	S							
	Synch Check			S	S	S	S	S	S
27	Undervoltage	S <sup>1,2</sup>		S	S	S	S	S	S
27G	Ground Undervoltage			S	O				
32	Reverse/Forward Power	S <sup>1</sup>		S	S	S	S	S	S
40	Loss-of-Field			S					
46	Negative Sequence Overcurrent	S <sup>1</sup>		S	S				
47	Negative Sequence Overvoltage			S	S	S		S	S
50	Instantaneous Phase Overcurrent	S <sup>1</sup>	S <sup>1,2</sup>		S		S	S	S
50N	Instantaneous Ground Overcurrent		O <sup>1,2</sup>		S		S	S	S
51	AC Time Overcurrent	S <sup>1</sup>	S <sup>1,2</sup>				S	S	S
51N	AC Time Ground Overcurrent		O <sup>1,2</sup>	S	S		S	S	S
51V	Voltage Restrained Overcurrent			S	S				S
59	Overvoltage	S <sup>1,2</sup>		S	S	S	S	S	S
59G	Ground Overvoltage			S	O				S
59I	Peak Overvoltage			S	O				
60FL	VT Fuse-Loss Detection			S	S			S	S
62	General Purpose Timers							S	
67	Phase Directional Overcurrent				S		S		S
67N	Residual Directional Overcurrent				O		S		
72	Phase/Vector Shift	S <sup>2</sup>							
79	Reconnect Enable Time Delay			S	S		S		S
81 O/U	Over/Under Frequency	S <sup>1,2</sup>		S	S	S	S	S	S
81R	Rate of Change of Frequency				O				S

1 - Generator Protective Feature    S - Standard Function  
 2 - Utility Protective Feature        O - Optional Function

## Magnum Closed Transition Soft Load Transfer Switches

### Transient Voltage Surge Suppression

Eaton's Clipper Power System -Visor™ series transient voltage surge suppression (TVSS) components can be integrated into any closed transition soft load switch. Surge current ratings 100 kA, 160 kA, and 200 kA per phase provide a range of cost effective facility-wide protection solutions. Status indication on each phase is standard with any TVSS option. Metering and communication capabilities are also available. See Appendix C for details.

### Communications

Optional communication capability via Communication Gateway is available allowing remote data access, control, programming, system interface and dispatch.

### System Interface

A system control panel provides user-friendly interface to the closed transition soft load controller, allowing operators to easily monitor the switching devices position and manually test generator and the system operations.

### Switching Devices Status Lights

- Source 1 Open (Green)
- Source 1 Closed (Red)
- Source 1 Trip (Amber)
- Source 2 Open (Green)
- Source 2 Closed (Red)
- Source 2 Trip (Amber)

### Front Panel Control Switches and Lights

The combination of the following pilot devices can be implemented on the unit:

- AUTO/TEST Switch
- SYSTEM TEST Switch
- TEST MODE Switch
- ALARM SILENCE Switch
- READY FOR OPERATION Lamp (White) - verifies the ATC-5000 status

### Magnum DS Switch Features

UL 489 and UL1008 listed

- 85 – 100 KA standard withstand ratings
- 30-cycle, extended withstand rating
- Five-cycle closing speed
- Electrically and/or manually operated
- True 4 pole switched neutral availability
- Totally enclosed contact assembly
- Fixed mount and DO designs available

### Optional Intergral Overcurrent Protection Capability

For service entrance applications, Digitrip microprocessor-based trip units can be integrated into the power switching devices. This eliminates the need for the separate upstream protective device, saving installation cost and space. Available with various combinations of Long, Short, Instantaneous and Ground Fault Protection, Digitrips can communicate with Eaton's IMPACC and PowerNet™ Power Management Systems.

### Optional On-board 24 Vdc Power Supply

On-board 24 Vdc power supply circuit, consisting of two (2) 12Vdc gel-cell UPS type batteries and battery charger, is available on the unit to provide DC control power to soft load transfer switch components. Engine battery can be connected in the "best battery" circuit as well, further improving the system's reliability.

### Optional Features

#### Service Entrance

When the transfer switch is applied as a service equipment device, the need for separate service disconnects and overcurrent protective devices is eliminated. Refer to the Service Entrance Application illustration.

This optional feature provides the transfer switch as suitable for a service equipment rating. A key operated selector switch permits external power operated service disconnection with a pilot light providing external indication of the disconnect. The option is available with or without ground fault protection. Integral overcurrent protection is provided by means of the power switching device.

#### Installation Comparison

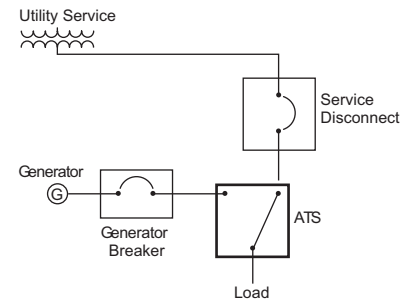

#### Conventional Method...

- UL 1008 Listed ATS
- Separate Generator Breaker
- Separate Generator Breaker Enclosure
- Separate Service Disconnect
- Separate Service Disconnect Enclosure
- Power Cable/Bus Interconnections
- Installation of the Separate Components
- Extra Space Requirement
- Added Maintenance Requirement

#### Cutler-Hammer Method...

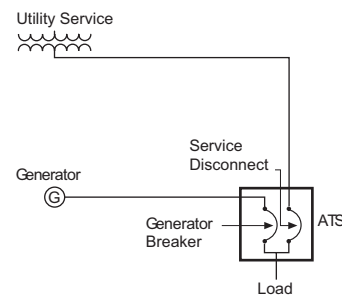

- ATS with Service Equipment Features
- UL 1008 Listed for Service Equipment
- Service Disconnect "both-off" Capability
- Integral Overcurrent Protection
- Lockout (When in disconnect position only)
- Indication of Service Disconnect
- Integrated Design
- Disconnecting Neutral Assembly
- Ground Fault Protection Capability—All Ratings (Required by code on ratings 480V and 1000A or higher)

Table 7. Options

<b>Service Entrance Rating</b>	
16n	Overcurrent Protection - Normal
16e	Overcurrent Protection - Emergency
16b	Overcurrent Protection - Both
37a	Service Entrance
37b	Service Entrance w/ Ground Fault
<b>Metering</b>	
18o	IQ Analyzer - Normal
18p	IQ Analyzer - Emergency
18q	IQ Analyzer - N/E Selectable
18u	IQ Analyzer - Load
<b>Plant Exerciser</b>	
23j	Automatic 24hrs/7days Selectable Load/No Load
<b>Expanded Controller I/O</b>	
25a	Additional Discrete and Analog I/O for Genset Control and Monitoring
<b>Space Heater and Thermostat</b>	
41c	400 W Heater w/Thermostat
<b>Surge Protection</b>	
51m4b	Engine Control (24Vdc) Surge Device
51na1	100kA Surge Device w/AdVisor Source 1
51ns1	100kA Surge Device w/SuperVisor Source 1
51nn1	100kA Surge Device w/NetVisor Source 1
51qa1	160kA Surge Device w/AdVisor Source 1
51qs1	160kA Surge Device w/SuperVisor Source 1
51qn1	160kA Surge Device w/NetVisor Source 1
51sa1	200kA Surge Device w/AdVisor Source 1
51ss1	200kA Surge Device w/SuperVisor Source 1
51sn1	200kA Surge Device w/NetVisor Source 1
<b>On-Board 24 VDC Power Supply</b>	
24c	Battery Charger and Gell-Cell Batteries
<b>Protective Devices</b>	
53a	Beckwith M-3410A
53b	Schweitzer SEL-547
53c	Basler BE1-951
53d	Beckwith M-3520
53e	Schweitzer SEL-351
53f	Basler BE1-IPS100
<b>Communication</b>	
54b	External Communication Gateway
54c	Serial Modbus over Ethernet
<b>Field Start-up</b>	
56a	2-day Start-up (Includes 1 day for travel)

**Appendix A**

**Table A-1. kW to Ampere Conversion Chart**

Three-Phase Ampere Table at Common Line-to-Line Voltage											
kW <sup>①</sup>	200V	208V	220V	230V	240V	380V	400V	415V	460V	480V	600V
5.0	18	17	16	16	15	9	9	9	8	8	6
7.5	27	26	25	24	23	14	13	13	12	11	9
10.0	36	34	33	31	30	19	18	17	16	15	12
15.0	54	52	49	47	45	28	27	26	24	23	18
20.0	72	69	66	63	60	38	36	35	31	30	24
25.0	90	87	82	78	75	47	45	43	39	38	30
30.0	108	104	98	94	90	57	54	52	47	45	36
40.0	144	139	131	126	120	76	72	70	63	60	48
50.0	180	173	164	157	150	95	90	87	78	75	60
60.0	217	208	197	188	180	114	108	104	94	90	72
75.0	271	260	246	235	226	142	135	130	118	113	90
80.0	289	278	262	251	241	152	144	139	126	120	96
100.0	361	347	328	314	301	190	180	174	157	150	120
125.0	451	434	410	392	376	237	226	217	196	188	150
150.0	541	520	492	471	451	285	271	261	235	226	180
175.0	631	607	574	549	526	332	316	304	275	263	210
200.0	722	694	656	628	601	380	361	348	314	301	241
250.0	902	867	820	784	752	475	451	435	392	376	301
300.0	1083	1041	984	941	902	570	541	522	471	451	361
350.0	1263	1214	1148	1098	1052	665	631	609	549	526	421
400.0	1443	1388	1312	1255	1203	760	722	696	628	601	481
500.0	1804	1735	1640	1569	1504	950	902	870	784	752	601
600.0	2165	2082	1968	1883	1804	1140	1083	1043	941	902	722
700.0	2526	2429	2296	2197	2105	1329	1263	1217	1098	1052	842
800.0	2887	2776	2624	2510	2406	1519	1443	1391	1255	1203	962
900.0	3248	3123	2952	2824	2706	1709	1624	1565	1412	1353	1083
1000.0	3609	3470	3280	3138	3007	1899	1804	1739	1569	1503	1203

① At 0.8 Power Factor.

## Appendix B M-3410A Intertie Protective Relay

Refer to the appropriate table to make protective relaying changes  
Table B-1.

### M-3410A Intertie Protective Relay Setpoints

Device Number	Function	Setpoint Ranges	Increment	Accuracy <sup>2</sup>
<b>Sync Check</b>				
25	Phase Angle Window	0° to 90°	1°	± 1°
	Upper Voltage Limit	100.0 to 120.0%*	0.1%	± 0.5 V or ± 0.5%
	Lower Voltage Limit	70.0 to 100.0%*	0.1%	± 0.5 V or ± 0.5%
	Delta Voltage Limit	1.0 to 50.0%*	0.1%	± 0.5 V
	Delta Frequency Limit	0.001 to 0.500 Hz	0.001 Hz	± 0.001 Hz or 5%
	Sync Check Time Delay	1 to 8160 Cycles	1 Cycle	-
	Dead Voltage Limit	0.0 to 50.0%*	0.1%	± 0.5 V or ± 0.5%
Dead Time Delay	1 to 8160 Cycles	1 Cycle	± 2 Cycles	
* Of nominal voltage. Sync Check may be operated as a stand-alone function or supervised by 79 (reconnect). Various combinations of input supervised hot/dead closing schemes may be selected. This function can only be enabled in line-to-line VT configuration and when function 27G and 59G are not enabled.				
<b>Phase Undervoltage</b>				
27	Pickup #1, #2	4 to 100%*	0.1%	± 0.5 V or ± 0.5%
	Time Delay #1, #2	1 to 8160 Cycles	1 Cycle	± 2 Cycles**
* Of nominal voltage. ** When DFT is selected, the time delay accuracy is ± 2 cycles. When RMS is selected, an additional time delay from 0 to + 20 cycles may occur.				
<b>Ground Undervoltage</b>				
27G	Pickup	4 to 100%*	1.0%	± 0.5 V or ± 0.5%
	Time Delay	1 to 8160 Cycles	1 Cycle	± 2 Cycles
* Of nominal voltage, maximum of 600 V. This function can only be enabled when the relay is configured in line-to-line VT and the 25 function is not enabled.				
<b>Directional Power</b>				
32	Pickup #1, #2	-3.00 to + 3.00 PU	0.01 PU	± 0.02 PU or 2%*
	Time Delay #1, #2	1 to 8160 Cycles	1 Cycle	± 2 Cycles
The per-unit pickup is based on nominal VT secondary voltage and nominal CT secondary current settings for currents less than 14 A (2.8 A). This function can be selected as overpower or underpower in the forward direction (positive setting). This function can also be selected for single phase detection for line-to-ground VT. Minimum sensitivity of 100 mA for 5 A CT (real component of current). * Accuracy applies for a nominal current range of 2.5 A to 6 A (5 A CT) or 0.5 A to 1.5 A (1 A CT).				
<b>Loss-of-Field (Dual-Zone Offset-MHO Characteristic)</b>				
40	Circle Diameter #1, #2	0.01 to 3.00	0.01 PU	± 0.01 PU or ± 5%**
	Offset #1, #2	-2.0 to 2.0	0.01 PU	± 0.01 PU or ± 5%**
	Time Delay #1, #2	1 to 8160 Cycles	1 Cycle	± 2 Cycles
	27 Voltage Control (Positive Sequence)	4 to 100%*	0.1%	± 0.5 V or ± 0.5%
	Directional Element	Fixed at -13°	-	-
* Of nominal voltage. ** Accuracy applies for a nominal current range of 2.5 A to 6 A (5 A CT) or 0.5 A to 1.5 A (1 A CT).				

**Magnum Closed Transition Soft Load Transfer Switches**

**M-3410A Intertie Protective Relay Setpoints (Continued)**

Device Number	Function	Setpoint Ranges	Increment	Accuracy <sup>2</sup>
<b>Negative Sequence Overcurrent</b>				
46	Definite Time Pickup	3% to 300%*	1%	± 0.1 A or ± 5%** (± 0.02 A or ± 5%) ± 2 Cycles
		Time Delay	1 to 8160 Cycles	
	Inverse Time Pickup	3% to 100%*	0.1%	± 0.1 A or ± 3%** (± 0.02 A or ± 3%)
		Characteristic Curves	Definite Time / Inverse Time / Very Inverse / Extremely Inverse / IEC / $I_2^2t = K$	
Time Dial Setting	0.5 to 11.0 0.05 to 1.10 (IEC) 1 to 95 ( $I_2^2t = K$ )	0.1 0.01 1	± 3 Cycles or ± 10%**	
	For $I_2^2t = K$ Curve Only			
	Definite Maximum Time to Trip	600 to 65,500 Cycles	1 Cycle	± 3 Cycles or ± 10%
	Reset Time (Linear)	4 Minutes (From Threshold of Trip)	-	-
* Of nominal current for currents less than 14 A (2.8 A). ** Accuracy applies for a nominal current range of 2.5 A to 6 A (5 A CT) or 0.5 A to 1.5 A (1 A CT), and for a pickup of > 5%.				
<b>Negative Sequence Overvoltage</b>				
47	Pickup #1, #2	4 to 100%*	0.1%	± 0.5 V or ± 0.5% ± 2 Cycles
	Time Delay #1, #2	1 to 8160 Cycles	1 Cycle	
* Of nominal voltage.				
<b>Inverse Time Residual Overcurrent</b>				
51N	Pickup	0.50 to 6.00 A (0.10 to 1.20 A)	0.1 A	± 0.1 A or ± 3% (± 0.02 A or ± 3%)
	Characteristic Curves	Definite Time / Inverse Time / Very Inverse / Extremely Inverse / IEC		
	Time Dial Standard Curves #1 - #4 IEC Curves #1 - #4	0.5 to 11.0 0.05 to 1.10	0.1 0.01	± 3 Cycles or ± 10%
<b>Inverse Time Overcurrent, with Voltage Control or Voltage Restraint</b>				
51V	Pickup	0.50 to 12.00 A (0.10 to 2.40 A)	0.01 A	± 0.1 A or ± 3% (± 0.02 A or ± 3%)
	Characteristic Curves	Definite Time / Inverse / Very Inverse / Extremely Inverse / IEC Curves		
	Time Dial	0.5 to 11.0 0.05 to 1.10 (IEC Curves)	0.1 0.01	± 3 Cycles or ± 10%
	Voltage Control (VC) or Voltage Restraint (VR)	4 to 150.0%* Linear Restraint	0.1% -	± 0.5 V or ± 5% -
* Of nominal voltage.				
<b>Phase Overvoltage</b>				
59	Pickup #1, #2	100 to 150%*	0.1%	± 0.5 V or ± 0.5% (± 0.02 A or ± 3%)
	Time Delay	1 to 8160 Cycles	1 Cycle	± 2 Cycles**
	* Of nominal voltage. ** When DFT is selected, the time delay accuracy is ± 2 cycles. When RMS is selected, an additional time delay from 0 to + 20 cycles may occur.			
<b>Ground Overvoltage</b>				
59G	Pickup	4 to 150%*	1.0%	± 0.5 V or ± 0.5% (± 0.02 A or ± 3%)
	Time Delay	1 to 8160 Cycles	1 Cycle	± 2 Cycles
	* Of nominal voltage. This function can only be enabled when the relay is configured in line-to-line VT and the 25 function is not enabled.			

M-3410A Intertie Protective Relay Setpoints (Continued)

Device Number	Function	Setpoint Ranges	Increment	Accuracy <sup>2</sup>
<b>Peak Overvoltage</b>				
59I	Pickup	100 to 150%*	0.1%	± 3%**
	Time Delay	1 to 8160 Cycles	1 Cycle	± 3 Cycles
* Instantaneous voltage magnitude response; intended for ferroresonance protection. ** For fundamental (60 Hz/50 Hz) signal only. For distorted input signals, the accuracy degrades as the order of harmonic signal increases.				
<b>VT Fuse-Loss Detection</b>				
60FL	A VT fuse-loss condition is detected by using the positive and negative sequence components of the voltages and currents. VT fuse-loss output can be initiated from internally generated logic or from input contacts.			
	Time Delay	1 to 8160 Cycles	1 Cycle	± 2 Cycles
<b>Reconnect Enable Time Delay</b>				
79	Time Delay	2 to 65,500 Cycles	1 Cycle	± 2 Cycles
	Reconnect timer starts when all outputs designated as trip outputs reset.			
<b>Over/Under Frequency</b>				
81	Pickup #1, #2, #3, #4	50.00 to 67.00 HZ (40.00 to 57.00 Hz*)	0.01 Hz	± 0.03 Hz
	Time Delay #1, #2, #3, #4	2 to 65,500 Cycles	1 Cycle	± 2 Cycles or ± 0.01%
* This range applies to 50 Hz nominal frequency models. The pickup accuracy applies to 60 Hz models at a range of 57 to 63 Hz, and to 50 Hz models as a range of 47 to 53 Hz. The accuracy is ± 0.15 Hz for a range of 52 to 57 Hz, and 63 to 67 Hz (for 60 Hz nominal) and 42 to 47 Hz and 53 to 57 Hz (for 50 Hz nominal).				
<b>Nominal Settings</b>				
	Nominal Voltage	50 to 500 V*	1 V	-
	Nominal Current	0.50 to 6.00 A	0.01 A	-
	VT Configuration	Line-Line/Line-Ground/Line-Ground-to-Line-Line**		
	Seal-in Delay	2 to 8160 Cycles	1 Cycle	± 1 Cycle or ± 1.0%
	* Maximum measured range for (25), (59), (59G), and (59I) function settings is ≤600 V. ** When line-ground-to-line-line is selected, the relay internally calculates the line-line voltage from the line-ground voltages for all voltage-sensitive functions. When the line-ground-to-line-line selection is applied, the nominal voltage selection should be the line-line nominal voltage (not line-ground nominal voltage).			

**Appendix C: Transit Voltage Surge Suppression Device**

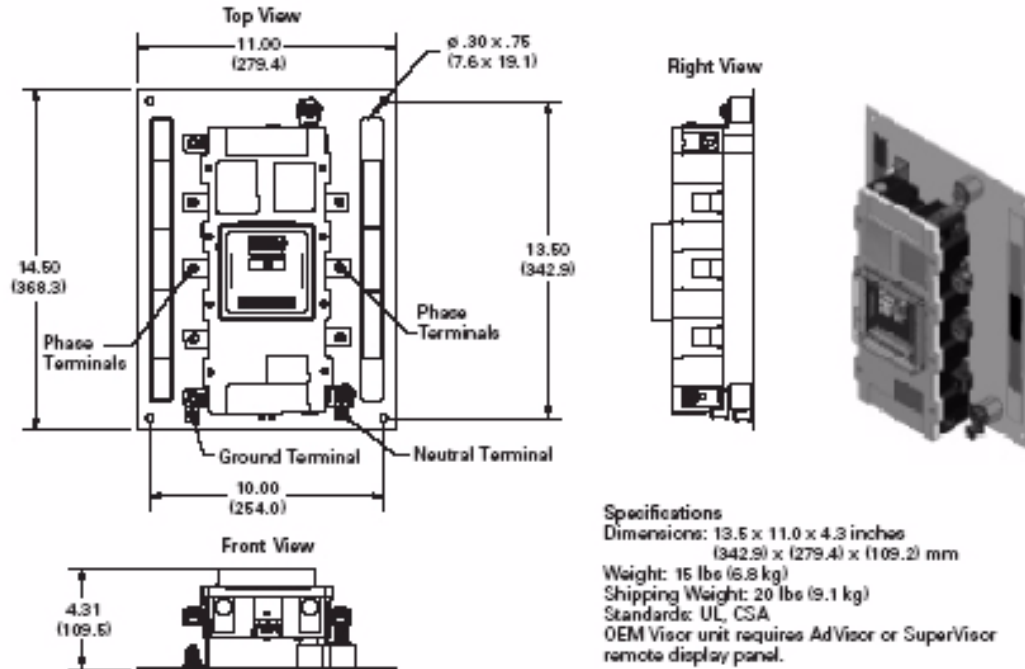

Figure C-1. Visor OEM 100, 100 and 200 kA Technical Data

**Technical Data**

Table C-1. Visor Series — General Parameters

Description	OEM Visor
kA/mode	50 – 250
kA/phase	100 – 500
Split-Phase System	240 L, L, N, G
Wye System Voltages	120/208 277/480 347/600 L, L, L, N, G
Delta System Voltages	240 480 600 L, L, L, G
International System Voltages	127/220Y 230/400 L, L, L, N, G Mexico, other
Monitoring	AdVisor SuperVisor NetVisor
Mounting	Panelboards (PRL1A, 2A, 3A, 4) Remote Monitor Device Panel (Switchboard, Switchgear, Busway) MCC Version
Remote Display Cables <sup>1</sup> Ribbon Cable DB15 600V Class Cable	3 and 6 feet (0.9 and 1.8 m) 8 and 16 feet (2.4 and 4.9 m)
Temperature Storage Operation	-40°C to +60°C -20°C to +60°C
Humidity (Relative)	5 – 95%
Warranty	10 years
Certifications/Listing	UL 1449 2nd Edition, CSA 22.2, UL 1283.

<sup>1</sup> Remote display cables only for use on configuration B and Z models.

**Standards and Certifications**

- All Visor Series units have been tested by UL® and meet the requirements under UL 1449 2nd Edition for surge suppression devices.
- All Visor Series units have been tested as per NEMA® LS-1 and ANSI/IEEE C62.45.
- Category A3 Ringwave (6 kV open circuit, 200A short circuit current at 100 kHz).
- Category B3 Ringwave (6 kV open circuit, 500A short circuit current at 100 kHz).
- Category C1 Combination Wave (6 kV 1.2/50us open circuits, 3 kA 8/20us short circuit current).
- Category C3 Combination Wave (20 kV 1.2/50us open circuits, 10 kA 8/20us short circuit current).
- UL 1020 (standard for safety for thermal cutoffs for use in electrical appliances and components).
- UL 1283 listed for EMI/RFI noise attenuation filtering (50 db at 100 kHz).
- CSA® C22.2.

Monitoring Display Options

Table C-2. Visor Series

Description	AdVisor	SuperVisor	NetVisor

Diagnostics Package

Status Indicator Lights — Red/Green	✓	✓	✓
Form "C" Contacts	✓	✓	✓
Audible Alarm with Reset Button	✓	✓	✓
Transient Counter	✗	✗	✗
Push-to-Test Button	✗	✗	✗
Power Consumption in Watts	0.5 W	1.2 W	3.0 W
Remote Mounting Cables			
Ribbon Cable	✓	✓	✓
DB15 Cable	✓	✓	✓
PQ Meter	✗	✓	✓
Adjustable Set Points	✗	✗	✓
Non-Volatile Memory	✗	✓	✓
Web Enabled	✗	✗	✓
Date Stamped	—	—	✓
Communication Port	✗	✗	✓
Modbus and Ethernet	—	—	✓
Communication Speed (10Base-T)	—	—	✓
Temperature			
Storage	-40°C to +60°C	-40°C to +60°C	-40°C to +60°C
Operating	-40°C to +60°C	-20°C to +60°C	-20°C to +50°C
Humidity (Relative) = 5% – 95%	✓	✓	✓
Remote Mountable Display	✓	✓	✓
Dimensions 4.2-inch W x 4.2-inch H x .4-inch D (106.7 W x 106.7 H x 10.2 D)	✓	✓	✓

Power Quality (PQ) Metering

% Life Remaining	—	—	—
% THD (Voltage)	—	—	—
Event Storage LCD (2 x 16)	—	9999 event	1000 event
Event Capture Sag	—	<b>Counter:</b> • -10% System Voltage • 23 Cycles • Fixed Set Points	<b>Meter:</b> • User Defined Set Points for • Voltage Trigger • 1 Cycle
Swell	—	<b>Counter:</b> • +10% System Voltage • One Cycle • Fixed Set Points	<b>Meter:</b> • User Defined Set Points for • Voltage Trigger • 1 Cycle
Outage	—	<b>Counter:</b> • Zero Voltage • 2 Cycles • Fixed Set Points	<b>Meter:</b> • > 10% System Voltage • 1 Cycle • Fixed Set Points
Surge	—	<b>Counter:</b> • Sensitivity Minimum 10A • 8 x 20 vs. Waveform	<b>Meter:</b> • Sensitivity Minimum 10A • 8 x 20 vs. Waveform
Voltage Meter L – L	—	✓	✓
N – G	—	✗	✓
Accuracy	—	± 5%	± 2%
Resolution	—	8-Bit	8-Bit

<sup>1</sup> Remote display cables only for use on configurations B and Z models.

Note: ✓ = Yes  
✗ = No  
— = Not Applicable

Notes

**Notes**

Notes

Eaton Electrical Inc.  
1000 Cherrington Parkway  
Moon Township, PA 15108-4312  
USA  
tel: 1-800-525-2000  
[www.EatonElectrical.com](http://www.EatonElectrical.com)