

Solar Disconnect Switch



Solar Disconnect Switch

Application Description

Used in Photo Voltaic installations. A DC disconnect switch is required ahead of the inverter to isolate the load from the PV source.

The most common application is a **negative grounded PV system**, with the location of the bond usually found at the inverter (transformer type inverters). Per CEC 14-100 only the current carrying ungrounded conductors shall be switched. Thus in a negative-grounded PV system only the positive conductor is switched. The other conductor of the DC circuit must be grounded (like a neutral in an AC system).

Ungrounded DC floating systems would be applied with transformerless inverters. In an ungrounded DC floating system both positive and negative are switched in the disconnect.

Product Description for Negative Grounded Disconnects

- 30 – 600Ampere, 600Vdc
- Isolated negative ground and equipment ground lug standard
- Factory wired in series for DC, single circuit
- Fusible and Non-Fusible
- Class R fuse clips standard on fusible design
- Heavy Duty K switch design
- Type 3R, 12/3R and 4 painted steel ANSI 61 light grey electrocoat and 4X stainless steel enclosures available

Contents

<i>Description</i>	<i>Page</i>
Selection Guide	2
Product Overview	3
Catalogue Configurator	4
Options and Accessories	5
Technical Data and Specifications	7
Standard Terminal Capacities.	7
Fuse Dimensions.	8
Short Circuit Ratings	10
Flex/Satellite Modifications	12
Air Condition Disconnects	15
General Duty Switches	18
Heavy Duty Switches.	22
Heavy Duty Six-Pole Switches.	32
Heavy Duty Double Throw Switches.	35
Enviroline Switches	41
Heavy Duty Window Switches	44
Heavy Duty Receptacle Switches	48
Heavy Duty Voltage Indicator Switches.	52
Hazardous Location Switches	54
Heavy Duty Quick Connect Switches	56
Solar Switches	60
Product Description, Features, Standards	60
Product Selection	62
Dimensions	63
Zone Blasting Switches.	64
Elevator Control Switches	66
Grounding Switches.	68
Enclosed Motor Disconnects.	70
Pringle Bolted Pressure Switches	78
OEM Operating Mechanisms	85
CSA Enclosure Designations	91

Features

- **“Out of the box solution”**
no additional jumper bars or separate negative ground required
- **Enhanced safety** - fuse is completely de-energized on both line and load side when switch is in off position
- Isolated negative ground terminal included as standard, necessary for grounded PV systems per Section 50 CEC part 1
- Clear polycarbonate dead-front to guard against accidental contact with live parts
- Highly visible line and load warning label specific to PV on door front of switch
- Visibly marked positive and negative terminal connections
- Additional labels included with switch – “PV System Disconnect”

Product Description for Ungrounded DC Disconnects (available Q 4 2011)

- 30A – 600A, 600Vdc
- Factory wired in series for DC, one positive and one negative circuit
- Fusible and Non-Fusible
- Class R fuse clips standard on fusible design
- Heavy Duty K switch design
- Enclosures Type 3R, 12/3R and 4 painted steel ANSI 61 light grey electrocoat & 4X stainless steel
- Highly visible line/load terminal warning labels on door specific to PV
- 100% load break rated
- Compliant with Section 50 CEC part 1 and Section 14-100 CEC Part 1
- CSA certified for use in an ungrounded floating DC system

Features

- **“Out of the box solution”**
no additional jumper bars or separate negative ground required
- Highly visible labeling, specific to PV included with switch - warning labels, ISC short circuit ratings
- Self applied PV system disconnect label included with switch

Product Selection

Non-Fusible 600VDC Disconnect for Negative Grounded PV Systems

System	Ampere	Catalogue Number Type 3R	Catalogue Number Type 12/3R ^②	Catalogue Number Type 4/4X ^③	Lug Capacity Main & Isolated Negative Ground ^④	Equipment Ground Lug	Section 50 CEC Rated Short Circuit Current (ISC) ^⑤
	30	CDH161URKN	CDH161UDKN	CDH161UWKN	#2 - #14 Cu/Al	#4 - #14 Cu/Al	24A
	60	CDH162URKN	CDH162UDKN	CDH162UWKN	#2 - #14 Cu/Al	#4 - #14 Cu/Al	48A
	100	CDH163URKN	CDH163UDKN	CDH163UWKN	1/0 - #14 Cu/Al	#4 - #14 Cu/Al	80A
	200	CDH164URKN	CDH164UDKN	CDH164UWKN	250kcmil - #6 Cu/Al	#2 - #14 Cu/Al	160A
	400	CDH165URKN	CDH165UDKN	CDH165UWKN	(1) 750kcmil - 1/0 or (2) 300kcmil - 1/0 Cu/Al	250kcmil - #6 Cu/Al	320A
	600	CDH166URKN	CDH166UDKN	CDH166UWKN	(1) 750kcmil - 1/0 or (1) 600kcmil - #2 Cu/Al	250kcmil - #6 Cu/Al	480A

Fusible 600VDC Disconnect for Negative Grounded PV Systems

System	Ampere	Catalogue Number Type 3R	Catalogue Number Type 12/3R ^②	Catalogue Number Type 4/4X ^③	Lug Capacity Main & Isolated Negative Ground ^④	Equipment Ground Lug	Section 50 CEC Rated Short Circuit Current (ISC) ^⑤
	30	CDH161NRK	CDH161NDK	CDH161NWK	#2 - #14 Cu/Al	#4 - #14 Cu/Al	19.2A
	60	CDH162NRK	CDH162NDK	CDH162NWK	#2 - #14 Cu/Al	#4 - #14 Cu/Al	38.4A
	100	CDH163NRK	CDH163NDK	CDH163NWK	1/0 - #14 Cu/Al	#4 - #14 Cu/Al	64A
	200	CDH164NRK	CDH164NDK	CDH164NWK	250kcmil - #6 Cu/Al	#2 - #14 Cu/Al	128A
	400	CDH165NRK	CDH165NDK	CDH165NWK	(1) 750kcmil - 1/0 or (2) 300kcmil - 1/0 Cu/Al	250kcmil - #6 Cu/Al	256A
	600	CDH166NRK	CDH166NDK	CDH166NWK	(1) 750kcmil - 1/0 or (1) 600kcmil - #2 Cu/Al	250kcmil - #6 Cu/Al	384A

Non-Fusible 600VDC Disconnect for UNGROUNDED DC Floating Systems ^①

System	Ampere	Catalogue Number Type 3R	Catalogue Number Type 12/3R ^②	Catalogue Number Type 4/4X ^③	Lug Capacity Main & Isolated Negative Ground ^④	Equipment Ground Lug	Section 50 CEC Rated Short Circuit Current (ISC) ^⑤
	30	3HD261NFUDC	12HD261NFUDC	4HD261NFUDC	#2 - #14 Cu/Al	#4 - #14 Cu/Al	24A
	60	3HD262NFUDC	12HD262NFUDC	4HD262NFUDC	#2 - #14 Cu/Al	#4 - #14 Cu/Al	48A
	100	3HD263NFUDC	12HD263NFUDC	4HD263NFUDC	1/0 - #14 Cu/Al	#4 - #14 Cu/Al	80A
	200	3HD264NFUDC	12HD264NFUDC	4HD264NFUDC	250kcmil - #6 Cu/Al	#2 - #14 Cu/Al	160A
	400	3HD265NFUDC	12HD265NFUDC	4HD265NFUDC	(1) 750kcmil - 1/0 or (2) 300kcmil - 1/0 Cu/Al	250kcmil - #6 Cu/Al	320A
	600	3HD266NFUDC	12HD266NFUDC	4HD266NFUDC	(1) 750kcmil - 1/0 or (1) 600kcmil - #2 Cu/Al	250kcmil - #6 Cu/Al	480A

Fusible 600VDC Disconnect for UNGROUNDED DC Floating Systems ^①

System	Ampere	Catalogue Number Type 3R	Catalogue Number Type 12/3R ^②	Catalogue Number Type 4/4X ^③	Lug Capacity Main & Isolated Negative Ground ^④	Equipment Ground Lug	Section 50 CEC Rated Short Circuit Current (ISC) ^⑤
	30	3HD261UDC	12HD261UDC	4HD261UDC	#2 - #14 Cu/Al	#4 - #14 Cu/Al	19.2A
	60	3HD262UDC	12HD262UDC	4HD262UDC	#2 - #14 Cu/Al	#4 - #14 Cu/Al	38.4A
	100	3HD263UDC	12HD263UDC	4HD263UDC	1/0 - #14 Cu/Al	#4 - #14 Cu/Al	64A
	200	3HD264UDC	12HD264UDC	4HD264UDC	250kcmil - #6 Cu/Al	#2 - #14 Cu/Al	128A
	400	3HD265UDC	12HD265UDC	4HD265UDC	(1) 750kcmil - 1/0 or 300kcmil - 1/0 Cu/Al	250kcmil - #6 Cu/Al	256A
	600	3HD266UDC	12HD266UDC	4HD266UDC	(1) 750kcmil - 1/0 and (1) 600kcmil - #2	250kcmil - #6 Cu/Al	384A

Notes

- ① Available Q4 2011
- ② Type 12 enclosures can be field converted to 3R when drain screw removed from end wall of enclosure.
- ③ Enclosure Type 4X stainless steel 30A to 200A, Type 4 painted steel enclosure 400A and 600A.
- ④ Field-wiring conductor size shall be determined by referring to CEC Table 2 and Table 4, or NFPA Table 310.16, 75C column for wire size (AWG). Use wire rated for 90C (194F) or higher.
- ⑤ Per Section 50 CEC Part 1 the ISC is calculated by applying 25% derating factor. Thus a 30A non-fusible disconnect has an ISC rating of 24A. Derating is due to the fact that PV output circuits can deliver output currents higher than the rated short circuit for more than 3 hours near solar noon. Fusible disconnects have two 25% derating factors, one 25% continuous duty derating factor per Section 8-104(5) CEC Part 1 and one solar noon derating factor per Section 50 CEC Part 1.

Note: For Canadian CSA application order "CDH1" switches, for US - UL application order "DH1" switches. (drop C from prefix of catalogue numbers for UL disconnect)

Dimensions

Approximate Dimensions in Inches (mm)

Type 3R Dimensions

Ampere	A	B	C
30 Non-Fusible	16.35 (415)	8.87 (225)	9.89 (251)
30 Fusible	16.35 (415)	8.87 (225)	9.89 (251)
60 Non-Fusible	16.35 (415)	8.87 (225)	9.89 (251)
60 Fusible	16.35 (415)	8.87 (225)	9.89 (251)
100	22.15 (563)	11.84 (301)	9.89 (251)
200	28.27 (718)	16.66 (423)	11.26 (286)
400	45 (1143)	24.12 (613)	12.39 (315)
600	52.5 (1334)	25.12 (638)	14.07 (357)

Type 12/3R and 4/4X Dimensions

Ampere	A	B	C
30 Non-Fusible	14.14 (359)	8.76 (223)	10.22 (260)
30 Fusible	19.8 (485)	8.76 (223)	10.22 (260)
60 Non-Fusible	14.14 (359)	8.76 (223)	10.22 (260)
60 Fusible	19.8 (485)	8.76 (223)	10.22 (260)
100	24.95 (634)	11.79 (299)	10.22 (260)
200	35.38 (899)	16.5 (431)	11.63 (295)
400	57.47 (1460)	24.12 (613)	12.43 (316)
600	63 (1600)	36.34 (923)	14.25 (362)

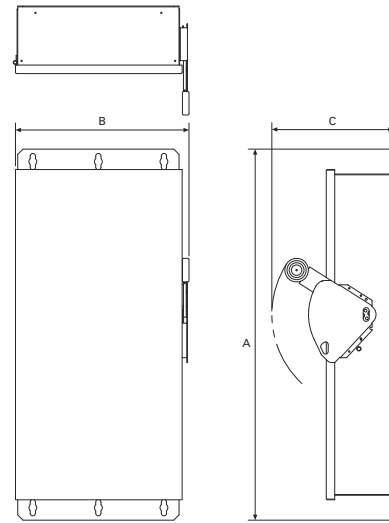
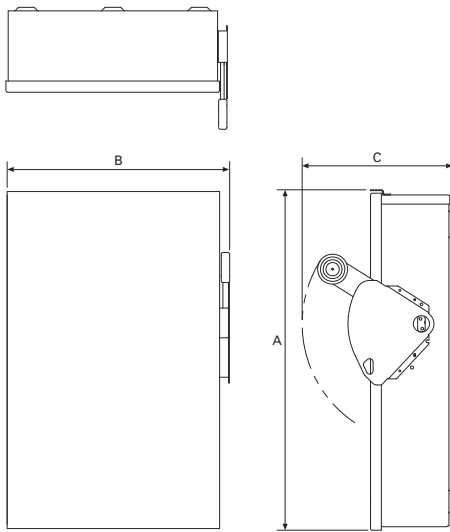

Note: Dimensions apply to disconnects for either negative grounded or ungrounded PV systems.