

August 2007

Sensor Accessories

A Variety of Items for Replacement, Testing or Additional Functionality

Contents

Overview . . . . . 1  
 Model Selection . . . . . 1

Cutler-Hammer® Accessories from Eaton's electrical business include Portable Power Supplies for testing or demonstrating DC sensors, a variety of Replacement Mounting Nuts, Protective End Caps for tubular proximity sensors, and Conduit Adapters for tubular sensors.







DC Sensor Testers / Demonstrators



Replacement Mounting Nuts

And More...

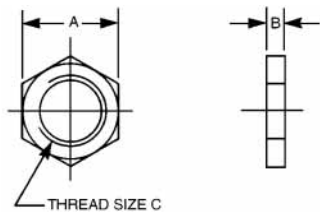





Model Selection — Sensor Accessories

	Description	Sensor Diameter	Catalog Number	Approximate Dimensions in Inches (mm) Except Where Noted																							
	<b>DC Sensor Tester/Demonstrator</b> For 2-, 3- and 4-wire DC sensors Provides 27V DC power from three 9V batteries (included) Test output connections for both NPN and PNP outputs	—	<b>9902A-6501</b>	W x H x D 2.5 x 4.75 x 2.1 inches (65 x 120 x 55 mm)																							
	<b>AC Sensor Tester/Demonstrator</b> For AC sensors Provides AC power from wall mount Includes AC adapter	—	<b>9902A-6502</b>	W x H x D 2.5 x 4.5 x 1.5 inches (65 x 114 x 38 mm)																							
	<b>Replacement Mounting Nuts — Stainless Steel</b> Where Used: Harsh environment for tubular sensors Material of Construction: Stainless Steel Packaging: Two per package	8 mm	<b>E57KNM8</b>																								
		12 mm	<b>E57KNS12</b>																								
		18 mm	<b>E57KNS18</b>																								
		30 mm	<b>E57KNS30</b>																								
	<b>Replacement Mounting Nuts — Brass</b> Where Used: General purpose for tubular sensors. These are the standard mounting nuts shipped with the Comet, Prism and OEM Prism Photoelectric Sensors. Material of Construction: Brass Packaging: Two nuts and two wave washers per package	18 mm	<b>E60KNS18</b>																								
	<b>Replacement Mounting Nuts — Stainless Steel</b> Where Used: Harsh environment for tubular sensors Material of Construction: Stainless Steel Packaging: Two per package	18 mm	<b>E58KNS18</b>	<table border="1"> <thead> <tr> <th rowspan="2">Size</th> <th colspan="3">Dimensions in Inches (mm) Except Where Noted</th> </tr> <tr> <th>A</th> <th>B</th> <th>C</th> </tr> </thead> <tbody> <tr> <td>8 mm</td> <td>0.5 (13)</td> <td>0.16 (4)</td> <td>M8 x 1</td> </tr> <tr> <td>12 mm</td> <td>0.7 (17)</td> <td>0.16 (4)</td> <td>M12 x 1</td> </tr> <tr> <td>18 mm</td> <td>0.94 (24)</td> <td>0.16 (4)</td> <td>M18 x 1</td> </tr> <tr> <td>30 mm</td> <td>1.4 (36)</td> <td>0.16 (4)</td> <td>M30 x 1.5</td> </tr> </tbody> </table>	Size	Dimensions in Inches (mm) Except Where Noted			A	B	C	8 mm	0.5 (13)	0.16 (4)	M8 x 1	12 mm	0.7 (17)	0.16 (4)	M12 x 1	18 mm	0.94 (24)	0.16 (4)	M18 x 1	30 mm	1.4 (36)	0.16 (4)	M30 x 1.5
		Size	Dimensions in Inches (mm) Except Where Noted																								
A	B		C																								
8 mm	0.5 (13)	0.16 (4)	M8 x 1																								
12 mm	0.7 (17)	0.16 (4)	M12 x 1																								
18 mm	0.94 (24)	0.16 (4)	M18 x 1																								
30 mm	1.4 (36)	0.16 (4)	M30 x 1.5																								
30 mm	<b>E58KNS30</b>																										

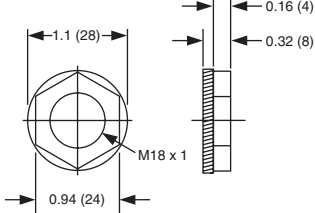
 Stocked product, typical order quantities guaranteed in stock.

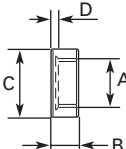
For Customer Service in the U.S. call **1-877-ETN CARE (386-2273)**,  
 in Canada call **1-800-268-3578**.  
 For Application Assistance in the U.S. and Canada  
 call **1-800-426-9184**.

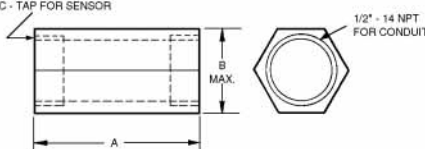
**Model Selection — Sensor Accessories (Continued)**

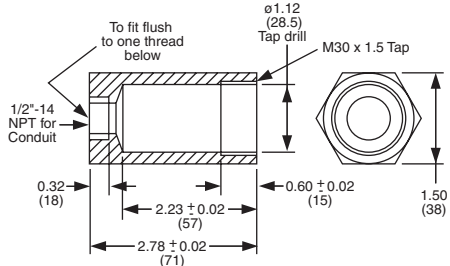
	Description	Sensor Diameter	Catalog Number	Approximate Dimensions in Inches (mm) Except Where Noted																								
	<p><b>Replacement Mounting Nuts — Plastic</b></p> <p>Where Used: Harsh environment for tubular and SM Series sensors</p> <p>Material of Construction: Plastic</p> <p>Packaging: Two per package</p>	18 mm	<b>E57KNC18</b>																									
	<p><b>Protective Caps</b></p> <p>Where Used: Tubular Proximity Sensors</p> <p>Material of Construction: Delrin</p> <p>Packaging: One per package</p>	12 mm	<b>E57KP12</b>	 <table border="1" data-bbox="1136 604 1445 829"> <thead> <tr> <th rowspan="2">Size in mm</th> <th colspan="4">Dimensions in Inches (mm)</th> </tr> <tr> <th>A (Switch Size)</th> <th>B</th> <th>C</th> <th>D (Thickness)</th> </tr> </thead> <tbody> <tr> <td>12</td> <td>0.47 (12)</td> <td>0.39 (10)</td> <td>0.63 (16)</td> <td>0.04 (1.0)</td> </tr> <tr> <td>18</td> <td>0.71 (18)</td> <td>0.36 (9.2)</td> <td>0.83 (21.2)</td> <td>0.04 (0.9)</td> </tr> <tr> <td>30</td> <td>1.18 (30)</td> <td>0.59 (15)</td> <td>1.42 (36)</td> <td>0.07 (1.7)</td> </tr> </tbody> </table>	Size in mm	Dimensions in Inches (mm)				A (Switch Size)	B	C	D (Thickness)	12	0.47 (12)	0.39 (10)	0.63 (16)	0.04 (1.0)	18	0.71 (18)	0.36 (9.2)	0.83 (21.2)	0.04 (0.9)	30	1.18 (30)	0.59 (15)	1.42 (36)	0.07 (1.7)
Size in mm	Dimensions in Inches (mm)																											
	A (Switch Size)	B	C		D (Thickness)																							
12	0.47 (12)	0.39 (10)	0.63 (16)	0.04 (1.0)																								
18	0.71 (18)	0.36 (9.2)	0.83 (21.2)	0.04 (0.9)																								
30	1.18 (30)	0.59 (15)	1.42 (36)	0.07 (1.7)																								
		18 mm	<b>E57KP18</b>																									
		30 mm	<b>E57KP30</b>																									
	<p><b>Conduit Adapters</b></p> <p>Where Used: To attach electrical conduit to rear of tubular sensors</p> <p>Material of Construction: Die cast steel</p> <p>Packaging: One adapter and nut per package</p>	8 mm	<b>E57KC8</b>	 <table border="1" data-bbox="1031 1039 1412 1207"> <thead> <tr> <th rowspan="2">Size</th> <th colspan="3">Dimensions in Inches (mm) Except Where Noted</th> </tr> <tr> <th>A-Length</th> <th>B-Hex</th> <th>C-Tap</th> </tr> </thead> <tbody> <tr> <td>8 mm</td> <td>1.0 (25)</td> <td>1.0 (25)</td> <td>M8 x 1</td> </tr> <tr> <td>12 mm</td> <td>1.5 (38)</td> <td>1.0 (25)</td> <td>M12 x 1</td> </tr> <tr> <td>18 mm</td> <td>1.5 (38)</td> <td>1.0 (25)</td> <td>M18 x 1</td> </tr> <tr> <td>30 mm</td> <td>1.9 (48)</td> <td>1.5 (38)</td> <td>M30 x 1.5</td> </tr> </tbody> </table>	Size	Dimensions in Inches (mm) Except Where Noted			A-Length	B-Hex	C-Tap	8 mm	1.0 (25)	1.0 (25)	M8 x 1	12 mm	1.5 (38)	1.0 (25)	M12 x 1	18 mm	1.5 (38)	1.0 (25)	M18 x 1	30 mm	1.9 (48)	1.5 (38)	M30 x 1.5	
Size	Dimensions in Inches (mm) Except Where Noted																											
	A-Length	B-Hex	C-Tap																									
8 mm	1.0 (25)	1.0 (25)	M8 x 1																									
12 mm	1.5 (38)	1.0 (25)	M12 x 1																									
18 mm	1.5 (38)	1.0 (25)	M18 x 1																									
30 mm	1.9 (48)	1.5 (38)	M30 x 1.5																									
		12 mm	<b>E57KC12</b>																									
		18 mm	<b>E57KC18</b>																									
		30 mm	<b>E57KC30</b>																									
	<p><b>Conduit Adapters</b></p> <p>Where Used: To attach E58 Harsh Duty 30 mm sensors to half-inch conduit fittings</p> <p>Material of Construction: Stainless steel</p> <p>Packaging: One per package</p>	30 mm	<b>E58KC30</b>																									

Stocked product, typical order quantities guaranteed in stock.