

SPD, Power Conditioning, PF Capacitors and Harmonic Filters

Industrial Surge Protection Products



10.1 Introduction	
Industrial and Commercial Surge Protection	2
Datacom Protection	2
Critical Load Protection	2
Telecommunications Protection	3
Power Conditioning	3
10.2 Surge Protective Devices (SPD)	
Product Overview	6
SPD Series for Integration into Electrical Distribution Equipment	8
SPD Series for Mounting External to Electrical Distribution Equipment	12
CVL Surge Protective Device	17
AEGIS Powerline Filters	19
CVX050/100	22
Datacom	25
10.3 Power Conditioning Products	
Sag Ride Through (SRT)	26
Electronic Voltage Regulator (EVR)	32
10.4 Power Factor Correction Capacitors	
Product Overview	34
UNIPUMP	37
UNIPAK	40
AUTOVAR 300 Automatic Power Factor Correction Capacitor Systems	51
AUTOVAR 600 Automatic Power Factor Correction Capacitor Systems	54
AUTOVAR Filter—LV Automatic Harmonic Filter	59
Transient-Free Static Switching Power Factor Correction Units	63
Active-Harmonic Filter-Harmonic Correction Unit—NEMA 1 Enclosure	67

10.1

SPD, Power Conditioning, PF Capacitors and Harmonic Filters

Introduction

Industrial and Commercial Surge Protection



Contents

Description	Page
Telecommunications Protection	3
Power Conditioning	3
Application Description	4
Facility-Wide Power Protection Solutions	5

Industrial and Commercial Surge Protection

- SPD Series for Integration into Electrical Distribution Equipment
- SPD Series for Mounting External to Electrical Distribution Equipment

SPD Series Sidemount Units

Specification grade surge protective devices for installation external to electrical distribution equipment.

SPD Series Integrated Units

Specification grade surge protective devices installed within Eaton's electrical assemblies.

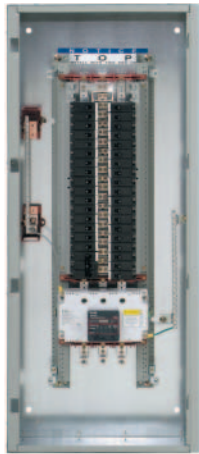

SPD Series Integrated Unit



SPD Series Sidemount Unit

Critical Load Protection

- **AEGIS-HW:** Series filters for up to 20 amperes, single-phase (protection for PLCs, control equipment)
- **AEGIS-VL:** Hardwired surge filter that protects critical loads up to 5 amperes
- **OEM components:** A wide variety of components for domestic/international applications (including military)



AEGIS Products

Datacom Protection

Eaton's line of data and communication surge suppression products are available for nearly any configuration and offer complete protection for computers and small to large networks, including the following:

- Modular protection for multi-pair applications
- Hardwire connected (one or two pair protectors)
- Wiring connectors (D89, DB25 and RJ11)
- Coaxial cable protection
- Mounting hardware



Datacom Products

Telecommunications Protection

Eaton's Telecommunication surge suppression products are designed to safeguard against harmful and potentially disastrous surges and spikes. Our data communication and telecommunication surge suppression solutions protect your equipment from the damage frequently caused by lightning strikes, brownouts, electrical load switching, faulty wiring, downed power lines and more. This unique line was developed to protect against the harmful surges that threaten your telecommunication circuits.



Panelboards with Integrated Surge Protective Devices

- Available in standard and custom configurations
- Ratings:
 - 120/240 Vac, single-phase, three-wire
 - 208Y/120 Vac, three-phase, four-wire
 - 480Y/277 Vac, three-phase, four-wire
 - 600Y/347 Vac, three-phase, four-wire (other voltage configurations are available)
- Copper bus
- 12, 18, 24, 30, 36 and 42 circuits
- Bolt-on branch breakers
- A full range of factory installed modifications and accessories
- Fully rated or series rated

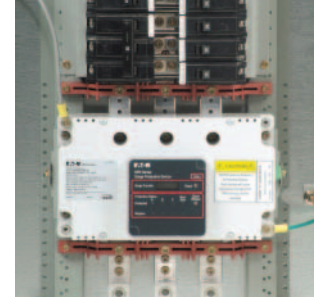

Surge Protective Devices can be Integrated within a variety of Eaton Electrical Assemblies

10

Power Conditioning

Sag Ride Through (SRT)

The sag ride through (SRT) is a power conditioner that corrects voltage sags to maintain uptime and productivity.



Sag Ride Through (SRT)

Electronic Voltage Regulator (EVR)

The electronic voltage regulator (EVR) is designed to meet the needs of customers who experience voltage regulation problems due to brownout conditions from their electric utilities.



Electronic Voltage Regulator (EVR)

Application Description

Application Recommendations for Surge Products

Application Type	Eaton's Surge Product	Features and Competitive Advantages
Light Commercial		
Design build	SPD Series integrated units	Ideal package for any commercial facility
Chain stores	SPD Series sidemount units	Cost-effective, reliable protection using the SPD Series or CVL units
Small facilities	CVL units CVX units	
Large Projects		
Including:	SPD Series integrated units in panelboards, switchboards, MCCs, switchgear, busway and automatic transfer switches	Able to meet competitors' SPD specifications
Commercial	SPD Series sidemount units	Increased surge protection performance by using integrated SPD Series units
Government	CVL units	Wall space savings by using integrated SPD Series units
Schools	Datacom surge protectors	Quick-ship capabilities from Eaton assembly satellites and service centers
Institution	AEGIS units for critical load applications	Power conditioning capability for a wide variety of applications
Military	Power conditioners (EVR and SRT units)	
Industrial		
Including:	SPD Series integrated units in panelboards, switchboards, MCCs, switchgear, busway and automatic transfer switches	Increased surge protection performance by using integrated SPD Series units
Small and large facilities	SPD Series sidemount units	Wall space savings by using integrated SPD Series units
WWTP	CVL units	MCCs with SPD Series units installed protect drives from damage
	AEGIS units for critical load applications such as PLCs, robotics applications, etc.	AEGIS products protect expensive critical loads from harmful damage
	Power conditioners (EVR and SRT units)	EVR units correct voltage regulation problems SRT units correct voltage sag problems
OEM		
Any OEM customer including:	SPD Series integrated units	Years of experience in a variety of OEM applications
Integrators	SPD Series sidemount units	Application assistance and recommendations
Medical equipment	CVL units	Small footprint enables integration in a variety of applications
Automation and control	CVX units Datacom surge protectors AEGIS units for critical load applications	Ability to meet customized requirements
Telecommunications		
Including:	Panelboards and automatic transfer switches with integrated SPD Series units	Ability to meet customized requirements
Cellular sites	SPD Series sidemount units	Application assistance and recommendations
Microwave	CVL units	
PCS	CVX units	
Paging systems		

Facility-Wide Power Protection Solutions

A facility-wide protection approach should be employed to address power quality issues. This approach minimizes overall lifecycle costs and optimizes facility uptime. The following is a

recommended design approach for implementing facility-wide Eaton power protection solutions.

The most accepted design methodology is based on two concepts:

1. Ensure proper grounding conditions exist. All forms of power protection/conditioning rely on good grounding, bonding and earthing practices.
2. Surge protection should be installed at key distribution panels and critical loads.

Application of Surge Protection, Voltage Regulation and Sag Correction Devices

Power Protection & Conditioning Applications



Surge Protection

SPD Series
SPD Series integrated and sidemount surge protective devices.

CVL
CVL sidemount surge protective device.

AEGIS
AEGIS powerline filters provide protection for PLCs and other critical loads.

DATACOM
Datacom family of surge suppressors: For all telephone and data communication lines.

Case Study: Commercial/Industrial Facility

Note: all incoming data, telephone, 4-20 mA, and signal lines require protection.

SA.37.11D.S.E.

10

The above illustration identifies possible locations for:

- Voltage sag correction or regulation solutions (power conditioners)
- ac surge protection
- Telephone, cable and data line surge protection

Eaton offers the most comprehensive and effective facility-wide, power quality solutions.

*Note: these products can be applied either at the service entrance or branch location

SPD Series Sidemount Units



Contents

<i>Description</i>	<i>Page</i>
Surge Protective Devices (SPD)	
SPD Series for Integration into Electrical Distribution Equipment	8
SPD Series for Mounting External to Electrical Distribution Equipment	12
CVL Surge Protective Device	17
AEGIS Powerline Filters	19
CVX050/100	22
Datacom	25



Product Overview

Product Description

Eaton's SPD series surge protective devices are the latest and most advanced UL® 1449 3rd Edition certified surge protectors. Units are available integrated within Eaton electrical assemblies, including panelboards, switchboards, motor control centers, switchgear, automatic transfer switches and bus plugs.



SPD Series Integrated Units

A complete offering of sidemount units designed for mounting external to electrical distribution equipment is also available. Application of SPD Series units throughout a facility will ensure that equipment is protected with the safest and most reliable surge protective devices available. SPD Series units are available in all common voltages and configurations and also in a variety of surge current capacity ratings from 50 through 400 kA. Three feature package options are also available to choose from, ensuring the proper unit is available for a variety of applications.

Features, Benefits and Functions

- Utilizes thermally protected metal oxide varistor (MOV) technology
- Three feature package options
- True protection status indicators report the status of the protection elements, not the status of the applied power
- Available integrated within the following Eaton electrical assemblies: panelboards, switchboards, motor control centers, switchgear, automatic transfer switches and bus plugs
- 10-year warranty

Safety Features

- All units utilize thermally protected metal oxide varistor technology (MOV) as their core surge suppression component. Usage of this technology ensures safe operation when the unit is subjected to abnormal conditions such as temporary overvoltage or high fault current conditions. Under such conditions, the thermally protected MOVs are removed from the circuit quickly and safely before a potentially unsafe condition can occur
- SPD Series units contain no replaceable parts such as surge modules, fuses, or surge counter memory backup batteries. This prevents potential arc flash and shock hazards, as the units require no periodic service or user intervention after installation
- Integrated versions of the unit are factory installed and sidemount versions are factory sealed. These important safety measures further enhance user safety

Three Feature Package Options Available

The SPD Series provides users with the option of selecting between three feature packages. These feature packages are the basic, standard and standard with surge counter. The proper feature package can be selected based on the requirements of the application or specification. A side by side comparison of the individual features found in each package is below.

Basic Feature Package

The basic feature package is perfect for applications where basic, cost-effective, safe and reliable surge protection is required, but budgets don't allow for extra, additional features. Rather than sacrifice performance or safety due to cost, SPD Series units with the basic feature package provide you with high-performing surge protection without sacrificing safety or reliability. The basic feature package provides the same level of surge protection and safety provided by the standard and standard with surge counter feature packages minus some of the features found in them. The package contains dual-colored protection status LEDs that report the true status of the protection in each phase/mode. All four-wire plus ground units also contain an additional set of dual-colored protection status LEDs that report the status of the protection in the neutral/ground mode.

Standard Feature Package

The standard feature package includes all of the features found in the basic feature package, plus an audible alarm with silence button, EMI/RFI filtering, and a form 'C' relay contact that can be used for remote annunciation of the SPD's status. The audible alarm activates and the form 'C' relay contact changes state when any loss of protection is detected or a fault condition exists with the unit. Should such a condition occur, the audible alarm can be silenced by pressing the silence button. The EMI/RFI filter provides up to 50 dB of noise attenuation over the range of 10 kHz through 100 MHz.

Standard with Surge Counter Feature Package

The standard with surge counter feature package includes all of the features found in the standard feature package plus a six-digit surge counter with a reset button. The surge counter indicates the ongoing count of the number of surges the unit has been exposed to and stores them in nonvolatile memory. Should power to the SPD Series unit be completely interrupted, the surge counter will recall and display the surge count prior to the interruption when power is restored. Unlike many surge protectors, the SPD Series' surge counter memory feature does not require a backup battery that would require periodic replacement in order to achieve its memory functionality.

Side-By-Side Comparison of the SPD Series' Available Feature Packages

Feature Package Comparison	Basic	Standard	Standard with Surge Counter
Surge protection using thermally protected MOV technology	■	■	■
Dual-colored protection status indicators for each phase	■	■	■
Dual-colored protection status indicators for the N-G protection mode	■	■	■
Audible alarm with silence button		■	■
Form 'C' relay contact		■	■
EMI/RFI filtering, providing up to 50 dB of noise attenuation from 10 kHz to 100 MHz		■	■
Surge counter with reset button			■

Standards and Certifications

- Integrated versions of the unit are UL 1449 3rd Edition recognized components for the United States and Canada, covered by Underwriters Laboratories certification and follow-up service
- Sidemount versions are UL 1449 3rd Edition listed devices and are also CSA approved



Technical Data and Specifications

- 20 kA nominal discharge current (I_n) rating (maximum rating assigned by UL)
- 50 through 400 kA surge current capacity ratings
- 200 kA short-circuit current rating (SCCR)

SPD Series Unit Integrated within an Eaton Panelboard



10

Contents

Description	Page
Product Overview	6
SPD Series for Integration into Electrical Distribution Equipment	
Standards and Certifications	9
Catalog Number Selection	9
Technical Data and Specifications	10
Dimensions	11
SPD Series for Mounting External to Electrical Distribution Equipment	12
CVL Surge Protective Device	17
AEGIS Powerline Filters	19
CVX050/100	22
Datacom	25

SPD Series for Integration into Electrical Distribution Equipment

Product Description

Eaton's SPD Series surge protective devices are the latest and most advanced UL 1449 3rd Edition certified surge protectors. SPD Series units are available in all common voltages and configurations, and also in a variety of surge current capacity ratings from 50–400 kA.

Application Description

The SPD Series is available as an integrated device within the following Eaton electrical assemblies:

- Panelboards
- Switchboards
- Motor control centers
- Switchgear
- Automatic transfer switches
- Bus plugs

Features, Benefits and Functions

- Uses thermally protected metal oxide varistor (MOV) technology
- Three feature package options
- 10-year warranty

The Integrated SPD Performance Advantage

Installation conductor length is the single most important factor related to an SPD's performance. Performance decreases as the connected conductor length increases. Integrating the SPD within the electrical assembly provides the best possible surge protection by keeping installation conductor lead lengths as short as possible. Integrating the SPD within an electrical assembly can decrease let-through voltages by hundreds of volts, providing you with the best possible surge protection for sensitive electronic loads.

Remote Display Mounting Option Available

The SPD Series offers the option of mounting its display remotely from the device. This is useful for applications where OEMs or other integrators would like to embed the unit within a piece of equipment and still be able to view its display.

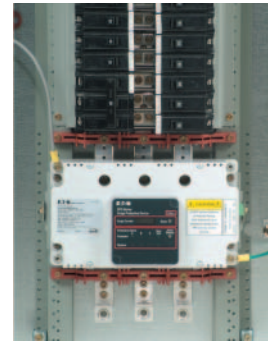

In this installation, the SPD Series is mounted directly to the panelboard's bus bars. This type of installation will provide the best possible surge protection by minimizing the connected lead length.



The SPD Series is also available as an integrated unit interfaced via a circuit breaker resident in the electrical assembly. This installation keeps connected lead lengths short while providing a means of disconnecting power to the unit quickly and easily.

Standards and Certifications

- UL 1449 3rd Edition recognized component for the United States and Canada, covered by Underwriters Laboratories certification and follow-up service
- UL 1283 (Type 2 SPDs only)



Catalog Number Selection

SPD Series Units Mounted Internal to Electrical Distribution Equipment

10

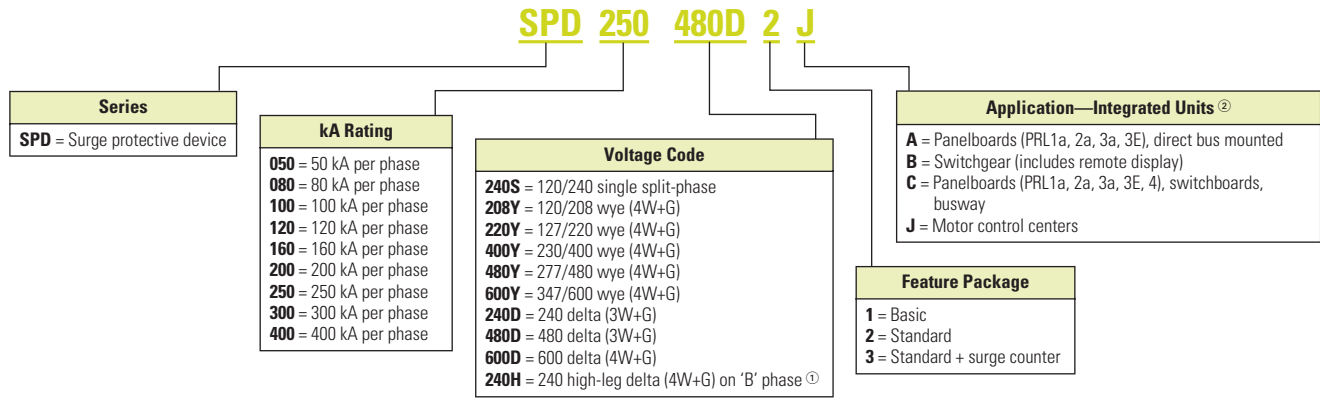

Notes

- ① Please consult the factory for 240 high-leg Delta (4W+G) applications with high leg on 'C' phase.
- ② Units used in PRL1a, 2a, 3a and 3E panelboard applications are available in 50–200 kA ratings only. Use the 'C' option for PRL1a, 2a, 3a and 3E panelboard applications when unit is connected through a circuit breaker.

Example: SPD250480D2J = SPD Series, 250 kA per phase, 480D voltage, standard feature package, motor control center application.

Technical Data and Specifications

SPD Series Specifications

Description	Specification
Surge capacity ratings available	50, 80, 100, 120, 160, 200, 250, 300, 400 kA per phase
Nominal discharge current (I_n)	20 kA (maximum rating assigned by UL)
Short-circuit current rating (SCCR)	200 kA
SPD type	Basic feature package = Type 1 (can also be used in Type 2 applications) Standard and standard with surge counter feature packages = Type 2
Single split-phase voltages available	120/240
Three-phase wye system voltages available	120/208, 127/220, 230/400, 277/480, 347/600
Three-phase delta system voltages available	240, 480, 600
Input power frequency	50/60 Hz
Power consumption (basic units):	
208Y, 220Y, 240S, 240D and 240H voltage codes	0.5W
400Y, 480Y and 480D voltage codes	1.1W
600Y and 600D voltage codes	1.3W
Power consumption (standard and standard with surge counter units):	
208Y, 220Y, 240S, 240D and 240H voltage codes	0.6W
400Y, 480Y and 480D basic voltage codes	1.7W
600Y and 600D voltage codes	2.1W
Protection modes	Single split-phase L-N, L-G, N-G, L-L Three-phase wye L-N, L-G, N-G, L-L Three-phase delta L-G, L-L Three-phase high-leg delta L-N, L-G, N-G, L-L
Maximum continuous operating voltage (MCOV):	
240S, 208Y, 220Y and 240H MCOV	150 L-N, 150 L-G, 150 N-G, 300 L-L
400Y and 480Y MCOV	320 L-N, 320 L-G, 320 N-G, 640 L-L
600Y MCOV	420 L-N, 420 L-G, 420 N-G, 840 L-L
240D MCOV	320 L-G, 320 L-L
480D MCOV	640 L-G, 640 L-L
600D MCOV	840 L-G, 840 L-L
Ports	1
Operating temperature	-40°F through 122°F (-40°C through 50°C)
Operating humidity	5% through 95%, noncondensing
Operating altitude	Up to 16,000 ft (5000m)
Seismic withstand capability	Meets or exceeds the requirements specified in IBC 2006, CBC 2007 and UBC Zone 4
Form C relay contact ratings	150 Vdc or 125 Vac, 1A maximum
Form C relay contact logic	Power ON, normal state—NO contact = open, NC contact = closed Power OFF or fault state—NO contact = closed, NC contact = open
EMI/RFI filtering attenuation	Up to 50 dB from 10 kHz to 100 MHz

Dimensions

Approximate Dimensions in Inches (mm)

50—200 kA Integrated Units

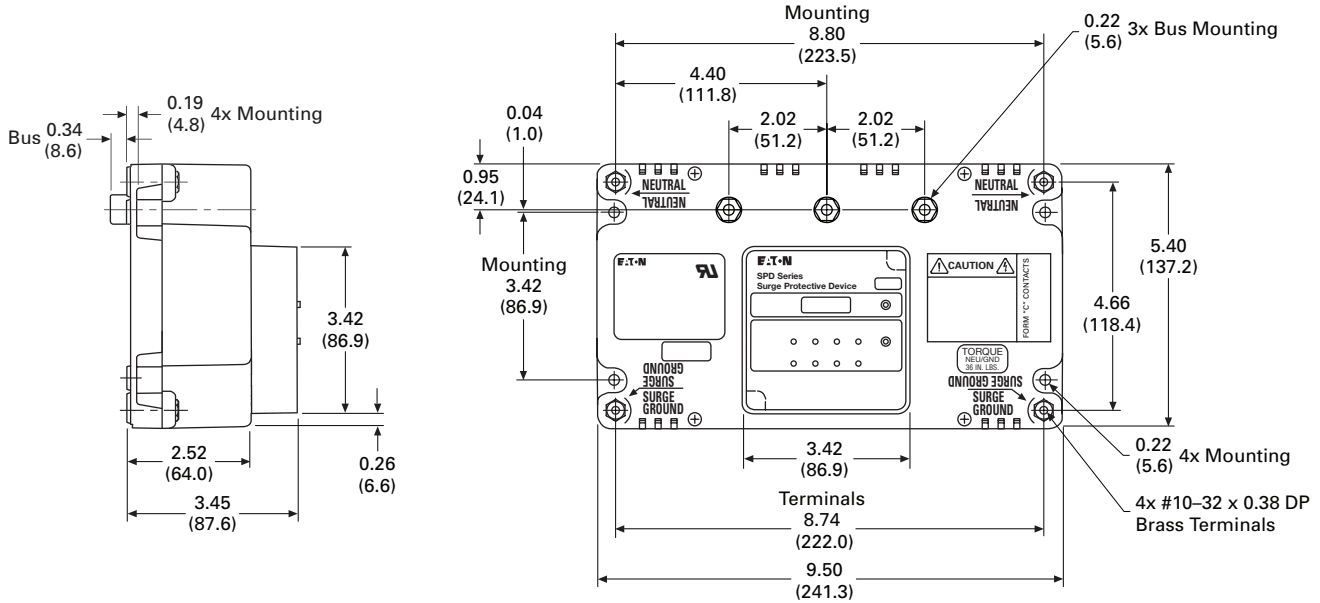

10

250—400 kA Integrated Units

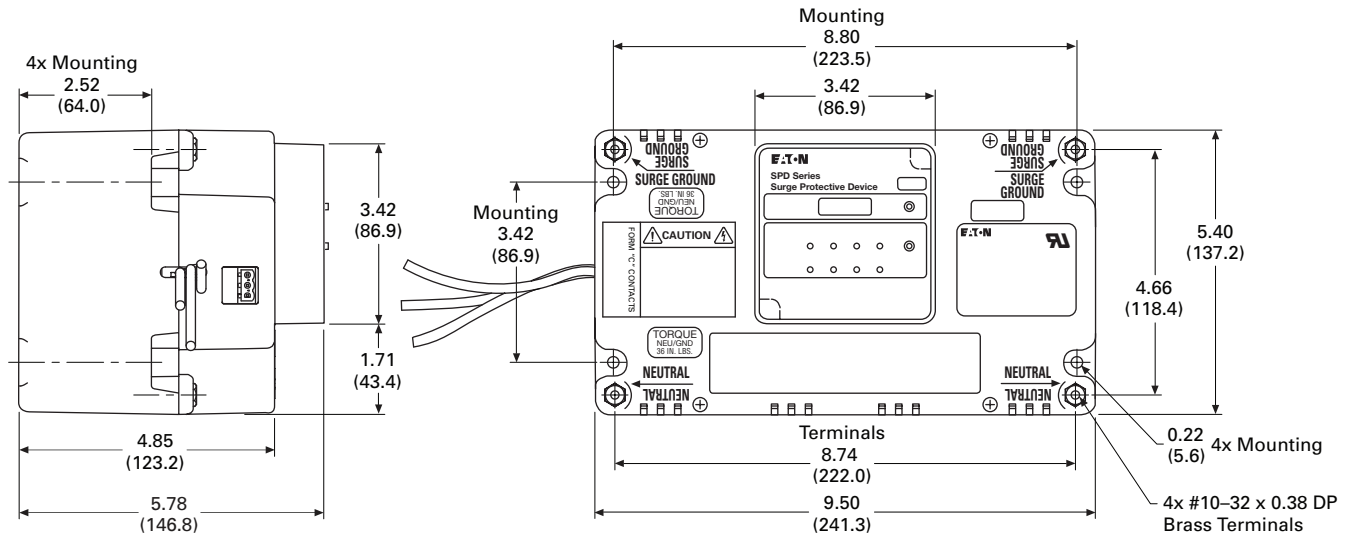

Weights

- 50—200 kA units approximately 3.5 lbs (1.6 kg)
- 250—400 kA units approximately 7.0 lbs (3.2 kg)

Eaton SPD Series Sidemount Unit Mounted Externally to an Eaton Panelboard



10

Contents

<i>Description</i>	<i>Page</i>
Product Overview	6
SPD Series for Integration into Electrical Distribution Equipment	8
SPD Series for Mounting External to Electrical Distribution Equipment	
Catalog Number Selection	13
Technical Data and Specifications	14
Dimensions	15
CVL Surge Protective Device	17
AEGIS Powerline Filters	19
CVX050/100	22
Datacom	25

SPD Series for Mounting External to Electrical Distribution Equipment

Product Description

Eaton's sidemount versions of the SPD Series surge protective devices are the latest and most advanced UL 1449 3rd Edition listed surge protectors. Application of SPD Series units throughout a facility will ensure that equipment is protected with the safest and most reliable surge protective devices available. Units are available in all common voltages and configurations, and also in a variety of surge current capacity ratings from 50 through 400 kA. Three feature package options are also available to choose from.

Features, Benefits and Functions

- Uses thermally protected metal oxide varistor (MOV) technology
- Three feature package options
- 10-year warranty

Standards and Certifications

- UL 1449 3rd Edition listed device
- Canadian Standards Association (CSA)
- UL 1283 (Type 2 SPDs only)



All SPD Series sidemount units come prewired and include a factory-installed conduit interface, making installation very easy.



All SPD Series units are factory sealed, ensuring that the user/installer has no potential of coming into contact with harmful voltages present inside the unit.

Catalog Number Selection

SPD Series Units for Mounting External to Electrical Distribution Equipment

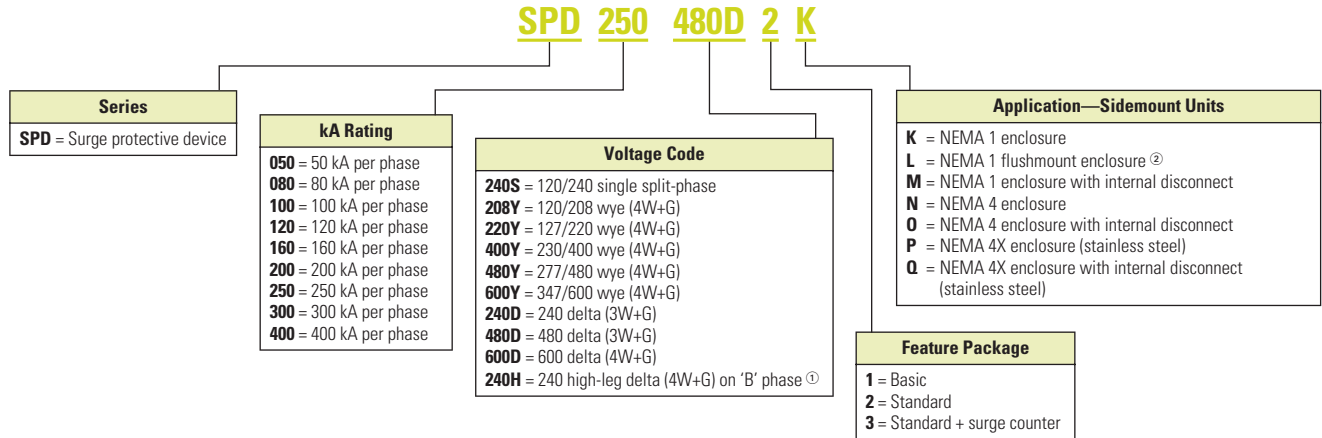

Notes

① Please consult the factory for 240 high-leg delta (4W+G) applications with high leg on 'C' phase.

② NEMA 1 flushmount units are available in 50–200 kA ratings only.

Example: SPD250480D2K = SPD Series, 250 kA per phase, 480D voltage, standard feature package, housed in NEMA 1 enclosure.

Technical Data and Specifications

SPD Series Specifications

Description	Specification								
Surge capacity ratings available	50, 80, 100, 120, 160, 200, 250, 300, 400 kA per phase								
Nominal discharge current (I_n)	20 kA (maximum rating assigned by UL)								
Short-circuit current rating (SCCR)	200 kA								
SPD type	Basic feature package = Type 1 (can also be used in Type 2 applications) Standard and standard with surge counter feature packages = Type 2								
Single split-phase voltages available	120/240								
Three-phase wye system voltages available	120/208, 127/220, 230/400, 277/480, 347/600								
Three-phase delta system voltages available	240, 480, 600								
Input power frequency	50/60 Hz								
Power consumption (basic units):									
208Y, 220Y, 240S, 240D and 240H voltage codes	0.5W								
400Y, 480Y and 480D voltage codes	1.1W								
600Y and 600D voltage codes	1.3W								
Power consumption (standard and standard with surge counter units):									
208Y, 220Y, 240S, 240D and 240H voltage codes	0.6W								
400Y, 480Y and 480D basic voltage codes	1.7W								
600Y and 600D voltage codes	2.1W								
Protection modes	<table border="0"> <tr> <td>Single split-phase</td> <td>L-N, L-G, N-G, L-L</td> </tr> <tr> <td>Three-phase wye</td> <td>L-N, L-G, N-G, L-L</td> </tr> <tr> <td>Three-phase delta</td> <td>L-G, L-L</td> </tr> <tr> <td>Three-phase high-leg delta</td> <td>L-N, L-G, N-G, L-L</td> </tr> </table>	Single split-phase	L-N, L-G, N-G, L-L	Three-phase wye	L-N, L-G, N-G, L-L	Three-phase delta	L-G, L-L	Three-phase high-leg delta	L-N, L-G, N-G, L-L
Single split-phase	L-N, L-G, N-G, L-L								
Three-phase wye	L-N, L-G, N-G, L-L								
Three-phase delta	L-G, L-L								
Three-phase high-leg delta	L-N, L-G, N-G, L-L								
Maximum continuous operating voltage (MCOV):									
240S, 208Y, 220Y and 240H MCOV	150 L-N, 150 L-G, 150 N-G, 300 L-L								
400Y and 480Y MCOV	320 L-N, 320 L-G, 320 N-G, 640 L-L								
600Y MCOV	420 L-N, 420 L-G, 420 N-G, 840 L-L								
240D MCOV	320 L-G, 320 L-L								
480D MCOV	640 L-G, 640 L-L								
600D MCOV	840 L-G, 840 L-L								
Ports	1								
Operating temperature	-40°F to 122°F (-40°C to 50°C)								
Operating humidity	5% through 95%, noncondensing								
Operating altitude	Up to 16,000 ft (5000m)								
Seismic withstand capability	Meets or exceeds the requirements specified in IBC 2006, CBC 2007 and UBC Zone 4								
Enclosure dimensions and weights	Refer to figures on pages 15–16 for enclosure dimensions and weights								
Form C relay contact ratings	150 Vdc or 125 Vac, 1A maximum								
Form C relay contact logic	Power ON, normal state—NO contact = open, NC contact = closed Power OFF or fault state—NO contact = closed, NC contact = open								
EMI/RFI filtering attenuation	Up to 50 dB from 10 kHz to 100 MHz								

Dimensions

Approximate Dimensions in Inches (mm)

50–200 kA Units in a NEMA 1 Rated Enclosure, Weight = 6.8 lbs

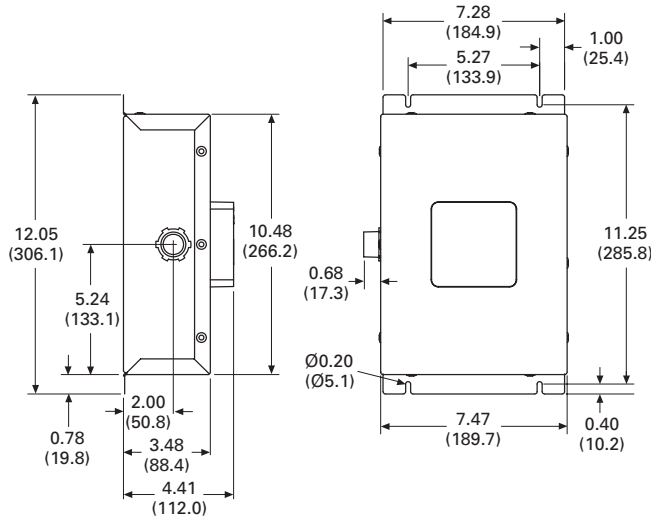

50–200 kA Units in a NEMA 1 Rated Flushmount Enclosure, Weight = 6.8 lbs

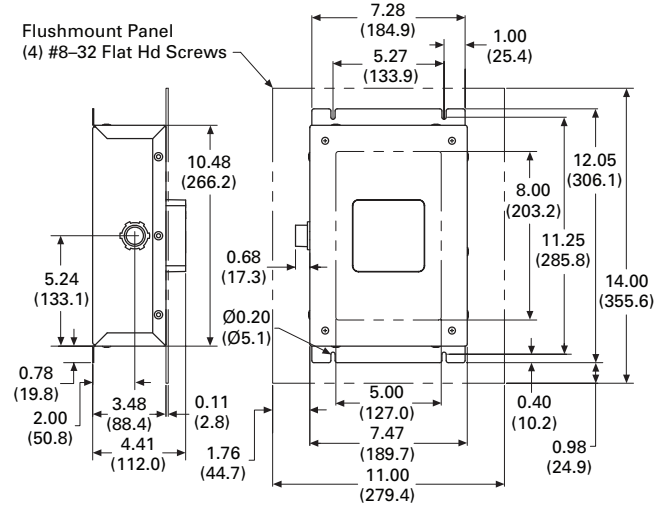

250–400 kA Units in a NEMA 1 Rated Enclosure, Weight = 13.5 lbs

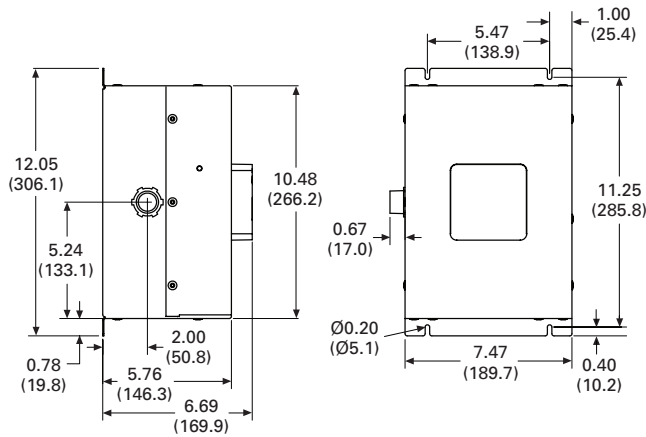

50–400 kA Units in a NEMA 1 Rated Enclosure with Internal Disconnect, Weight = 14.7 lbs

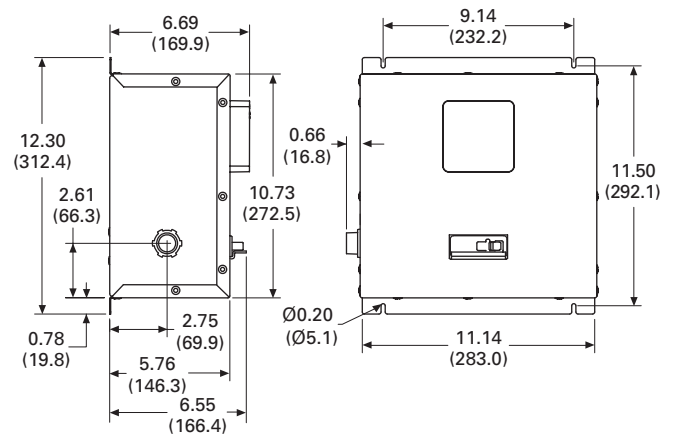

10.2

SPD, Power Conditioning, PF Capacitors and Harmonic Filters

Surge Protective Devices (SPD)

Approximate Dimensions in Inches (mm)

**50–200 kA Units in a NEMA 4 or 4X Rated Enclosure,
Weight = 14.6 lbs**

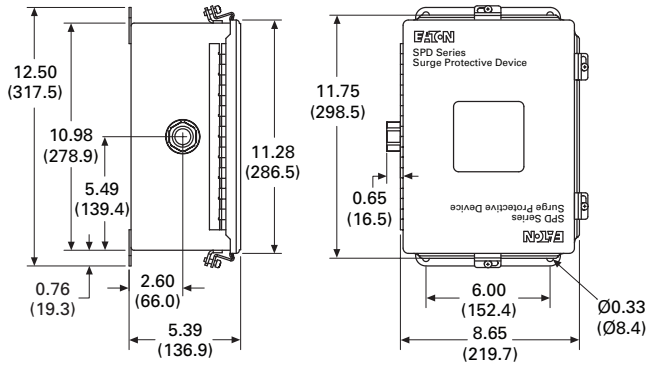

**50–400 kA Units in a NEMA 4 or 4X Rated Enclosure with
Internal Disconnect, Weight = 27.5 lbs**

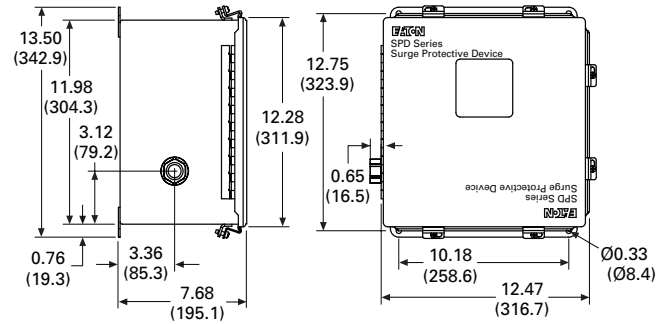

10

**250–400 kA Units in a NEMA 4 or 4X Rated Enclosure,
Weight = 14.6 lbs**

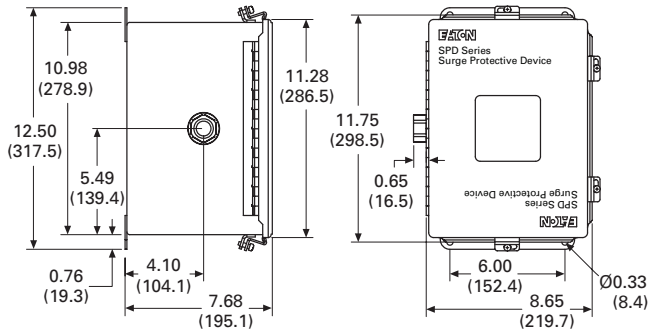

CVL



Contents

<i>Description</i>	<i>Page</i>
Product Overview	6
SPD Series for Integration into Electrical Distribution Equipment	8
SPD Series for Mounting External to Electrical Distribution Equipment	12
CVL Surge Protective Device Catalog Number Selection	18
AEGIS Powerline Filters	19
CVX050/100	22
Datacom	25

CVL Surge Protective Device

Product Description

This surge protection device is used to prevent downtime and equipment damage.

Eaton’s CVL is a commercial grade and light industrial surge protective device (SPD) that combines surge suppression components and EMI/RFI filtering to provide effective protection for sensitive electronic loads.

Features, Benefits and Functions

- SurgePlane™ technology to ensure reliability and performance by using a low impedance copper platform
- Compact design to enable close mounting to electrical distribution equipment
- Parallel hybrid filter technology
- Individually fused surge suppression components
- Status indicator lights to monitor supply power, surge suppression component status and fusing
- Can be remotely monitored using Form C contacts
- Audible alarm
- Ideal for OEM panel applications
- Proven track record in international applications

Standards and Certifications

- UL 1449 listed, UL 1283 listed, CSA approved
- The UL 1283 listed filter protects against ringing transients and EMI/RFI noise disturbances. The tuned suppression filter achieves 40 dB attenuation at 100 kHz



10.2

SPD, Power Conditioning, PF Capacitors and Harmonic Filters

Surge Protective Devices (SPD)

Catalog Number Selection

CVL

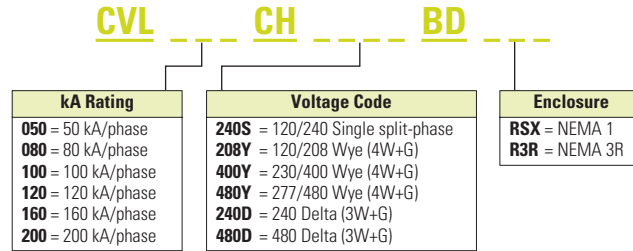

AEGIS Solutions



Contents

Description	Page
Product Overview	6
SPD Series for Integration into Electrical Distribution Equipment	8
SPD Series for Mounting External to Electrical Distribution Equipment	12
CVL Surge Protective Device	17
AEGIS Powerline Filters	
Standards and Certifications	20
Catalog Number Selection	21
Technical Data and Specifications	21
CVX050/100	22
Datacom	25

AEGIS Powerline Filters

Product Description

Eaton’s AEGIS solutions are specifically designed to protect expensive electronics from the hazards that exist within a facility. This critical load protection is effective at reducing harmful surges and noise. Applying this high performance series powerline filter at your critical loads results in “clean” power entering the electronics and reduction of “soft” errors, operational malfunction and damage to components.

Application Description

The AEGIS is the ideal protection solution for your critical loads and facilities.

Loads

- Programmable controllers (PLCs)
- Scanning devices
- ATMs (Automatic Teller Machines)
- Cash registers
- Alarm systems
- Microprocessor-controlled OEM products
- Robotics
- CAD/CAM systems
- Control equipment
- Medical electronics and devices

Why Should Sensitive Electronic Loads be Protected?

PLC manufacturers and service technicians recommend the use of surge suppressors and filters to prevent downtime and equipment damage due to surges and electrical line noise. One study shows failure to protect sensitive electronic loads costs American manufacturing, commercial and service industries over \$39 billion per year in lost time and revenue. Preventing these losses is a major cost-saving opportunity.

Features, Benefits and Functions

AEGIS powerline filters protect against the full spectrum of transient disturbances.

AEGIS filters the entire sine wave and is effective against both frequently occurring low energy and occasional high energy transients. High energy transients can create immediate damage, while low energy transients cause microprocessor failure over time.



**AEGIS VL Hardwired Critical Load Filter
1, 3 and 5 Ampere Modules Only**



**Hardwired Surge Filter that
Protects Critical Loads (3, 5, 10,
15 or 20 Ampere Models)**

10.2

SPD, Power Conditioning, PF Capacitors and Harmonic Filters

Surge Protective Devices (SPD)

AEGIS Powerline Filters

Features	Benefits
Unique series hybrid design (AEGIS-HW)	Protection against high and low energy transients and noise. The tracking filter reacts instantly to changes in frequency and voltage, regardless of phase angle, magnitude or polarity. Active at all times, providing more protection than a conventional surge suppressor. Extends the life of your microprocessors by eliminating degrading power disturbances.
High performance suppression capabilities (AEGIS-HW)	AEGIS-HW and AEGIS-PR have up to 45,500 amperes of surge current suppression and 75 dB of noise attenuation at 100 kHz. This guarantees a superior level of protection and reliability.
Status monitoring lights (AEGIS-HW)	No more testing or guessing whether your unit is working properly. Filter indicator lights expedite your troubleshooting efforts during downtime situations.
5-year downstream equipment warranty (AEGIS-HW only)	Eaton provides a 5-year extended warranty on the microprocessor power supply protected by AEGIS. No other manufacturer offers this level of assurance in backing up its claim of product performance, quality and reliability.
Value (AEGIS-HW)	AEGIS provides superior value when considering the level of performance and benefits offered. It truly delivers the best “bang” for your dollar.
Optional remote monitoring capabilities (AEGIS-HW, AEGIS VL only)	Observe all your operations on a remote basis, including the power protection devices used to safeguard your critical and sensitive electronic loads.
DIN rail, J-rail or flange mounting connections (AEGIS-HW only)	The DIN rail mountable enclosures greatly reduce installation time, effort and cost. This unique container is the preferred choice among OEMs and contractors.
Thermal cut-off protection (TCO) (AEGIS-HW only)	Thermal fuse improves indication, monitor and control during fault conditions.

10

AEGIS Hybrid Series Powerline Filters

Three-Wire Design has Normal and Common Mode Protection (L-N, L-G, N-G)

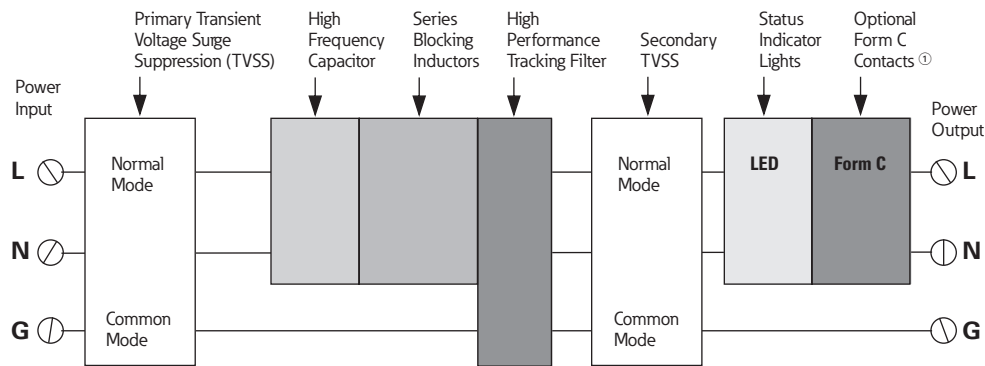

Standards and Certifications

- UL 1283
- CSA



Note

① Option for AEGIS.

Catalog Number Selection

AEGIS-HW

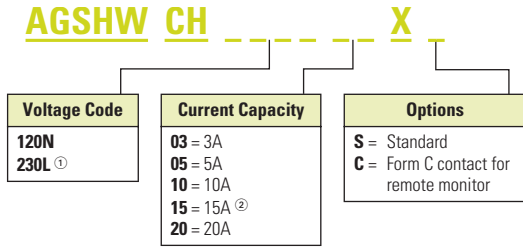

AEGIS-VL

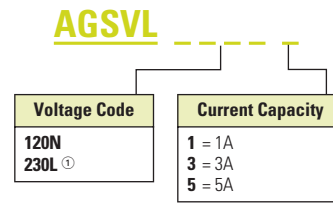

Technical Data and Specifications

Specifications

Application	AEGIS-HW 2 W&G Grounded Systems	AEGIS-VL 2 W&G Grounded Systems
Input voltage single-phase	120, 220, 240 Vac, single-phase	120, 220, 240 Vac, single-phase
Amperage	3, 5, 10, 15, 20 amperes	1, 3, 5 amperes
Frequency	50/60 Hz	50/60 Hz
Protection modes	L-N, L-G, N-G	L-N, L-G, N-G
MCOV	150, 320 volts	150, 320 volts
Noise attenuation		
Normal mode:	75 dB at 100 kHz	75 dB at 100 kHz
Common mode:	50 dB at 5 MHz	50 dB at 5 MHz
Filter bandwidth	10 kHz to 100 MHz	10 kHz to 100 MHz
Total peak surge current	45.5 kA per phase	39 kA per phase
Operating temperature	-40°F to +122°F (-40°C to +50°C)	-40°F to +122°F (-40°C to +50°C)
Response time	Less than 1 nanosecond	Less than 1 nanosecond
Options	Form C relay contacts	N/A

10

IEEE C62.41 (2002) Test Waveforms for AEGIS-HW and VL Versions

Category A Ringwave (Line-to-Neutral) (6000V, 200A)

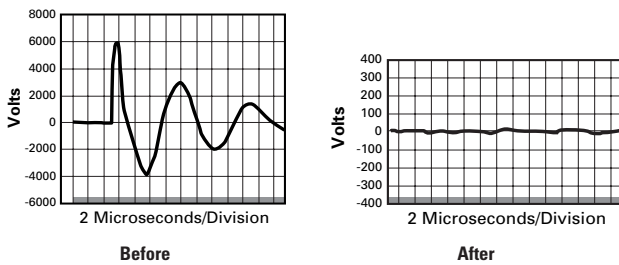

Category B Combination (Impulse) Wave (6000V, 3000A)

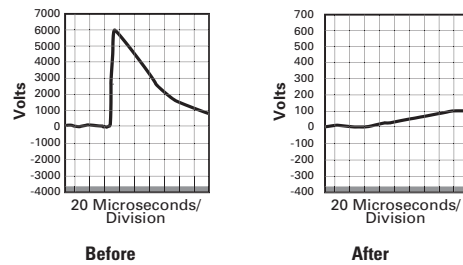

Let-Through Voltages (L-N) ③

Description	AEGIS-HW (L-N Mode)
Category A ringwave (600V, 200A)	6V ④
Category B ringwave (600V, 500A)	9.6V ④
Category B combination (impulse) wave (6000V, 300A)	70V ④ (206V, dynamic at 90°)

Notes

- ① 230V applies to 220 and 240 volt applications.
- ② Model rated at 15 amperes UL/CSA = 16 amperes CE.
- ③ Based on ANSI/IEEE C62.41, 1991 and C62.45, 1992.
- ④ Static testing.

CVX050/100A



Contents

Description	Page
Product Overview	6
SPD Series for Integration into Electrical Distribution Equipment	8
SPD Series for Mounting External to Electrical Distribution Equipment	12
CVL Surge Protective Device	17
AEGIS Powerline Filters	19
CVX050/100	
Catalog Number Selection	23
Technical Data and Specifications	23
Dimensions	24
Datcom	25

CVX050/100

Product Description

With over two decades of experience in the surge suppression industry and extensive R&D initiatives, Eaton is considered a world leader in surge protective device (SPD) manufacturing. All of Eaton's products are manufactured in an ISO® 9001:2000 and ISO 14001 certified facility.

Eaton's CVX050/100 models are rugged, cost-effective, high-quality SPDs that feature thermally protected MOVs that eliminate the failure characteristics of standard Metal-Oxide-Varistors. The TPMOV is a fail-safe device that monitors the status of the metal-oxide disk and connects itself from the power system when the disk is approaching breakdown.

The CVX050/100 is easy to install adjacent or even internal to electrical equipment. When installing an SPD in a retrofit environment, it is important to mount the device as close to the electrical equipment as possible. Keep the wiring (lead length) between the electrical equipment and SPD as short as possible, and twist or wire tie the conductors together to reduce the wire's impedance factor.

Application Description

Eaton's CVX050 and CVX100 SPDs protect electronic equipment from damaging transients. These units are suitable for medium and low exposure level applications that require cost-effective, high quality system protection including:

- Residential/small business
- Light industrial
- Light commercial
- Branch panel protection

Features, Benefits and Functions

- Advanced surge path technology for high fault current capacity, low impedance, high frequency design
- Rugged NEMA® 4X (IP65) enclosure
- Large diameter, thermally protected metal oxide varistors provide long life and fail-safe operation
- LED monitoring of each phase
- Wide range of voltage applications from 100 to 480 Vac
- 10-year free replacement warranty

Optional Features

- Available flushmount for recessed installations

Standards and Certifications

- UL 1449 3rd Edition for surge protective devices
- CE marked
- Vibration tested IEC 60255-21-1 and -2



Catalog Number Selection

CVX050/100

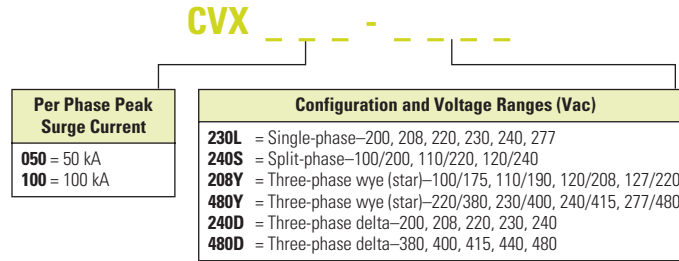

Technical Data and Specifications

CVX050/100 Model Specifications

Description	Specification
kA per phase	50, 100
kA per mode	50
Protection modes	Wye system: L-L, L-N, L-G ^② and N-G/delta system: L-L, L-G split
Wye system voltages ^①	100/175, 110/190, 120/208 , 127/220, 220/380, 230/400, 240/415, 277/480
Delta system voltages ^①	200, 208, 220 , 230, 240 , 380, 400, 415, 440, 480
Split-phase voltages ^①	100/200, 110/220, 120/240
Single-phase voltages ^①	200, 208, 220, 230, 240 , 277
Weight	2.0 lbs (1.0 kg)
Operating temperature	-13°F (-25°C) to +140°F (+60°C)

10

CVX050/100 Let-Through Voltage Ratings

Model Type	System Configuration	Nominal System Voltage	Voltage Protection Ratings				UL VPR ^③ , UL 1449-3			
			MCOV L-N	MCOV L-G	MCOV N-G	MCOV L-L	L-N	L-G	N-G	L-L
CVX050										
230L	Single-phase, two-wire + ground	200, 208, 220, 230, 240, 277	320	640	320	—	1200	2000	1200	—
240S	Split-phase, three-wire + ground	100/200, 110/220, 120/240	150	300	150	300	700	1200	800	1200
208Y	Three-phase wye/star, four-wire + ground	100/175, 110/190, 120/208, 127/220	150	300	150	300	700	1200	800	1200
480Y	Three-phase wye/star, four-wire + ground	220/380, 230/400, 240/415, 277/480	320	640	320	640	1200	2000	1200	2500
240D	Three-phase delta, three-wire + ground	200, 208, 220, 230, 240	—	320	—	320	—	1200	—	2000
480D	Three-phase delta, three-wire + ground	380, 400, 415, 440, 480	—	550	—	1100	—	1800	—	3000
CVX100										
230L	Single-phase, two-wire + ground	200, 208, 220, 230, 240, 277	320	320	320	—	1200	1200	1200	—
240S	Split-phase, three-wire + ground	100/200, 110/220, 120/240	150	150	150	300	700	800	700	1200
208Y	Three-phase wye/star, four-wire + ground	100/175, 110/190, 120/208, 127/220	150	150	150	300	600	700	700	1000
480Y	Split-phase, three-wire + ground	100/200, 110/220, 120/240	320	320	320	640	1200	1200	1200	1800
240D	Three-phase delta, three-wire + ground	200, 208, 220, 230, 240	—	320	—	320	1200	—	—	1800
480D	Three-phase delta, three-wire + ground	380, 400, 415, 440, 480	—	550	—	1100	1800	—	—	3000

Notes

- ① U.S. voltages in bold.
- ② CVX100 model only.
- ③ Test environment: All tests performed with 6-inch lead length, positive polarity. Voltages are peak ±10%.

10.2

SPD, Power Conditioning, PF Capacitors and Harmonic Filters

Surge Protective Devices (SPD)

Dimensions

Approximate Dimensions in Inches (mm)

CVX050/100 Standard Dimensions

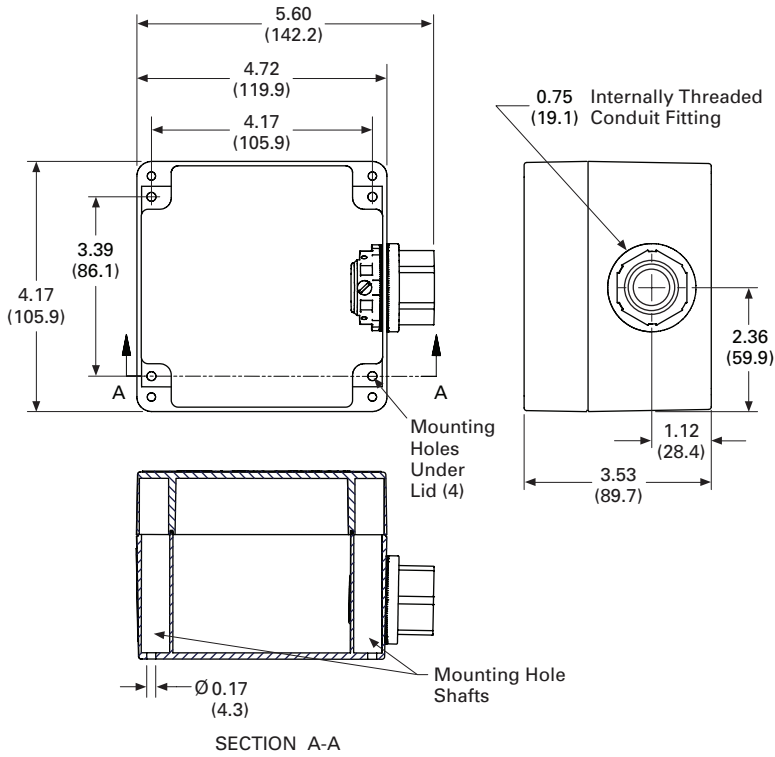

10

Datacom Products



Contents

Description	Page
Product Overview	6
SPD Series for Integration into Electrical Distribution Equipment	8
SPD Series for Mounting External to Electrical Distribution Equipment	12
CVL Surge Protective Device	17
AEGIS Powerline Filters	19
CVX050/100	22

Datacom

Product Description

Eaton’s Datacom surge protection products are designed for all industries and applications. The wide range of products offers rugged surge protection in convenient, easy-to-install configurations.

Features and Benefits

Exceptional performance is achieved using three-stage hybrid technology:

- Gas tubes for shunting high energy
- Silicon avalanche components for responsive, low let-through voltages
- PTC resettable fuses for mitigating fault current
- Our modular design enables customers to protect complete facilities or individual loads. Customers also save significant time and money due to our unique plug-in components and protection modules

Sag Ride Through (SRT)



Sag Ride Through (SRT)

Product Description

Eaton's sag ride through is the first of its kind.

The SRT power conditioner prevents expensive electrical downtime. The SRT represents Eaton's state-of-the-art solution to today's power conditioning challenges.

The Problem—Voltage Sags and Brownouts

The ability of a plant to ride through voltage sags can have a significant impact on operations and competitiveness. In the United States, voltage sags cost billions of dollars in lost production, interruption, damaged materials, retooling and scrap. In addition, sags can cause: increased operating costs, the need for product reworks, safety hazards, equipment damage and/or failure, reduced product quality, increased clean-up, additional labor costs, increased scrap material and costs associated with investigations into the problem.

Today's industrial and large commercial electricity customers are becoming more sensitive to power disturbances and are demanding better electric quality. However, the quality of power grids is not significantly improving. Customers still experience power quality problems that affect plant operations and profitability.

Deep, Single-Phase Sag

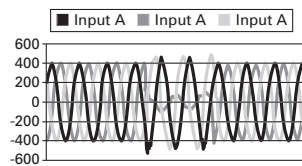

Definition of Voltage Sag

A voltage sag is a sudden, momentary decrease in supply voltage. It can last from a cycle to several seconds. Voltage sags are most often caused by faults on the electrical transmission or distribution system. They can be caused by lightning strikes, animal contact, starting of large motors or an internal fault within a customer's facility.

Contents

Description	Page
Sag Ride Through (SRT)	
Application Description	27
Features, Benefits and Functions	27
Catalog Number Selection	28
Technical Data and Specifications	29
Dimensions	31
Electronic Voltage Regulator (EVR)	32

Depending on the proximity to the fault, which can be hundreds of miles away, the voltage during the sag is typically 40%–90% of nominal utility voltage. The operation of circuit breakers, fuses and reclosers limits most sags to less than 15 cycles.

Voltage sags are experienced 10 to 20 times more frequently than complete outages. However, voltage sags are equally disruptive to sensitive equipment.

Voltage Sags

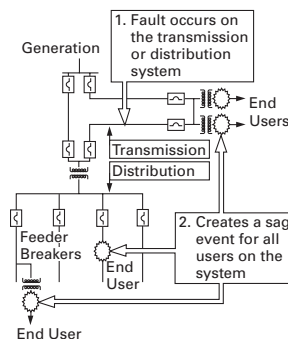

Regularity of Voltage Sags

EPRI conducted a two-year study of power quality levels on distribution systems in the United States. A variation event was recorded every time the voltage dropped below 90% of the nominal. The results are shown below.

A typical distribution system customer experiences about 50 events per year when the voltage drops below 90%, and only about two events per year when the voltage drops below 30% of nominal. The utility study concluded that sags represented almost all of the events experienced at a typical facility.

Events per Year

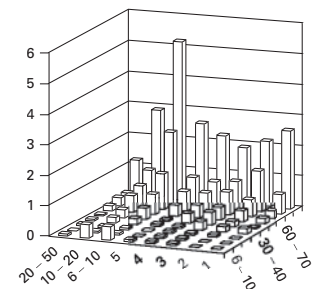

Application Description

Industries and Applications Affected by Sags

Key industries:

- Semi-conductor manufacturers
- Communications
- Steel mills
- Petroleum and chemical processing
- Health care
- Paper mills
- Automotives
- Textile
- Printing
- Plastics
- Other manufacturing

Equipment or processes:

- Manufacturing process controllers
- Variable speed drives
- Robotics
- Motor conductor
- Telephone systems
- HID lighting
- HVAC controls
- Medical equipment
- Computers

Block Diagram of the SRT Active Voltage Conditioner

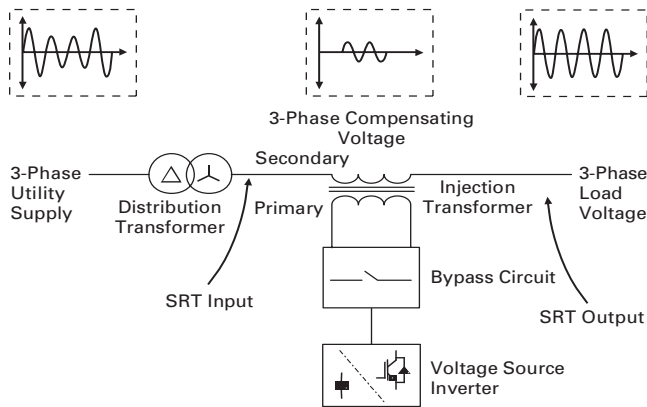

Features, Benefits and Functions

Sag Correction Using the SRT

The SRT is a high performance, inverter-based voltage conditioning device developed to provide protection to sensitive loads against commonly occurring voltage sags.

The SRT monitors the incoming supply voltage and when it deviates from the nominal voltage level, the SRT achieves voltage conditioning by injecting the appropriate correction voltage in series with the power supply. The SRT provides an extremely fast reaction time and subcycle response to sag events that would otherwise cause loads to drop out.

The SRT is designed for low voltage systems (600 to 208, three-phase) and is also offered in medium voltage applications from 25 kVA to 4 MVA. Installation is simple and the SRT provides customers with a new solution to improve productivity and reduce downtime for sag related problems.

The SRT meets the stringent requirements of the Semi-F47 standard; a key requirement for SAG correction in the semiconductor industry.

- Complete correction of single-phase voltage sags down to 63% for 30 seconds
- Partial correction of three-phase sags down to 50% for 30 seconds
- Correction of utility voltage unbalance (from network side of transformer)
- Attenuation of voltage flicker

Continuous Regulation

The Sag Ride Through is an active voltage conditioner. This means it will constantly respond to voltage sags and swells in the $\pm 10\%$ range with a regulated output in the $\pm 1\%$ range. The SRT can be applied to the main service entrance, at branch locations or in front critical loads. The SRT provides an outstanding return on investment. It delivers operation productivity that is just not possible with traditional tap switching or ferroresonant technologies.

The SRT consists of a voltage source inverter, bypass circuit and an injection transformer connected in series between the incoming utility supply and the load, as shown in the figure below. For the standard sag correcting model, the injection transformer consists of a boost component. The SRT monitors the incoming supply voltage and when it deviates from the nominal voltage level the SRT inserts an appropriate compensating voltage using the IGBT inverter and series injection transformer. Energy is sourced from the supply during this time. This regulates the load voltage to its nominal value, thus eliminating voltage disturbances from the utility supply affecting the load.

10.3

SPD, Power Conditioning, PF Capacitors and Harmonic Filters

Power Conditioning Products

Catalog Number Selection

SRT2

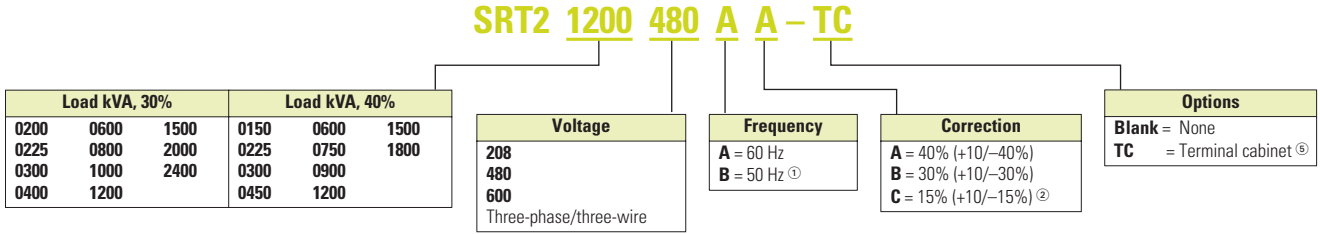

SRT (30% Correction)

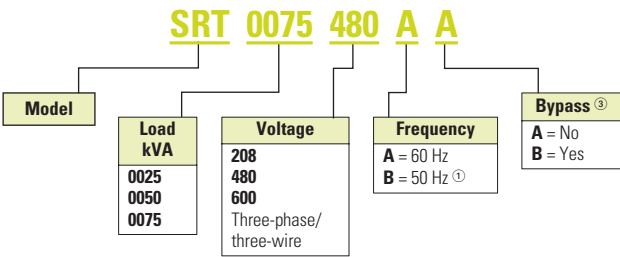

SRTS (40% Correction)

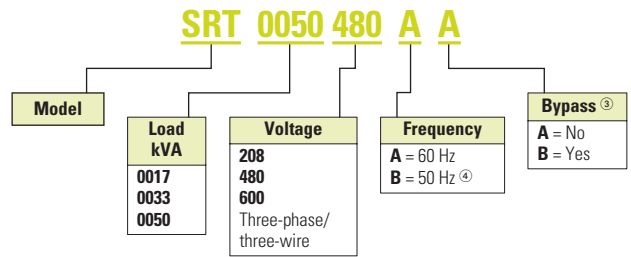

Notes

- ① For 50% Hz international applications, consult factory.
- ② For 15% correction, consult factory.
- ③ Optional mechanical bypass, refer to factory for details.
- ④ For 50 Hz international applications, consult factory.
- ⑤ Terminal cabinet required on all units 200 kVA and larger except when a bypass is required.

Technical Data and Specifications

SRT Specifications

Description	Specifications
Load Capacity	
Capacity (kVA)	25 kVA to 50 MVA (as specified per model)
Displacement power factor of connected load	0–1, leading or lagging
Crest factor for rated kVA	2.0 at 100% of rated load for continuous operation (including up to 10% voltage correction)
Overload—30 seconds	150% with up to 10% of voltage correction
Input Supply	
Nominal supply voltage	208/480/600V, 60 Hz three-phase, three-wire plus ground (higher system voltages supplied to requirement up to 36 kV)
Maximum supply voltage	110% of nominal supply voltage
Minimum three-phase supply voltage	
Running	50% of nominal supply voltage
Starting ^①	75% of nominal supply voltage
Minimum single-phase-to-ground supply voltage ^②	
Running	25% of nominal supply voltage
Starting ^①	63% of nominal supply voltage
Efficiency of system	98–99%
Output Supply	
Nominal voltage (V)	208/480/600V, 60 Hz; three-phase, three-wire plus ground (higher system voltages supplied to requirement)
Three-phase balanced correction	+30% for at least 30 seconds for 100% correction
Single-phase-to-ground correction ^②	+45% for at least 30 seconds; +10% continuous three-phase correction (all models). Consult factory for specialist correction requirements.
Voltage regulation	±1% up to 10% continuous three-phase correction ±2.5% at 30% three-phase correction
Response (to sag event)	Initial sag correction applied within 1 ms, remainder over the next cycle
Response to swell event	±1% up to a 10% continuous three-phase correction with initial swell correction applied within 1 ms, remainder over the next cycle (SRT2 models only)
Bypass	
Nominal power	SRT rating (kVA)
Maximum overload capacity (in bypass):	
For 10 minutes (%)	125
For 1 minute (%)	150
For 600 milliseconds (%)	700
For 100 milliseconds (%)	1000
Transfer time ^③	
Inverter to bypass (ms)	<0.5
Bypass to inverter (ms)	<40–750
Environmental	
Operating temperature	32°F to 104°F (0 to 40°C); 122°F (50°C) maximum with 20% load derating
Cooling	Forced ventilation
Capacity derating with elevation	–1.2% every 100m above 1000m
Humidity	<95%, noncondensing
Warranty	1 year

Notes

- ^① If SRT has tripped (offline) due to below threshold input voltages, it cannot be restarted until the system voltage is at least this % of the nominal.
- ^② Single-phase-to-ground fault occurring on the utility side of a delta-wye distribution transformer.
- ^③ The SRT provides continuous correction and only transitions to and from bypass when manually starting and stopping or under fault or overload conditions. The transition from bypass to inverter takes up to 750 ms. The autoresettable bypass mode of operation includes an additional 5-second delay allowing time for the fault to clear.

10.3

SPD, Power Conditioning, PF Capacitors and Harmonic Filters

Power Conditioning Products

System Capacities

Model Number	Load Capacity at Normal Voltage 480V (kVA)	Fault Capacity (kVA)	System Efficiency (%)	System Dissipation (Worst Case) (kW)	Airflow (mm ³ /min)
40% Correction					
SRT20150480AA	150	40	97.55	3.8	18
SRT20225480AA	225	40	97.77	5.2	18
SRT20300480AA	300	40	98.00	6.1	18
SRT20450480AA	450	40	98.22	8.0	36
SRT20600480AA	600	40	98.44	9.8	36
SRT20750480AA	750	40	98.44	12.2	54
SRT20900480AA	900	40	98.55	13.2	54
SRT21200480AA	1200	40	98.55	18.1	72
SRT21500480AA	1500	50	98.77	20.22	90
SRT21800480AA	1800	50	98.88	22.11	108
30% Correction					
SRT20150480AB	150	40	98.55	2.85	18
SRT20200480AB	200	40	98.55	3.80	18
SRT20225480AB	225	40	98.66	4.30	18
SRT20300480AB	300	40	98.66	5.20	18
SRT20400480AB	400	40	98.88	6.10	18
SRT20600480AB	600	40	99.00	8.00	36
SRT20800480AB	800	40	99.11	9.80	36
SRT21000480AB	1000	40	99.11	12.20	54
SRT21200480AB	1200	40	99.33	13.20	54
SRT21500480AB	1500	40	99.22	18.10	72
SRT22000480AB	2000	50	99.33	20.20	90
SRT22400480AB	2400	50	99.44	22.11	108

Dimensions

Approximate Dimensions in Inches (mm)

SRT2, SRT and SRTS

Model Number	Cabinet Dimensions		
	Height	Width	Depth
SRT2 40% Correction			
SRT20150480AA	85.00 (2159.0)	64.00 (1625.6)	32.00 (812.8)
SRT20225480AA	85.00 (2159.0)	64.00 (1625.6)	32.00 (812.8)
SRT20300480AA	85.00 (2159.0)	64.00 (1625.6)	32.00 (812.8)
SRT20450480AA	85.00 (2159.0)	64.00 (1625.6)	32.00 (812.8)
SRT20600480AA	85.00 (2159.0)	64.00 (1625.6)	32.00 (812.8)
SRT20750480AA	85.00 (2159.0)	96.00 (2438.4)	96.00 (2438.4)
SRT20900480AA	85.00 (2159.0)	96.00 (2438.4)	96.00 (2438.4)
SRT21200480AA	85.00 (2159.0)	126.00 (3200.4)	96.00 (2438.4)
SRT21500480AA	85.00 (2159.0)	126.00 (3200.4)	96.00 (2438.4)
SRT21800480AA	85.00 (2159.0)	126.00 (3200.4)	96.00 (2438.4)
SRT2 30% Correction			
SRT20150480AB	85.00 (2159.0)	64.00 (1625.6)	32.00 (812.8)
SRT20200480AB	85.00 (2159.0)	64.00 (1625.6)	32.00 (812.8)
SRT20225480AB	85.00 (2159.0)	64.00 (1625.6)	32.00 (812.8)
SRT20300480AB	85.00 (2159.0)	64.00 (1625.6)	32.00 (812.8)
SRT20400480AB	85.00 (2159.0)	64.00 (1625.6)	32.00 (812.8)
SRT20600480AB	85.00 (2159.0)	64.00 (1625.6)	32.00 (812.8)
SRT20800480AB	85.00 (2159.0)	64.00 (1625.6)	32.00 (812.8)
SRT21000480AB	85.00 (2159.0)	96.00 (2438.4)	32.00 (812.8)
SRT21200480AB	85.00 (2159.0)	96.00 (2438.4)	32.00 (812.8)
SRT21500480AB	85.00 (2159.0)	126.00 (3200.4)	96.00 (2438.4)
SRT22000480AB	85.00 (2159.0)	126.00 (3200.4)	96.00 (2438.4)
SRT22400480AB	85.00 (2159.0)	126.00 (3200.4)	96.00 (2438.4)
SRT/SRTS 40% Correction			
SRTS17480AA	24.00 (609.6)	24.00 (609.6)	36.00 (914.4)
SRTS30480AA	24.00 (609.6)	24.00 (609.6)	36.00 (914.4)
SRTS50480AA	24.00 (609.6)	24.00 (609.6)	36.00 (914.4)
SRT/SRTS 30% Correction			
SRT25408AB	24.00 (609.6)	24.00 (609.6)	36.00 (914.4)
SRT50408AB	24.00 (609.6)	24.00 (609.6)	36.00 (914.4)
SRT75408AB	24.00 (609.6)	24.00 (609.6)	36.00 (914.4)

Electronic Voltage Regulator (EVR) Tap Changer



Contents

<i>Description</i>	<i>Page</i>
Sag Ride Through (SRT)	26
Electronic Voltage Regulator (EVR) (EVR)	
Catalog Number Selection	33
Technical Data and Specifications	33

Electronic Voltage Regulator (EVR)

Product Description

Eaton's Electronic Voltage Regulator (EVR) is the ideal solution for keeping your facility and equipment up and running during brownouts, undervoltage conditions and other power problems. The EVR can significantly reduce the costs of equipment damage and downtime when these situations occur. The state-of-the-art design provides rapid response time, high efficiency, high inrush current capability, and operating advantages exclusive to Eaton.

The EVR maintains a tightly regulated output voltage by automatically activating the appropriate transformer tap through a silicone controlled rectifier (SCR). Tap changer response time is initiated at one cycle, ensuring rapid and precise regulation. Switching at zero current enables noise reduction during tap transitions.

Brownouts

In the United States, most facilities have sufficient voltage regulation. However, in some U.S. locations and many developing countries, regulation problems occur because of overstressed utility distribution systems.

In some cases, due to the excessive demand on the utility system, voltage may be below 10% of nominal (-10%) during the day. This condition is called a **voltage regulation or brownout**.

Customers may notice dim lights and reduced power. During the evening, voltage may rise above 10% of nominal (+10%) because large facilities and loads are shut down. This shutdown reduces the power demand on the grid and results in a voltage increase.

The IEEE defines voltage regulation as overvoltage or undervoltage. Voltage regulation events last from **a few minutes to many hours** with voltage varying by $\pm 20\%$. Long-term regulation problems differ from short duration sags and dips, which are much deeper voltage drops.

The Solution

Prior to installing an expensive solution, Eaton encourages customers to monitor incoming voltage to determine if voltage regulation is a problem. The local utility may also be able to provide information on voltage expected at the facility.

Using a meter, it can quickly be determined if a voltage regulation problem or brownout condition exists. The appropriate solution would be an EVR. EVRs can be installed at the service entrance, branch panel or at critical loads.

Eaton's EVR is a solid-state tap changing power conditioner designed to protect against brownouts and long duration voltage regulation problems.

Features and Benefits

- Coordinated with standard thermal-magnetic breakers to allow motor starts
- Optional 100 kA per phase surge protection
- Input frequency range operation from 57–63 Hz
- Not affected by load power factor. Can operate effectively in low-load applications due to "unique leakage reactance" technology
- Fail-safe bypass circuit, isolation transformer and overtemperature protection
- Less than 1% THD
- Monitoring panel displays rms metering, output voltage and current, kVA, under- and overvoltage, phase rotation, phase loss, first and second stage temperature alarm, shut-off, EPO tripped and eight optional external ports

Catalog Number Selection

EVR

EVR 025 208D 400Y B S M1

kVA Ratings and Dimensions			
kVA	Weight Lbs (kg)	BTUs/hr	Dimensions in Inches (mm) (W x D x H)
010	440 (199.8)	1705	21.00 x 29.00 x 30.00 (533.4 x 736.6 x 762.0)
015	520 (236.1)	2557	21.00 x 29.00 x 30.00 (533.4 x 736.6 x 762.0)
025	700 (317.8)	2560	21.00 x 29.00 x 44.00 (533.4 x 736.6 x 1117.6)
030	720 (326.9)	3090	21.00 x 29.00 x 44.00 (533.4 x 736.6 x 1117.6)
045	950 (431.3)	4600	45.00 x 29.00 x 44.00 (1143.0 x 736.6 x 1117.6)
050	950 (431.3)	5525	45.00 x 29.00 x 44.00 (1143.0 x 736.6 x 1117.6)
075	1100 (499.4)	12,787	45.00 x 29.00 x 44.00 (1143.0 x 736.6 x 1117.6)
100	1660 (753.6)	17,050	45.00 x 29.00 x 44.00 (1143.0 x 736.6 x 1117.6)
125	1980 (898.9)	21,312	45.00 x 29.00 x 44.00 (1143.0 x 736.6 x 1117.6)
150	2200 (998.8)	25,575	45.00 x 29.00 x 44.00 (1143.0 x 736.6 x 1117.6)
225	3300 (1498.2)	23,000	56.00 x 41.50 x 77.00 (1422.4 x 1054.1 x 1955.8)
300	4000 (1816.0)	30,750	56.00 x 41.50 x 77.00 (1422.4 x 1054.1 x 1955.8)
500	5500 (2497.0)	51,250	72.00 x 48.50 x 77.00 (1828.8 x 1231.9 x 1955.8)

Nominal Input Voltage (Delta Input: L, L, L, G)
208D = 208D
240D = 240D
400D = 400D
480D = 480D
600D = 600D

Nominal Output Voltage (Wye Output: L, L, L, N, G)
208Y = 120/208
400Y = 230/400
480Y = 277/480
600Y = 347/600

Surge Protection
X = No
S = Yes

Frequency
A = 60 Hz
B = 50 Hz

Options
M1 = IQ 110 Meter
M2 = IQ 260 Meter
B = Bypass

Technical Data and Specifications

EVR Specification (10 to 1250 kVA)

Feature	Description
Technology	Electronic tap changer
Input voltages	240–600 Vac; three-phase (three-wire)
Input voltage range	+10/–23%
Output voltage range	± 3% typical
Response time	One cycle, zero current switching
Frequency	60 Hz standard (other frequencies available)
Efficiency	96% at full load, 98.5% at light loads
Minimum load	None
Inrush current capabilities	1000% for one cycle; 200% for 10 seconds; or as limited by upstream overcurrent protection
Noise attenuation	
Common mode	–120 dB at 100 kHz
Normal mode	–40 dB at 100 kHz
Monitoring (option)	Refer to “Features and Benefits” for details
Bypass panel	Optional (10–45 kVA), standard (50–500 kVA)
Front access panel	50–150 kVA standard
Surge protection device (option)	100 kA per phase
Operating temperature	32°F to 122°F (0 to 50°C)
Altitude	Up to 7000 ft (2134m)
Standard warranty	12/18 months
Extended warranty (startup service)	12/18 months factory on-site warranty

Notes

All weights are approximate. Monitor option includes main input circuit breaker. Refer to PAD for pricing and availability.

10.4

SPD, Power Conditioning, PF Capacitors and Harmonic Filters

Power Factor Correction Capacitors

Capacitor Cell With M12 Threaded Mounting Bolt, Washer, Nut



10

Product Overview

Product Description

Eaton's power factor correction capacitors and harmonic filters are an essential part of modern electric power systems. Power factor correction capacitors are the simplest and most economical means of increasing the capacity of any power system, minimizing energy losses and correcting load power factor. In addition, power factor penalties can be reduced and power quality can be greatly enhanced.

There are several reasons to correct poor power factor. The first is to reduce or eliminate a power factor penalty charged by the utility. Another reason is that your existing transformer is, or shortly will be, at full capacity and installing power factor correction capacitors can be a very cost-effective solution to installing a brand new service. Depending on the amount of power factor correction (kVAR that needs to be injected into the electrical system to improve the power factor) and the dynamic nature of the load, a fixed or switched capacitor bank may be the best solution.

Contents

<i>Description</i>	<i>Page</i>
Product Overview	
Product Selection	35
Dimensions	36
UNIPUMP	37
UNIPAK	40
AUTOVAR 300 Automatic Power Factor Correction Capacitor Systems	51
AUTOVAR 600 Automatic Power Factor Correction Capacitor Systems	54
AUTOVAR Filter—LV Automatic Harmonic Filter	59
Transient-Free Static Switching Power Factor Correction Units	63
Active-Harmonic Filter-Harmonic Correction Unit—NEMA 1 Enclosure	67

When capacity becomes a problem, the choice of a solution will be dependent upon the size of the increase needed. Like all power quality solutions, there are many factors that need to be considered when determining which solution will be best to solve your power factor problem.

Harmonic Filtering

As the world becomes more dependent on electric and electronic equipment, the likelihood that the negative impact of harmonic distortion increases dramatically. The efficiency and productivity gains from these increasingly sophisticated pieces of equipment have a negative side effect...increased harmonic distortion in the power lines. The difficult thing about harmonic distortion is determining the cause. Once this has been determined, the solution can be easy. Passive and active harmonic filtering equipment will mitigate specific harmonic issues, and correct poor power factor as well.

Product Selection

1543PCRMA



Capacitor Cell Chart

Voltage	kVAR	Part Number
240	1.5	643PCRMA
240	2	8B43PCRMA
240	2.5	1043PCRMA
240	3	12X43PCRMA
240	4	423PCRMA
240	5	2043PCRMA
240	6.3	6B23PCRMA
240	7.5	7X23PCRMA
240	8.3	8B23PCRMA
240	10	1023PCRMA
240	12.5	12X23PCRMA
240	15	1523PCRMA
240	16.7	16S23PCRMA
240	17.5	17X23PCRMA
480	1.5	1X43PCRMA
480	2	243PCRMA
480	2.5	2X43PCRMA
480	3	343PCRMA
480	4	443PCRMA
480	5	543PCRMA
480	6	643PCRMA
480	7.5	7X43PCRMA
480	8.3	8B43PCRMA
480	9	943PCRMA
480	10	1043PCRMA
480	12.5	12X43PCRMA
480	15	1543PCRMA
480	18	1843PCRMA
480	20	2043PCRMA
480	25	2543PCRMA
480	30	3043PCRMA
600	5	563PCRMA
600	7.5	7X63PCRMA
600	10	1063PCRMA
600	12.5	12X63PCRMA
600	15	1563PCRMA
600	17.5	2063PCRMA
600	20	2563PCRMA

Harmonic Rated Capacitor Cell Chart

Voltage	kVAR	Part Number
240	12.5	12X23PHRMA
480	15.0	1543PHRMA
480	25.0	2543PHRMA
600	12.3	12A63PHRMA
600	14.7	14S63PHRMA
600	16.7	16S63PHRMA

Note

kVAR rating standard. NEMA kVAR tolerance is +15% to 0%. Part number shown is for three-phase units. Up to 5 kVAR at 480V—fast-on terminals are standard. Above 5 kVAR at 480V (and on all other voltages)—sigut terminals are standard. For dimensions and weights, see following page.

10.4

SPD, Power Conditioning, PF Capacitors and Harmonic Filters

Power Factor Correction Capacitors

Dimensions

Approximate Dimensions in Inches (mm)

Capacitor Cell Chart

Part Number	Depth	Height	Weight in Lbs (kg)
643PCRMA	3.10 (78.7)	7.90 (200.7)	1.1 (0.5)
8B43PCRMA	3.10 (78.7)	9.40 (238.8)	1.3 (0.6)
1043PCRMA	3.10 (78.7)	9.40 (238.8)	1.3 (0.6)
12X43PCRMA	3.50 (88.9)	9.40 (238.8)	1.8 (0.8)
423PCRMA	3.10 (78.7)	7.90 (200.7)	1.1 (0.5)
2043PCRMA	3.50 (88.9)	12.30 (312.4)	2.6 (1.2)
6B23PCRMA	3.10 (78.7)	9.40 (238.8)	1.3 (0.6)
7X23PCRMA	3.10 (78.7)	9.40 (238.8)	1.3 (0.6)
8B23PCRMA	3.50 (88.9)	9.40 (238.8)	1.8 (0.8)
1023PCRMA	3.50 (88.9)	9.40 (238.8)	1.3 (0.6)
12X23PCRMA	3.50 (88.9)	12.30 (312.4)	2.6 (1.2)
1523PCRMA	3.50 (88.9)	12.30 (312.4)	2.6 (1.2)
16S23PCRMA	3.50 (88.9)	15.30 (388.6)	3.3 (1.5)
17X23PCRMA	3.50 (88.9)	15.30 (388.6)	3.3 (1.5)
1X43PCRMA	2.10 (53.3)	5.00 (127.0)	0.7 (0.3)
243PCRMA	2.50 (63.5)	5.50 (139.7)	0.9 (0.4)
2X43PCRMA	2.50 (63.5)	5.50 (139.7)	0.9 (0.4)
343PCRMA	2.50 (63.5)	5.50 (139.7)	0.9 (0.4)
443PCRMA	2.50 (63.5)	6.50 (165.1)	0.9 (0.4)
543PCRMA	2.50 (63.5)	6.50 (165.1)	0.9 (0.4)
643PCRMA	3.10 (78.7)	7.90 (200.7)	1.1 (0.5)
7X43PCRMA	3.10 (78.7)	7.90 (200.7)	1.1 (0.5)
8B43PCRMA	3.10 (78.7)	9.40 (238.8)	1.3 (0.6)
943PCRMA	3.10 (78.7)	9.40 (238.8)	1.3 (0.6)
1043PCRMA	3.10 (78.7)	9.40 (238.8)	1.3 (0.6)
12X43PCRMA	3.50 (88.9)	9.40 (238.8)	1.8 (0.8)
1543PCRMA	3.50 (88.9)	9.40 (238.8)	1.8 (0.8)
1843PCRMA	3.50 (88.9)	12.30 (312.4)	2.6 (1.2)
2043PCRMA	3.50 (88.9)	12.30 (312.4)	2.6 (1.2)
2543PCRMA	3.50 (88.9)	12.30 (312.4)	2.6 (1.2)
3043PCRMA	3.50 (88.9)	15.30 (388.6)	3.3 (1.5)
563PCRMA	3.10 (78.7)	9.40 (238.8)	1.3 (0.6)
7X63PCRMA	3.10 (78.7)	9.40 (238.8)	1.3 (0.6)
1063PCRMA	3.10 (78.7)	9.40 (238.8)	1.3 (0.6)
12X63PCRMA	3.50 (88.9)	9.40 (238.8)	1.8 (0.8)
1563PCRMA	3.50 (88.9)	12.30 (312.4)	2.6 (1.2)
2063PCRMA	3.50 (88.9)	12.30 (312.4)	2.6 (1.2)
2563PCRMA	3.50 (88.9)	15.30 (388.6)	3.3 (1.5)

Harmonic Rated Capacitor Cell Chart

Part Number	Depth	Height	Weight in Lbs (kg)
12X23PHRMA	3.50 (88.9)	15.30 (388.6)	3.3 (1.5)
1543PHRMA	3.50 (88.9)	12.30 (312.4)	2.6 (1.2)
2543PHRMA	3.50 (88.9)	15.30 (388.6)	3.3 (1.5)
12A63PHRMA	3.50 (88.9)	12.30 (312.4)	2.6 (1.2)
14S63PHRMA	3.50 (88.9)	15.30 (388.6)	3.3 (1.5)
16S63PHRMA	3.50 (88.9)	15.30 (388.6)	3.3 (1.5)

Capacitor Cell

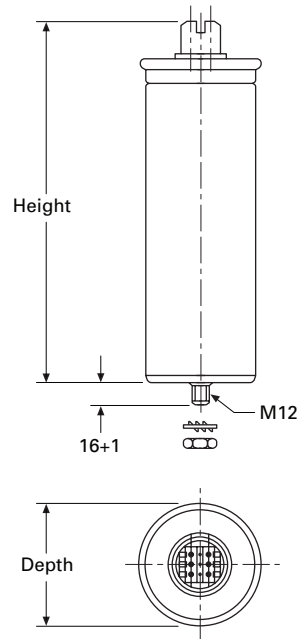

UNIPUMP



UNIPUMP

Product Description

Non-fused capacitors for outdoor irrigation and oil field installations.

- Designed expressly for outdoor pumping applications
- Pole or wall mounting
- Small, light-weight enclosure for easy installation
- SO-WA type flexible cable facilitates installation (4-conductor)
- Gland-type weatherproof bushings
- Strong outer case

Application Description

Outdoor irrigation and oil and gas field pumping.

Features, Benefits and Functions

Configuration

- **Outer case:** Heavy, No. 14 gauge steel finished with durable powder coat finish. Integral strap mounting bracket with keyhole at top for pole or wall installation. No knockouts

Capacitor Cells

- **Terminals:** Insulated finger-safe terminals rated for 3 kVAC withstand
- **Dielectric fill:** Dry-type cells utilize soft organic polymer resin—Resinol
- Eliminates potential for corona/partial discharge/electrochemical oxidation
- Excellent heat dissipation
- Flash point: +444°F (+229°C)
- Fire point: +840°F (+449°C)

Contents

Description	Page
Product Overview	34
UNIPUMP	
Product Selection	38
Dimensions	39
UNIPAK	40
AUTOVAR 300 Automatic Power Factor Correction Capacitor Systems	51
AUTOVAR 600 Automatic Power Factor Correction Capacitor Systems	54
AUTOVAR Filter—LV Automatic Harmonic Filter	59
Transient-Free Static Switching Power Factor Correction Units	63
Active-Harmonic Filter-Harmonic Correction Unit—NEMA 1 Enclosure	67

- **Design:** Self-healing metallized high crystalline polypropylene with ramp metallization film. Total losses less than 0.45 watt per kVAR. (Dielectric losses less than 0.2 watt per kVAR)
- **Ramp metallization:** Provides thicker film at higher current density areas, allowing for reduced internal losses, lower operating temperatures and longer life expectancy. Also prevents chain reaction breakdown by limiting propagation of film vaporization
- **Pressure sensitive interrupter:** Built-in, three-phase pop-up interrupter design. UL recognized. Removes capacitor from line before internal pressure can cause case rupture. Bulged capacitor cell top provides easy visual indication of interrupter operation
- **Ceramic discharge resistors:** Reduce residual voltage to less than 50 volts within one minute of de-energization. Selected for 20-year nominal life. Exceeds NEC requirements
- **Capacitor operating temperature:** -40°F (-40°C) to +115°F (+46°C)
- **Case:** Weatherproof aluminum housing
- **Warranty:** The longest in the industry—five full years of warranty on capacitor cells

Standards and Certifications

- UL and CSA listed



10.4

SPD, Power Conditioning, PF Capacitors and Harmonic Filters

Power Factor Correction Capacitors

Product Selection

UNIPUMP



UNIPUMP

kVAR	Rated Current	Case Size	Cable Size	Shipping Weight in Lbs (kg)	Catalog Number
240 Vac					
2	4.8	AA	14.0	10.0 (4.5)	223JMR
2.5	6.0	AA	14.0	10.0 (4.5)	2X23JMR
3	7.2	AA	14.0	10.0 (4.5)	323JMR
4	9.6	AA	14.0	11.0 (5.0)	423JMR
5	12.0	AA	14.0	11.0 (5.0)	523JMR
6	14.4	BB	12.0	15.0 (6.8)	623JMR
7.5	18.0	BB	12.0	15.0 (6.8)	7X23JMR
480 Vac					
2	2.4	AA	14.0	10.4 (4.7)	243JMR
2.5	3.0	AA	14.0	10.4 (4.7)	2X43JMR
3	3.6	AA	14.0	10.4 (4.7)	343JMR
4	4.8	AA	14.0	10.4 (4.7)	443JMR
5	6.0	AA	14.0	10.4 (4.7)	543JMR
6	7.2	AA	14.0	10.6 (4.8)	643JMR
7.5	9.0	AA	14.0	10.6 (4.8)	7X43JMR
10	12.0	AA	14.0	10.8 (4.9)	1043JMR
12.5	15.0	BB	12.0	15.0 (6.8)	12X43JMR
15	18.0	BB	12.0	15.0 (6.8)	1543JMR
17.5	21.0	BB	8.0	15.8 (7.2)	17X43JMR
20	24.0	BB	8.0	16.8 (7.6)	2043JMR
25	30.0	BB	8.0	16.8 (7.6)	2543JMR
600 Vac					
5	4.9	AA	14.0	10.8 (4.9)	563JMR
7.5	7.4	AA	14.0	10.8 (4.9)	7X63JMR
10	9.8	AA	14.0	10.8 (4.9)	1063JMR
12.5	12.3	AA	12.0	15.0 (6.8)	12X63JMR
15	14.7	BB	12.0	15.8 (7.2)	1563JMR
17.5	17.2	BB	8.0	16.8 (7.6)	17X63JMR
20	19.6	BB	8.0	16.8 (7.6)	2063JMR

Dimensions

Approximate Dimensions in Inches (mm)

UNIPUMP

UNIPUMP Dimension Chart

Size Code	A	B	C	D
AA	11.00 (279.4)	14.20 (360.7)	12.60 (320.0)	13.20 (335.3)
BB	14.00 (355.6)	17.10 (434.3)	15.50 (393.7)	16.10 (408.9)

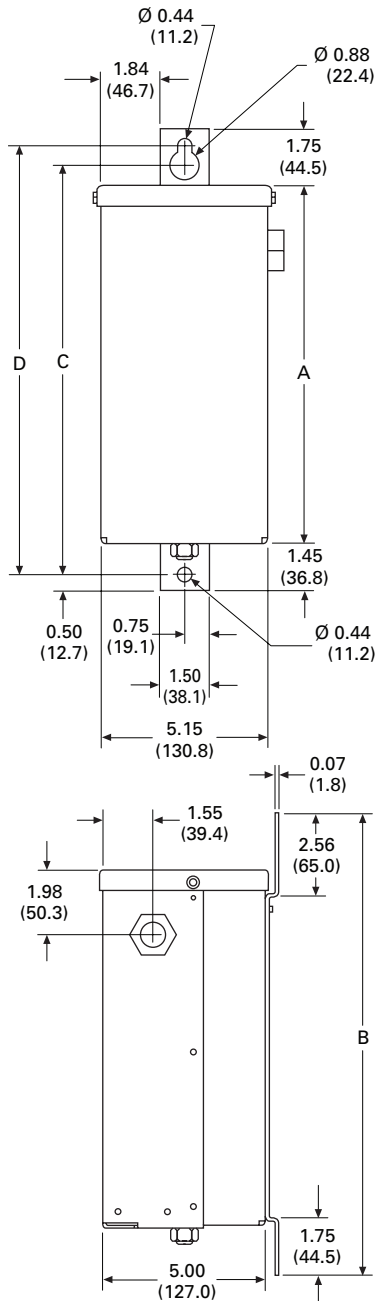

UNIPAK

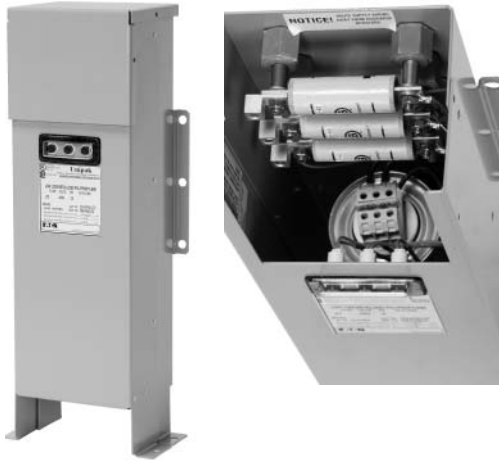

10

UNIPAK

Product Description

UNIPAK Filter— Harmonic Filtering

Harmonic filter systems for low voltage, heavy-duty applications.

- Reduce harmonics and correct power factor
- Tuned for maximum efficiency in reducing harmonic currents associated with nonlinear load environments (such as VFDs)
- Two-enclosure design isolates capacitors from high-temperature operating reactors, and allows for flexible installation
- Twenty-year life design
- Five-year cell warranty/ one-year reactor warranty
- Three-phase cell capacitor construction. Three-phase interrupter system

Harmonic Rated Capacitor Cells

- Standard voltage rated capacitor cells designed for higher dielectric strength and with added ability to withstand stress caused by dv/dt voltage transients caused by harmonics
- Better suited for harmonic applications than higher voltage rated cells

UNIPAK with Harmonic Rated Capacitor Cells

- Standard capacitor systems utilizing harmonic rated capacitor cells
- For use in moderate harmonic environments where engineering supervision allows in place of harmonic filter designs
- Provides future conversion capability into a harmonic filter design due to facility growth or increased nonlinear load levels

Contents

Description	Page
Product Overview	34
UNIPUMP	37
UNIPAK	
Features, Benefits and Functions	41
Standards and Certifications	41
Product Selection	42
Dimensions	49
AUTOVAR 300 Automatic Power Factor Correction Capacitor Systems	51
AUTOVAR 600 Automatic Power Factor Correction Capacitor Systems	54
AUTOVAR Filter—LV Automatic Harmonic Filter	59
Transient-Free Static Switching Power Factor Correction Units	63
Active-Harmonic Filter-Harmonic Correction Unit—NEMA 1 Enclosure	67

Application Description

Designed for power factor correction in plants experiencing harmonics problems due to high amounts of nonlinear loads.



UNIPAK with Optional Air Filter

Features, Benefits and Functions

- Five-year warranty on capacitor cells
- Designed for heavy-duty applications
- Twenty-year life design
- Indoor/outdoor service
- Wall (up to 180 kVAR) and floor-mounted units available
- Fuse protection standard
- Blown-fuse indicating lights standard
- Quick lead-times
- Harmonic filters available
- Slim profile allows reduced footprint, conserving valuable floor space
 - New capacitor configuration leads to cooler operating conditions, extending capacitor life

Configuration

- **Outer case:** Heavy, No. 14 gauge steel finished with durable powder coat finish. Wall mounting flanges and floor mounting feet. Elimination of knockouts permits indoor/outdoor use. Manufactured to NEMA requirements 1, 3R and 12
- Elevated floor mounting feet allow access for easy maintenance

Note: NEMA 12 enclosure standard for enclosure sizes A1 to C1.

- **Cover:** "L" shaped gasketed cover with multiple fasteners provides front opening for ease of installation and service
 - **Ground terminal:** Furnished inside case
 - **Power terminal lugs:** Large size provided for easy connection
 - **Fusing:**
 - **Size Code A1:** Three midget-type fuses with 100,000 ampere interrupting capacity
 - **Size Code A2 and larger:** Three slotted-blade type fuses with 200,000 ampere interrupting capacity; Fuses mounted on stand-off bushings or fuse blocks; solderless connectors for easy hookup of incoming line conductors
 - **Fuse indicating lights:** Red, neon blown-fuse indicating lights are protected by transparent weatherproof guard
 - **Options:**
 - No fuses
 - Air filters for units with enclosure sizes C2, D1 and E1
- Capacitor cells**
- **Terminals:** Insulated finger-safe terminals rated for 3 kVAC withstand
 - **Dielectric fill:** Dry-type cells utilize soft organic polymer resin—Resinol
 - Eliminates potential for corona/partial discharge/electrochemical oxidation
 - Excellent heat dissipation
 - Flash point: +444°F (+229°C)
 - Fire point: +840°F (+449°C)
 - **Design:** Self-healing metallized high crystalline polypropylene with ramp metallization film. Total losses less than 0.45 watt per kVAR. (Dielectric losses less than 0.2 watt per kVAR)
 - **Ramp metallization:** Provides thicker film at higher current density areas, allowing for reduced internal losses, lower operating temperatures and longer life expectancy. Also prevents chain reaction breakdown by limiting propagation of film vaporization
 - **Pressure sensitive interrupter:** Built-in, three-phase pop-up interrupter design. UL recognized. Removes capacitor from line before internal pressure can cause case rupture. Bulged capacitor cell top provides easy visual indication of interrupter operation
 - **Ceramic discharge resistors:** Reduce residual voltage to less than 50 volts within one minute of de-energization. Selected for 20-year nominal life. Exceeds NEC requirements

- **Capacitor operating temperature:** -40°F (-40°C) to +115°F (+46°C)
- **Case:** Weatherproof aluminum housing
- **Warranty:** The longest in the industry—five full years of warranty on capacitor cells

Reactors

- **Tuning:** Tuned to 4.7 harmonic order
- **Detuning:** Reactor designs can be detuned upon request to 4.2nd to protect capacitors against alternate harmonics
- **Construction:** 100% copper windings for cool operating temperatures; designed operating temperature rise less than 80°C. Open frame construction with 220°C insulation system
- **Thermal sensors:** One per phase, self-resetting thermistors provide reactor over-temperature protection and indication
- **Reactor indicating light:** Thermal overload indicating light activates when reactor temperature reaches 180°C
- **Warranty:** One-year replacement of reactors

Standards and Certifications

- UL and CSA listed



10.4

SPD, Power Conditioning, PF Capacitors and Harmonic Filters

Power Factor Correction Capacitors

Product Selection

UNIPAK Low Voltage Fixed Capacitor Banks

UNIPAK

240 Vac UNIPAK



kVAR	Rated Current	Enclosure	Shipping Weight in Lbs (kg)	Part Number
1	2.4	A1	18 (8)	123PMURF
1.5	3.6	A1	18 (8)	1X23PMURF
2	4.8	A1	19 (9)	223PMURF
2.5	6	A1	19 (9)	2X23PMURF
3	7.2	A1	19 (9)	323PMURF
4	9.6	A1	20 (9)	423PMURF
5	12	A2	29 (13)	523PMURF
6	14.4	A2	29 (13)	623PMURF
7.5	18	A2	30 (14)	7X23PMURF
8	19.2	A2	31 (14)	823PMURF
10	24	A2	31 (14)	1023PMURF
12.5	30	A2	32 (14)	12X23PMURF
15	36	A2	33 (15)	1523PMURF
17.5	42	B1	44 (20)	17X23PMURF
20	48	B1	45 (20)	2023PMURF
22.5	54	B1	46 (21)	22X23PMURF
25	60	B1	46 (21)	2523PMURF
30	72	B1	47 (21)	3023PMURF
32.5	78	B1	47 (22)	32X23PMURF
35	84	B1	48 (22)	3523PMURF
40	96	C1	64 (29)	4023PMURF
42.5	102	C1	65 (30)	42X23PMURF
45	108	C1	66 (30)	4523PMURF
50	120	C1	68 (31)	5023PMURF
60	144	C1	69 (31)	6023PMURF
70	168	C2	99 (45)	7023PMURF
75	180	C2	100 (46)	7523PMURF
80	192	C2	101 (46)	8023PMURF
90	216	C2	103 (47)	9023PMURF
100	240	C2	104 (47)	10023PMURF
120	288	D1	133 (60)	12023PMURF
140	336	D1	137 (62)	14023PMURF
150	360	D1	140 (64)	15023PMURF
160	384	E1	175 (80)	16023PMURF
180	432	E1	182 (83)	18023PMURF
200	480	E1	189 (86)	20023PMURF

Notes

Multiply the 240 Vac kVAR rating by 0.75 to calculate the kVAR value at 208 Vac.

Fused with blown-fuse indication available standard. Non-fused and no lights also available—please consult the factory.

Other ratings available, consult factory.

For dimensional information, refer to **Page 49**.

Part Numbers:

PMURF—three fuses + three lights

PMURN—non-fused

UNIPAK

480 Vac UNIPAK



kVAR	Enclosure	Rated Current	Shipping Weight in Lbs (kg)	Part Number
1.5	A1	1.8	17 (8)	1X43PMURF
2	A1	2.4	18 (8)	243PMURF
2.5	A1	3	18 (8)	2X43PMURF
3	A1	3.6	19 (9)	343PMURF
4	A1	4.8	19 (9)	443PMURF
5	A1	6	19 (9)	543PMURF
6	A1	7.2	19 (9)	643PMURF
7.5	A1	9	20 (9)	7X43PMURF
8	A1	9.6	20 (9)	843PMURF
9	A1	10.8	20 (9)	943PMURF
10	A1	12	20 (9)	1043PMURF
12.5	A2	15	29 (13)	12X43PMURF
15	A2	18	29 (13)	1543PMURF
17.5	A2	21	30 (14)	17X43PMURF
20	A2	24	31 (14)	2043PMURF
22.5	B1	27	44 (20)	22X43PMURF
25	A2	30	32 (15)	2543PMURF
27.5	B1	33	44 (20)	27X43PMURF
30	B1	36	44 (20)	3043PMURF
32.5	B1	39	45 (20)	32X43PMURF
35	B1	42	45 (20)	3543PMURF
37.5	B1	45	46 (21)	37X43PMURF
40	B1	48	46 (21)	4043PMURF
42.5	B1	51	47 (21)	42X43PMURF
45	B1	54	47 (22)	4543PMURF
50	B1	60	48 (22)	5043PMURF
55	B1	66	48 (22)	5543PMURF
60	B1	72	48 (22)	6043PMURF
65	C1	78	64 (29)	6543PMURF
70	C1	84	65 (30)	7043PMURF
75	C1	90	65 (30)	7543PMURF
80	C1	96	66 (30)	8043PMURF
85	C1	102	68 (31)	8543PMURF
90	C1	108	68 (31)	9043PMURF
100	C1	120	68 (31)	10043PMURF
120	C1	144	68 (31)	12043PMURF
125	C2	150	99 (45)	12543PMURF
140	C2	168	100 (46)	14043PMURF
150	C2	180	101 (46)	15043PMURF
160	C2	192	103 (47)	16043PMURF
180	C2	216	104 (47)	18043PMURF

Notes

Fused with blown-fuse indication available standard.

Non-fused and no lights also available—please consult the factory.

Other ratings available, consult factory.

For dimensional information, refer to **Page 49**.

Part Number

PMURF—three fuses + three lights

PMURN—non-fused

10.4

SPD, Power Conditioning, PF Capacitors and Harmonic Filters

Power Factor Correction Capacitors

UNIPAK



480 Vac UNIPAK, continued

kVAR	Enclosure	Rated Current	Shipping Weight in Lbs (kg)	Part Number
200	D1	240	137 (62)	20043PMURF
225	D1	270	140 (64)	22543PMURF
250	E1	300	170 (77)	25043PMURF
300	E1	360	175 (80)	30043PMURF
350	E1	420	182 (83)	35043PMURF
400	E1	480	189 (86)	40043PMURF

Notes

Fused with blown-fuse indication available standard.

Non-fused and no lights also available—please consult the factory.

Other ratings available, consult factory.

For dimensional information, refer to **Page 49**.

Part Number

PMURF—three fuses + three lights

PMURN—non-fused

UNIPAK

600 Vac UNIPAK



kVAR	Enclosure	Rated Current	Shipping Weight in Lbs (kg)	Part Number
5	A1	4.9	19 (9)	563PMURF
7.5	A1	7.4	19 (9)	7X63PMURF
10	A1	9.8	20 (9)	1063PMURF
12.5	A1	12.3	20 (9)	12X63PMURF
15	A2	14.7	29 (13)	1563PMURF
17.5	A2	17.2	29 (13)	17X63PMURF
20	A2	19.6	30 (14)	2063PMURF
22.5	B1	22.1	44 (20)	22X63PMURF
25	A2	24.5	31 (14)	2563PMURF
27.5	B1	27.0	44 (20)	27X63PMURF
30	B1	29.4	45 (20)	3063PMURF
32.5	B1	31.9	45 (20)	32X63PMURF
35	B1	34.3	46 (21)	3563PMURF
37.5	B1	36.8	46 (21)	37X63PMURF
40	B1	39.2	47 (21)	4063PMURF
42.5	B1	41.7	47 (22)	42X63PMURF
45	B1	44.1	48 (22)	4563PMURF
50	B1	49.0	48 (22)	5063PMURF
55	C1	53.9	64 (29)	5563PMURF
60	C1	58.8	64 (29)	6063PMURF
65	C1	63.7	65 (30)	6563PMURF
70	C1	68.6	65 (30)	7063PMURF
75	C1	73.5	66 (30)	7563PMURF
80	C1	78.4	68 (31)	8063PMURF
85	C1	83.3	68 (31)	8563PMURF
90	C1	88.2	68 (31)	9063PMURF
100	C1	98.0	68 (31)	10063PMURF
120	C2	117.6	99 (45)	12063PMURF
125	C2	122.5	100 (46)	12563PMURF
140	C2	137.2	101 (46)	14063PMURF
150	C2	147.0	103 (47)	15063PMURF
160	D1	156.8	135 (61)	16063PMURF
180	D1	176.4	137 (62)	18063PMURF
200	D1	196.0	140 (64)	20063PMURF
225	D1	220.5	143 (65)	22563PMURF
250	E1	245.0	170 (77)	25063PMURF
300	E1	294.0	175 (80)	30063PMURF
350	E1	343.0	182 (83)	35063PMURF
400	E1	392.0	189 (86)	40063PMURF

Notes

Fused with blown-fuse indication available standard. Non-fused and no lights also available—please consult the factory

Other ratings available, consult factory

For dimensional information, refer to **Page 49**.

Part Numbers:

PMURF—three fuses + three lights

PMURN—non-fused

10.4

SPD, Power Conditioning, PF Capacitors and Harmonic Filters

Power Factor Correction Capacitors

UNIPAK—with Harmonic Cells

Harmonic Cells



Low Voltage Fixed Capacitor Systems with Harmonic Cells

kVAR	Rated Current	Case Size	Shipping Weight in Lbs (kg)	Catalog Number
240V				
15	36	B1	38.4 (17)	1523HURF
25	60	B1	38.4 (17)	2523HURF
30	72	C1	55.2 (25)	3023HURF
50	120	C1	57.6 (26)	5023HURF
60	144	C2	100.8 (46)	6023HURF
75	180	C2	104.4 (47)	7523HURF
100	240	D1	136.8 (62)	10023HURF
125	300	E1	189.6 (86)	12523HURF
480V				
15	18	A2	25.2 (11)	1543HURF
25	30	B1	37.2 (17)	2543HURF
30	36	B1	38.4 (17)	3043HURF
50	60	B1	39.6 (18)	5043HURF
60	72	C1	52.8 (24)	6043HURF
75	90	C1	55.2 (25)	7543HURF
100	120	C1	57.6 (26)	10043HURF
125	150	C2	100.8 (46)	12543HURF
150	180	C2	104.4 (47)	15043HURF
200	240	D1	136.8 (62)	20043HURF
250	300	E1	186.0 (84)	25043HURF
300	360	E1	189.6 (86)	30043HURF
600V				
15	14.7	B1	37.2 (17)	1563HURF
25	24.5	B1	38.4 (17)	2563HURF
30	29.4	B1	39.6 (18)	3063HURF
50	49	C1	55.2 (25)	5063HURF
60	58.8	C1	57.6 (26)	6063HURF
75	73.5	C2	100.8 (46)	7563HURF
100	98	C2	104.4 (47)	10063HURF
125	122.5	D1	136.8 (62)	12563HURF
150	147	D1	136.8 (62)	15063HURF
200	196	E1	186.0 (84)	20063HURF
250	245	E1	189.6 (86)	25063HURF

Notes

Fused with blown-fuse indication standard.
Other ratings available, consult factory.

UNIPAK Low Voltage Fixed Harmonic Filters

Harmonic Filters

**Fixed UNIPAK Harmonic Filters**

kVAR	Rated Current	Case Size	Shipping Weight in Lbs (kg)	Reactor Cabinet Case Size	Reactor Shipping Weight in Lbs (kg)	Combined Shipping Weight in Lbs (kg)	Catalog Number
240V							
15	36	B1	48.4 (22.0)	R	90.0 (40.9)	138.4 (62.8)	15232HMURF
25	60	B1	48.4 (22.0)	R	105.0 (47.7)	153.4 (69.6)	25232HMURF
30	72	C1	65.2 (29.6)	R	110.0 (49.9)	175.2 (79.5)	30232HMURF
50	120	C1	67.6 (30.7)	R	130.0 (59.0)	197.6 (89.7)	50232HMURF
60	144	C2	110.8 (50.3)	R	160.0 (72.6)	270.8 (122.9)	60232HMURF
75	180	C2	114.4 (51.9)	R	185.0 (84.0)	299.4 (135.9)	75232HMURF
100	240	D1	146.8 (66.6)	R	240.0 (109.0)	386.8 (175.6)	100232HMURF
125	300	E1	199.6 (90.6)	S	280.0 (127.1)	479.6 (217.7)	125232HMURF
150	360	E1	220.0 (99.9)	S	280.0 (127.1)	500.0 (227.0)	150232HMURF
480V							
15	18	A2	35.2 (16.0)	R	90.0 (40.9)	125.2 (56.8)	15432HMURF
25	30	B1	47.2 (21.4)	R	105.0 (47.7)	152.2 (69.1)	25432HMURF
30	36	B1	48.4 (22.0)	R	110.0 (49.9)	158.4 (71.9)	30432HMURF
50	60	B1	49.6 (22.5)	R	130.0 (59.0)	179.6 (81.5)	50432HMURF
60	72	C1	62.8 (28.5)	R	160.0 (72.6)	222.8 (101.2)	60432HMURF
75	90	C1	65.2 (29.6)	R	185.0 (84.0)	250.2 (113.6)	75432HMURF
100	120	C1	67.6 (30.7)	R	240.0 (109.0)	307.6 (139.7)	100432HMURF
125	150	C2	110.8 (50.3)	R	280.0 (127.1)	390.8 (177.4)	125432HMURF
150	180	C2	114.4 (51.9)	S	280.0 (127.1)	394.4 (179.1)	150432HMURF
200	240	D1	146.8 (66.6)	S	330.0 (149.8)	476.8 (216.5)	200432HMURF
250	300	E1	196.0 (89.0)	T	570.0 (258.8)	766.0 (347.8)	250432HMURF
300	360	E1	199.6 (90.6)	T	575.0 (261.1)	774.6 (351.7)	300432HMURF
600V							
15	14.7	B1	47.2 (21.4)	R	90.0 (40.9)	137.2 (62.3)	15632HMURF
25	24.5	B1	48.4 (22.0)	R	90.0 (47.7)	153.4 (69.6)	25632HMURF
30	29.4	B1	49.6 (22.5)	R	105.0 (49.9)	159.6 (72.5)	30632HMURF
50	49	C1	65.2 (29.6)	R	110.0 (59.0)	195.2 (88.6)	50632HMURF
60	58.8	C1	67.6 (30.7)	R	130.0 (72.6)	227.6 (103.3)	60632HMURF
75	73.5	C2	110.8 (50.3)	R	160.0 (84.0)	295.8 (134.3)	75632HMURF
100	98	C2	114.4 (51.9)	R	185.0 (109.0)	354.4 (160.9)	100632HMURF
125	122.5	D1	146.8 (66.6)	S	240.0 (127.1)	426.8 (193.8)	125632HMURF
150	147	D1	146.8 (66.6)	S	280.0 (127.1)	426.8 (193.8)	150632HMURF
200	196	E1	196.0 (89.0)	T	330.0 (149.8)	526.0 (238.8)	200632HMURF
250	245	E1	199.6 (90.6)	T	570.0 (258.8)	769.6 (349.4)	250632HMURF

Notes

Other ratings available, consult factory.

Fused with blown-fuse indication standard.

10.4

SPD, Power Conditioning, PF Capacitors and Harmonic Filters

Power Factor Correction Capacitors

Wiring Diagram

Filter Schematic with Wiring Interconnects

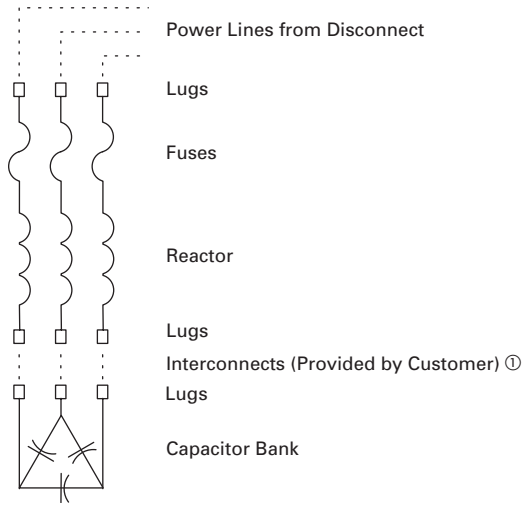

10

Note

① Refer to NEC.

Dimensions

Approximate Dimensions in Inches (mm)

Reactor Cabinet

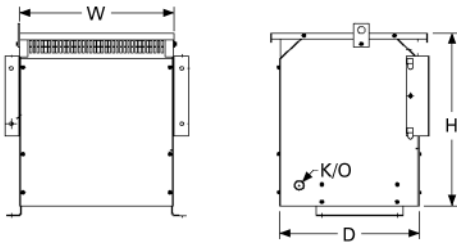

Reactor Cabinet

Case Size	Height	Width	Depth
R	24.75 (628.7)	20.00 (508.0)	18.13 (460.5)
S	25.00 (635.0)	24.25 (616.0)	20.25 (514.4)
T	31.00 (787.4)	25.00 (635.0)	32.75 (831.9)

Low Voltage Fixed Capacitor Banks and Fixed Harmonic Filters

Case A1, A2

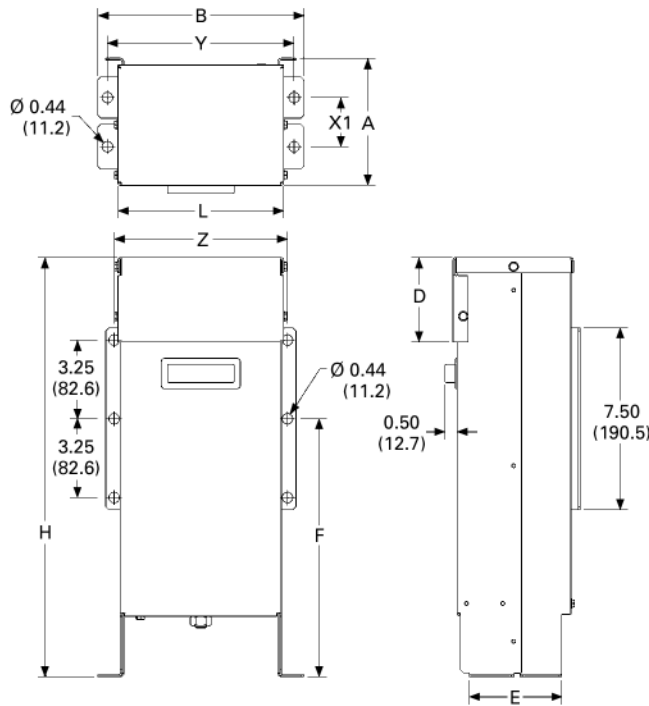

Case B1

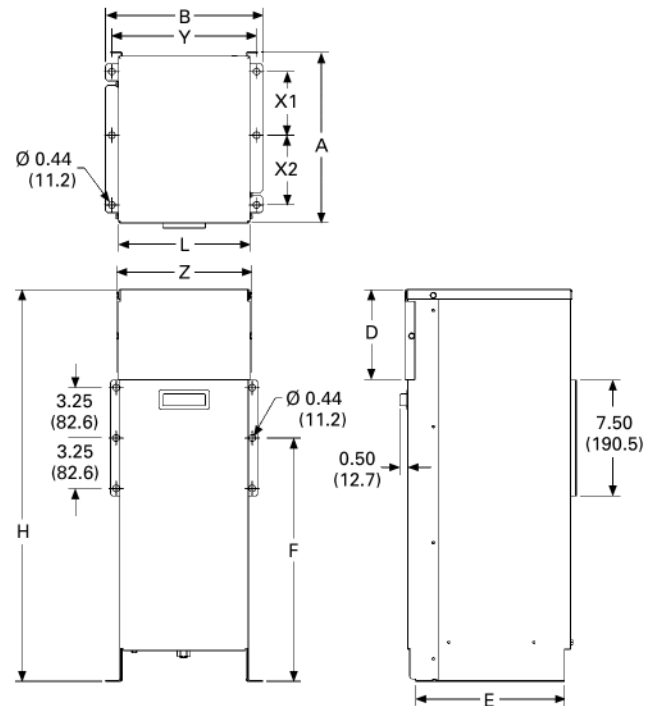

10

UNIPAK Enclosures

Case Size	A	B	D	E	F	H	L	X1	X2	X3	Y	Z
A1	5.30 (134.6)	8.50 (215.9)	3.50 (88.9)	3.80 (96.5)	10.60 (269.2)	17.30 (439.4)	6.80 (172.7)	2.00 (50.8)	N/A	N/A	7.70 (195.6)	7.20 (182.9)
A2	6.00 (152.4)	8.50 (215.9)	5.60 (142.2)	4.50 (114.3)	13.30 (337.8)	22.30 (566.4)	6.80 (172.7)	2.30 (58.4)	N/A	N/A	7.70 (195.6)	7.20 (182.9)
B1	11.10 (281.9)	10.10 (256.5)	5.80 (147.3)	9.60 (243.8)	15.70 (398.8)	25.30 (642.6)	8.50 (215.9)	4.10 (104.1)	4.50 (114.3)	N/A	9.30 (236.2)	8.80 (223.5)

Legend:

- A = Total depth
- B = Total width
- D = Height of removable front cover
- E = Depth of feet
- F = Height of middle mounting hole in wall bracket
- H = Total height
- L = Width without feet and brackets
- X = Depth between front and rear mounting holes in inches
- Y = Width between floor mounting holes
- Z = Width between wall bracket mounting holes

10.4

SPD, Power Conditioning, PF Capacitors and Harmonic Filters

Power Factor Correction Capacitors

Approximate Dimensions in Inches (mm)

Case C1, C2

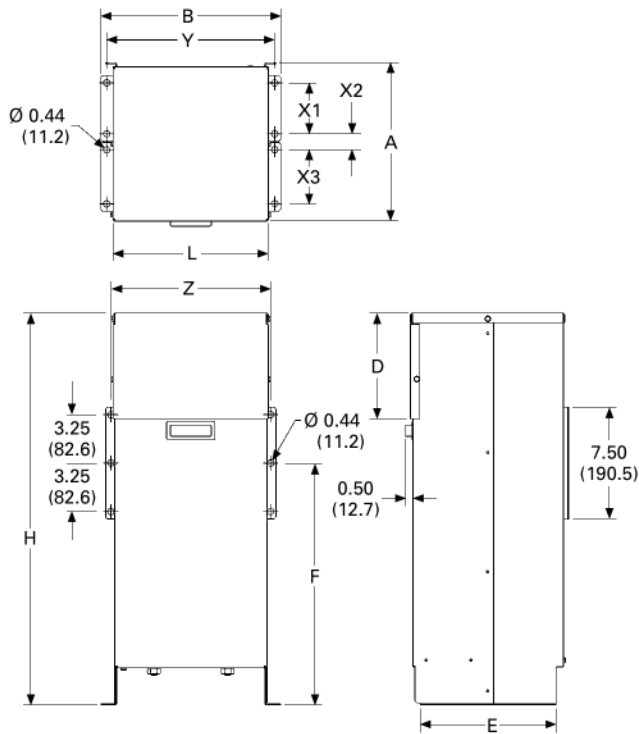

Case D1, E1

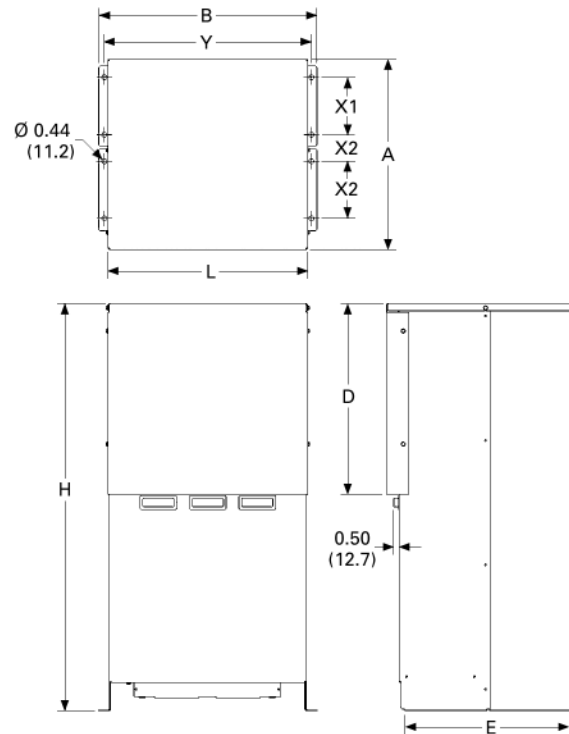

UNIPAK Enclosures

Case Size	A	B	D	E	F	H	L	X1	X2	X3	Y	Z
C1	10.60 (269.2)	12.10 (307.3)	7.10 (180.3)	9.10 (231.1)	16.20 (411.5)	26.30 (668.0)	10.40 (264.2)	3.40 (86.4)	1.10 (27.9)	3.60 (91.4)	11.30 (287.0)	10.70 (271.8)
C2	12.00 (304.8)	19.30 (490.2)	16.90 (429.3)	9.50 (241.3)	16.30 (414.0)	36.00 (914.4)	17.70 (449.6)	3.00 (76.2)	1.50 (38.1)	3.80 (96.5)	18.30 (464.8)	18.00 (457.2)
D1	16.80 (426.7)	19.30 (490.2)	16.90 (429.3)	14.60 (370.8)	N/A	36.00 (914.4)	17.70 (449.6)	5.10 (129.5)	2.40 (61.0)	5.00 (127.0)	18.30 (464.8)	N/A
E1	22.30 (566.4)	24.40 (619.8)	16.80 (426.7)	19.50 (495.3)	N/A	36.00 (914.4)	22.70 (576.6)	6.50 (165.1)	4.40 (111.8)	5.00 (127.0)	22.40 (569.0)	N/A

Legend:

- A = Total depth
- B = Total width
- D = Height of removable front cover
- E = Depth of feet
- F = Height of middle mounting hole in wall bracket
- H = Total height
- L = Width without feet and brackets
- X = Depth between front and rear mounting holes in inches
- Y = Width between floor mounting holes
- Z = Width between wall bracket mounting holes

AUTOVAR 300



Contents

<i>Description</i>	<i>Page</i>
Product Overview	34
UNIPUMP	37
UNIPAK	40
AUTOVAR 300 Automatic Power Factor Correction Capacitor Systems	
Product Selection	52
Options	52
Dimensions	53
AUTOVAR 600 Automatic Power Factor Correction Capacitor Systems	54
AUTOVAR Filter—LV Automatic Harmonic Filter	59
Transient-Free Static Switching Power Factor Correction Units	63
Active-Harmonic Filter-Harmonic Correction Unit—NEMA 1 Enclosure	67

AUTOVAR 300 Automatic Power Factor Correction Capacitor Systems

Product Description

Automatically switched power factor correction systems for low voltage applications.

- Wallmount design is ideal for minimum space requirements
- Programmable to automatically add/subtract capacitor banks to maintain preset target power factor
- Heavy-duty, three-phase capacitor construction
- Five-year warranty of cells

Application Description

Service entrance power factor correction installations requiring precise maintenance of target power factor in a very small footprint.

Features

Configuration

- **Cabinet:** Wall mounting 12 gauge steel with ANSI 61 gray, NEMA 1 (gasketed)
- **Power line interconnect:** Rugged, power distribution block connection
- **Fusing:** 200,000 ampere interrupting capacity provided on all three phases of each bank. Blade-type fuses mounted on insulator stand-offs with blown-fuse indicating lights
- **Blown-fuse lights:** Blown-fuse indicating lights for each phase and stage located on the door
- **Door interlock:** Door interlock automatically disengages capacitors. Power continues to be provided to the unit until the disconnect is open
- **Exhaust fans:** Provide ventilation. Dust filtering included

Controller

- Digital display of power factor and number of energized banks
- Visual indication of insufficient kVAR to reach target power factor
- LCD backlight display
- Capacitors disabled in steps within 35 ms of main power interruption
- Harmonic measurement up to 19 harmonic and alarm (THDV)
- Automatic detection and correction of CT and phase polarity
- Automatic detection of connected steps
- Maximum 14 output steps
- Provides protection against overvoltage, overtemperature and harmonic overload events
- Advanced control features available
- Optional communications capability (C option controller)
- Standard metering capability
 - Voltage
 - Current (sensed phase only)
 - Frequency
 - Active power (kW)
 - Reactive power (kVAR)
 - Apparent power (kVA)

Contactor

- Fully rated for capacitor switching up to 60 kVAR at 600V
- Integral pre-charge/pre-insertion module standard. The contactor reduces damaging switching transients. This provides safety and durability for the system:
 - Lessens the chance of disrupting sensitive electronic equipment
 - Reduced inrush current extends the life of the capacitor cells

Additional Features

- Optional molded case circuit breaker rated 65 kAIC at 480V and 600V
- Personnel ground fault interruption provides protection in case of accidental contact with control power and ground
- NEMA 3R weatherproofing

Standards and Certifications

- UL/CSA listed and recognized



Product Selection

Wallmounted Switched Capacitor Bank



Wallmounted Switched Capacitor Banks—Low Voltage Applications ①

kVAR	Step x kVAR	Rated Current Amperes	Case Size ②	Shipping Weight in Lbs (kg)	Catalog Number
240 Volt					
25	5 x 5	60	J	217 (98.5)	25MCSR2313
50	5 x 10	120	J	255 (115.8)	50MCSR2313
75	5 x 15	180	J	260 (118.0)	75MCSR2313
100	5 x 20	240	J	270 (122.6)	100MCSR231
125	5 x 25	300	J	292 (132.6)	125MCSR231
150	5 x 30	361	J	314 (142.6)	150MCSR231
480 Volt					
50	5 x 10	60	J	200 (90.8)	50MCSR4313
75	5 x 15	90	J	210 (95.3)	75MCSR4313
100	5 x 20	120	J	210 (95.3)	100MCSR4313
125	5 x 25	150	J	240 (109.0)	125MCSR4313
150	5 x 30	180	J	240 (109.0)	150MCSR4313
175	5 x 35	210	J	260 (118.0)	175MCSR431
200	5 x 40	241	J	270 (122.6)	200MCSR431
225	5 x 45	270	J	290 (131.7)	225MCSR431
250	5 x 50	300	J	292 (132.6)	250MCSR431
300	5 x 60	361	J	310 (140.7)	300MCSR431
600 Volt					
50	5 x 10	48	J	200 (90.8)	50MCSR6313
75	5 x 15	72	J	210 (95.3)	75MCSR6313
100	5 x 20	96	J	210 (95.3)	100MCSR6313
125	5 x 25	120	J	240 (109.0)	125MCSR6313
150	5 x 30	144	J	240 (109.0)	150MCSR6313
175	5 x 35	168	J	260 (118.0)	175MCSR631
200	5 x 40	192	J	270 (122.6)	200MCSR631
225	5 x 45	216	J	290 (131.7)	225MCSR631
250	5 x 50	240	J	292 (132.6)	250MCSR631
300	5 x 60	288	J	310 (140.7)	300MCSR631

Options

Description	Option Code
Current transformer—multi-tap, split core current transformer (3000:5A) ③	TX2
Hands-off auto switch—provides manual control to connect or disconnect capacitor stages regardless of controller output	H
Remote alarm relay—relay for a remote alarm to indicate inability to reach target power factor	A
Molded case circuit breaker (65 kAIC at 480V)	M
Weatherproofing (NEMA 3R)	W
Communicating controller	C

Notes

- ① Other ratings available, please consult factory.
 ② For dimensional information, refer to **Page 53**.
 ③ A current transformer with a 5 ampere secondary is required to operate an automatic capacitor bank. Rating based on service entrance ampacity. For other ratios, please consult factory.

Dimensions

Approximate Dimensions in Inches (mm)

Enclosure J

Front View

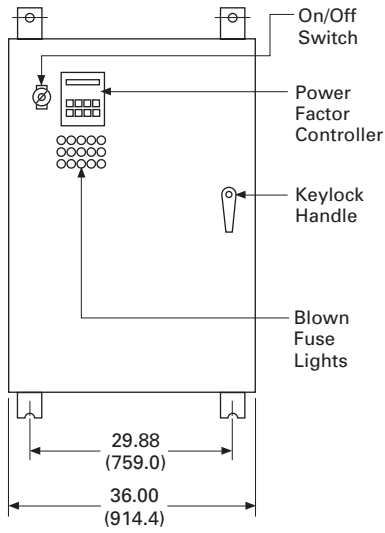

Side View

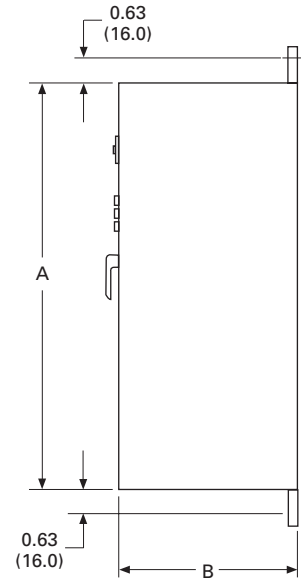

Enclosure J

Description	Height A	Depth B
Without MCCB	36.00 (914.4)	14.00 (355.6)
With MCCB	60.00 (1524.0)	14.00 (355.6)

AUTOVAR 600



10

Contents

<i>Description</i>	<i>Page</i>
Product Overview	34
UNIPUMP	37
UNIPAK	40
AUTOVAR 300 Automatic Power Factor Correction Capacitor Systems	51
AUTOVAR 600 Automatic Power Factor Correction Capacitor Systems	
Standards and Certifications	55
Product Selection	56
Options	57
Dimensions	58
AUTOVAR Filter—LV Automatic Harmonic Filter	59
Transient-Free Static Switching Power Factor Correction Units	63
Active-Harmonic Filter-Harmonic Correction Unit—NEMA 1 Enclosure	67

AUTOVAR 600 Automatic Power Factor Correction Capacitor Systems

Product Description

Programmable to automatically add/subtract capacitor banks to maintain preset target power factor.

Application Description

Service entrance power factor correction installations requiring precise maintenance of target power factor.

Features

- Heavy-duty, three-phase capacitor construction
- Five-year warranty of cells

Configuration

- **Cabinet:** 12 gauge steel with ANSI 61 gray, powder coat finish. Lift bolts standard, NEMA 1
- **Power line interconnect:** Rugged, copper bus bar connection with access provided for top or bottom entry. Bus bars are braced for 65 kAIC at 480V. All internal power wiring connections from bus are laid out on a most direct basis with minimum bends for ease of troubleshooting. Clear barrier limiting access to live parts included standard
- **Modular tray design:** Capacitor banks arranged in modular trays with capacitors, fuses, blown-fuse indicating lights, and contactors grouped in a logical, easily understood layout. This permits easy access, quick identification of operating problems and ease of expandability
- **Fusing:** UL recognized, 200,000 ampere interrupting capacity provided on all three phases of each bank. Blade-type fuses mounted on insulator stand-offs
- **Blown-fuse lights:** Blown-fuse indicating lights located on the door-mounted blown and at individual fuses to facilitate tracing of cleared fuses
- **Push-to-test:** Allows testing of door-mounted blown fuse indicating lights
- **AutoLocate:** When door is open and bus energized, fuse circuit automatically checks for cleared fuses. If a fuse has cleared, the light at the fuse comes on for easy troubleshooting
- **Door interlock:** Door interlock automatically turns off control circuit when engaged. Power continues to be provided to the unit until disconnect is open

- **Exhaust fans:** Two fans per cabinet provide thermal protection. Dust filtering provided
- **Ease of expansion:** Capacitor stage nests are self-contained and can be added in the field. Two bolts mount the nest in the field. Control wire plugs connect to factory standard wire harness on the left side of the cabinet
- **Ease of replacement:** Cells can be easily individually replaced by removing the mounting bolt and lifting out of the nest without removal of any other components

Controller

- Digital display of power factor and number of energized banks
- Visual indication of insufficient kVAR to reach target power factor
- LCD backlight display
- Capacitors disabled in steps within 35 ms of main power interruption
- Harmonic measurement up to 19 harmonic and alarm (THDV)
- Automatic detection and correction of CT and phase polarity
- Automatic detection of connected steps
- Maximum 14 output steps
- Provides protection against overvoltage, overtemperature and harmonic overload events
- Advanced control features available
- Optional communications capability (C option controller)
- Standard metering capability
 - Voltage
 - Current (sensed phase only)
 - Frequency
 - Active power (kW)
 - Reactive power (kVAR)
 - Apparent power (kVA)

Contactors

- Fully rated for capacitor switching up to 60 kVAR at 600V
- Integral pre-charge/pre-insertion module standard. The contactor reduces damaging switching transients. This provides safety and durability for the system:
 - Lessens the chance of disrupting sensitive electronic equipment
 - Reduced inrush current extends the life of the capacitor cells

Additional Features

- Optional molded case circuit breaker, rated 65 kAIC at 48V and 600V
- Personnel ground fault interruption provides protection in case of accidental contact with control power and ground
- Control wiring—standard NEC color-coded modular bundles with quick disconnect feature for ease of troubleshooting or ease of expendability
- Optional digital metering

**AUTOVAR 600—Interior View****Bottom Entry Location****Modular Step Nest Assembly****Factory Pre-Wired for Future Expansion****Standards and Certifications**

- UL/CSA listed and recognized



Listed

10.4

SPD, Power Conditioning, PF Capacitors and Harmonic Filters

Power Factor Correction Capacitors

Product Selection

Floor-Mounted Switched Capacitor Banks—Low Voltage Applications

Floor-Mounted Switched Capacitor Bank



240 Vac

kVAR	Step x kVAR	Rated Current Amperes	Enclosure Size	Shipping Weight in Lbs (kg)	Catalog Number
75	3 x 25	180	L	644 (292.4)	75TPCSR231
100	4 x 25	214	L	692 (314.2)	100TPCSR231
125	5 x 25	300	L	740 (336.0)	125TPCSR231
150	6 x 25	316	L	788 (357.8)	150TPCSR231
200	8 x 25	481	L	884 (401.3)	200TPCSR231
250	10 x 25	600	L	944 (428.6)	250TPCSR231
300	12 x 25	720	L	1022 (464.0)	300TPCSR231
350	7 x 50	844	KK	1616 (734.0)	350TPCSR231
400	8 x 50	965	KK	1704 (774.0)	400TPCSR231

480 Vac

kVAR	Step x kVAR	Rated Current Amperes	Enclosure Size	Shipping Weight in Lbs (kg)	Catalog Number
150	3 x 50	180	L	632 (287.0)	150TPCSR431
200	4 x 50	240	L	676 (306.9)	200TPCSR431
250	5 x 50	300	L	720 (326.9)	250TPCSR431
300	6 x 50	360	L	764 (346.9)	300TPCSR431
350	7 x 50	420	L	808 (366.8)	350TPCSR431
400	8 x 50	480	L	852 (386.8)	400TPCSR431
450	9 x 50	540	L	896 (406.8)	450TPCSR431
500	10 x 50	600	L	944 (428.6)	500TPCSR431
550	11 x 50	660	L	984 (446.7)	550TPCSR431
600	12 x 50	720	L	1022 (464.0)	600TPCSR431
660	11 x 60	792	L	1010 (458.5)	660TPCSR431
700	7 x 100	840	L	1616 (734.0)	700TPCSR431
720	12 x 60	864	L	1050 (476.7)	720TPCSR431
800	8 x 100	960	KK	1704 (774.0)	800TPCSR431
840	14 x 60	1008	L	1690 (767.7)	840TPCSR431
900	9 x 100	1080	KK	1792 (814.0)	900TPCSR431
1000	10 x 100	1200	KK	1888 (857.0)	1000TPCSR431
1100	11 x 100	1320	KK	1966 (893.0)	1100TPCSR431
1200	12 x 100	1440	KK	2044 (928.0)	1200TPCSR431

Notes

Other ratings and step configurations available, please consult factory.
For dimensional information, refer to **Page 58**.

Floor-Mounted
Capacitor Bank

600 Vac

kVAR	Step x kVAR	Rated Current Amperes ^①	Enclosure Size	Shipping Weight in Lbs (kg)	Catalog Number
150	3 x 50	144	L	632 (287.0)	150TPCSR631
200	4 x 50	192	L	676 (306.9)	200TPCSR631
250	5 x 50	240	L	720 (326.9)	250TPCSR631
300	6 x 50	288	L	764 (346.9)	300TPCSR631
350	7 x 50	336	L	808 (366.8)	350TPCSR631
400	8 x 50	384	L	852 (386.8)	400TPCSR631
450	9 x 50	432	L	896 (406.8)	450TPCSR631
500	10 x 50	480	L	944 (428.6)	500TPCSR631
550	11 x 60	528	L	984 (446.7)	550TPCSR631
600	12 x 50	576	L	1022 (464.0)	600TPCSR631
660	11 x 60	634	L	1010 (458.5)	660TPCSR631
700	7 x 100	672	L	1616 (734.0)	700TPCSR631
720	12 x 60	692	L	1050 (476.7)	720TPCSR631
800	8 x 100	768	KK	1704 (774.0)	800TPCSR631
840	14 x 60	1008	L	1690 (767.7)	840TPCSR631
900	9 x 100	864	KK	1792 (814.0)	900TPCSR631
1000	10 x 100	960	KK	1888 (857.0)	1000TPCSR631
1100	11 x 100	1056	KK	1966 (893.0)	1100TPCSR631
1200	12 x 100	1152	KK	2044 (928.0)	1200TPCSR631

Options

Description	Option Code
Current transformer—multi-tap, split core current transformer (3000:5A) ^②	TX2
Hands-off auto switch—provides manual control to connect or disconnect capacitor stages regardless of controller output	H
Remote alarm relay—relay for a remote alarm to indicate inability to reach target power factor	A
Molded case circuit breaker (65 kAIC at 480V)	M
Weatherproofing (NEMA 3R)	W
Communicating controller	C
IQ 250 solid-state meter ^③	Q

Notes

- ^① Other ratings and step sizes available, please consult factory.
^② A current transformer with a 5 ampere secondary is required to operate an automatic capacitor bank. Rating based on service entrance ampacity. For other ratios, please consult factory.
^③ Not available with weatherproofing option.

For dimensional information, refer to **Page 58**.

10.4

SPD, Power Conditioning, PF Capacitors and Harmonic Filters

Power Factor Correction Capacitors

Dimensions

Approximate Dimensions in Inches (mm)

Enclosure L Front View

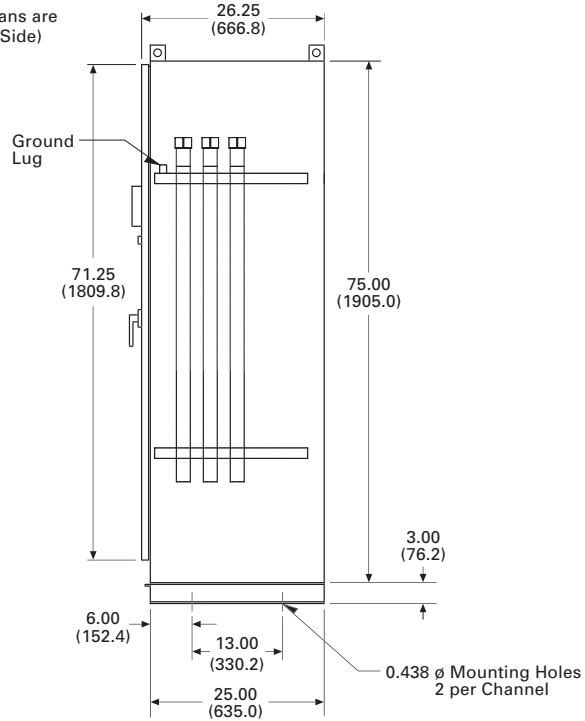
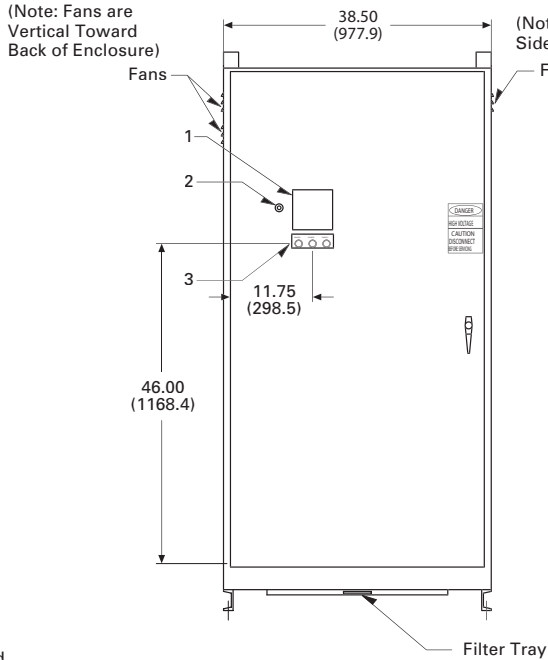

- Legend
1. Controller
 2. On/Off Switch
 3. Blown Fuse Indicator Lights

Enclosure KK Front and Side Views

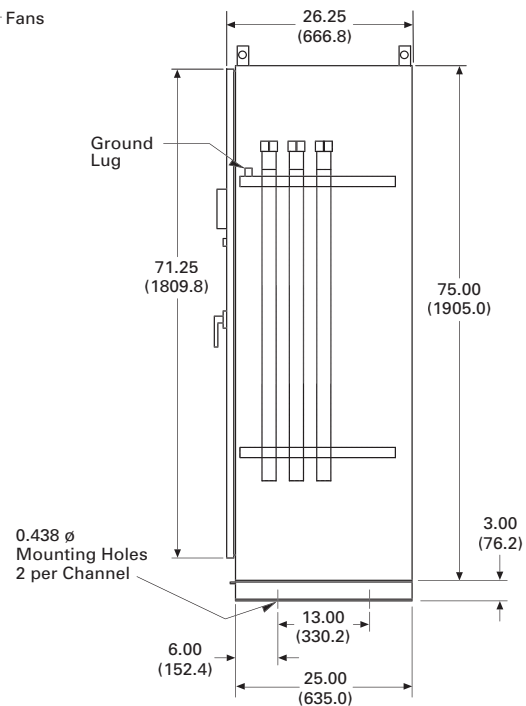
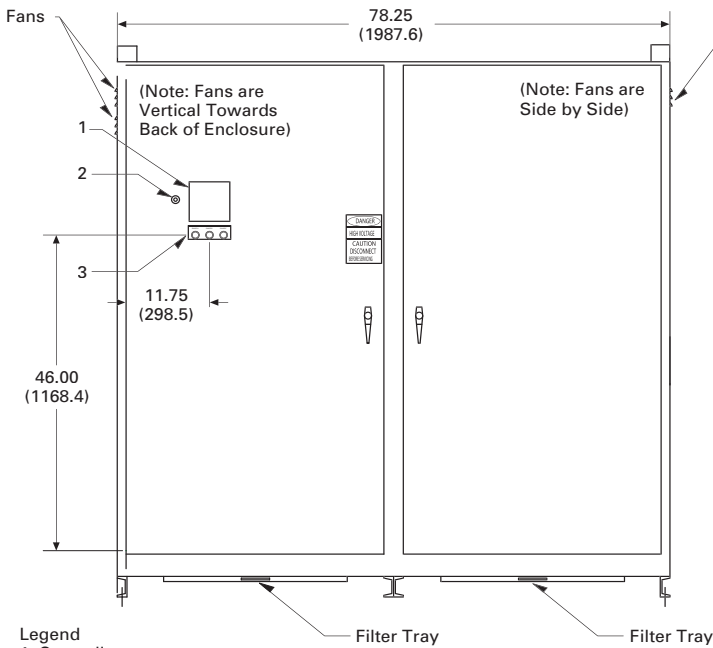

- Legend
1. Controller
 2. On/Off Switch
 3. Blown Fuse Indicating Light

AUTOVAR Filter



Contents

<i>Description</i>	<i>Page</i>
Product Overview	34
UNIPUMP	37
UNIPAK	40
AUTOVAR 300 Automatic Power Factor Correction Capacitor Systems	51
AUTOVAR 600 Automatic Power Factor Correction Capacitor Systems	54
AUTOVAR Filter—LV Automatic Harmonic Filter	
Standards and Certifications	60
Product Selection	61
Options	61
Dimensions	62
Transient-Free Static Switching Power Factor Correction Units	63
Active-Harmonic Filter—Harmonic Correction Unit—NEMA 1 Enclosure	67

AUTOVAR Filter—LV Automatic Harmonic Filter

Product Description

Automatically switched harmonic filter/ power factor corrections systems.

- Programmable to automatically add/subtract filter banks to maintain preset target power factor
- Filter steps tuned for maximum efficiency in reducing harmonic currents in three-phase environments with heavy nonlinear loads

Application Description

Service entrance power factor correction installations requiring precise maintenance of target power factor in three-phase, nonlinear, high harmonic environments.

Features

- Efficient modular design for short lead-times, ease of maintenance and ease of future expansion
- Heavy-duty, three-phase capacitor construction with reliable, threaded terminal connections
- Cool operating, 100% copper wound, thermal protected reactors are sized up to 150% of rated capacitor current

Configuration

- **Operation:** AUTOVAR harmonic filters are designed to be sized the same as any power factor correction unit. In most low voltage applications where harmonics are generated by nonlinear loads, no harmonic audit is necessary to design the AUTOVAR filter because it is already designed for typical harmonic spectrums at the kVAR size specified
- **Cabinet:** 12 gauge steel with ANSI 61 gray, powder coat finish. Lift bolts standard, NEMA 1

- **Power line interconnect:** Rugged, copper bus bar connection with access provided for top or bottom entry. Bus bars are braced for 65 kAIC at 480V. All internal power wiring connections from bus are laid out on a most direct basis with minimum bends for ease of troubleshooting. Clear barrier limiting access to live parts included standard
- **Modular tray design:** Capacitor banks arranged in modular trays with capacitors, fuses, blown-fuse indicating lights, and contactors grouped in a logical, easily understood layout. This permits easy access, quick identification of operating problems and ease of expandability
- **Fusing:** UL recognized, 200,000 ampere interrupting capacity provided on all three phases of each bank. Blade-type fuses mounted on insulator stand-offs
- **Blown-fuse lights:** Blown-fuse indicating lights located on the door-mounted blown and at individual fuses to facilitate tracing of cleared fuses
- **Push-to-test:** Allows testing of door-mounted blown fuse indicating lights.
- **AutoLocate:** When door is open and bus energized, fuse circuit automatically checks for cleared fuses. If a fuse has cleared, the light at the fuse comes on for easy troubleshooting
- **Door interlock:** Door interlock automatically turns off control circuit when engaged. Power continues to be provided to the unit until disconnect is open
- **Exhaust fans:** Two fans per cabinet provide thermal protection. Dust filtering provided
- **Ease of expansion:** Capacitor stage nests are self-contained and can be added in the field. Control wire plugs connect to factory standard wire harness on the left side of the cabinet
- **Ease of replacement:** Cells can be easily individually replaced by removing the mounting bolt and lifting out of the nest without removal of any other components

10.4

SPD, Power Conditioning, PF Capacitors and Harmonic Filters

Power Factor Correction Capacitors

Controller

- Digital display of power factor and number of energized banks
- Visual indication of insufficient kVAR to reach target power factor
- LCD backlight display
- Capacitors disabled in steps within 35 ms of main power interruption
- Harmonic measurement up to 19 harmonic and alarm (THDV)
- Automatic detection and correction of CT and phase polarity
- Automatic detection of connected steps
- Maximum 14 output steps
- Provides protection against overvoltage, overtemperature and harmonic overload events
- Advanced control features available
- Optional communications capability (C option controller)
- Standard metering capability
 - Voltage
 - Current (sensed phase only)
 - Frequency
 - Active power (kW)
 - Reactive power (kVAR)
 - Apparent power (kVA)

Contactors

- Fully rated for capacitor switching up to 60 kVAR at 600V
- Integral pre-charge/pre-insertion module standard. The contactor reduces damaging switching transients. This provides safety and durability for the system:
 - Lessens the chance of disrupting sensitive electronic equipment
 - Reduced inrush current extends the life of the capacitor cells

Reactors

- **Tuning:** Reactors tuned to the 4.7th harmonic order (nominal 5th). This provides maximum effectiveness in reducing harmonic currents in three-phase systems with harmonics caused by six-pulse devices
- **Detuning:** Reactor designs can be detuned upon request to 4.2nd to protect capacitors against alternate harmonics
- **Windings:** 100% copper windings for minimal temperature rise under load
- **Thermal overload protection:** Each reactor includes three normally closed, auto reset thermostats that open at 180°C. When thermostats engage, the contactor opens
- **Insulation:** 220°C insulation system
- **Warranty:** One-year replacement of reactors

Additional Features

- Optional molded case circuit breaker rated 65 kAIC at 480V and 600V
- Personnel ground fault interruption provides protection in case of accidental contact with control power and ground
- Control wiring—standard NEC color-coded modular bundles with quick disconnect feature for ease of troubleshooting or ease of expendability

Standards and Certifications

- UL/CSA listed and recognized



AUTOVAR Filter—Reactor Cabinet

Product Selection

Low Voltage Switched Harmonic Filters

Floor-Mounted
Switched Harmonic
Filter

Floor-Mounted Switched Harmonic Filters—Low Voltage

kVAR	Step x kVAR	Rated Current Amperes ^②	Enclosure Size ^{③④}	Shipping Weight in Lbs (kg)	Catalog Number
480 Vac					
200	4 x 50	240	L	1438 (652.9)	200THFSR431
250 ^①	5 x 50	300	L	1634 (741.8)	250THFSR431
300	6 x 50	360	KK or L + L	1830 (830.8)	300THFSR432
350	7 x 50	420	KK or L + L	2026 (919.8)	350THFSR432
400	8 x 50	480	KK or L + L	2222 (1008.8)	400THFSR432
450	9 x 50	540	KK or L + L	2371 (1076.4)	450THFSR432
500	10 x 50	600	KK or L + L	2525 (1146.4)	500THFSR432
550 ^①	11 x 50	660	KK or L + L	2750 (1248.5)	550THFSR432
600 ^①	12 x 50	720	KK or L + L	2830 (1284.8)	600THFSR432
600 Vac					
300	6 x 50	288	KK or L + L	1830 (830.8)	300THFSR632
350	7 x 50	336	KK or L + L	2026 (919.8)	350THFSR632
400	8 x 50	384	KK or L + L	2222 (1008.8)	400THFSR632
450	9 x 50	432	KK or L + L	2371 (1076.4)	450THFSR632
500	10 x 50	480	KK or L + L	2525 (1146.4)	500THFSR632
550 ^①	11 x 50	528	KK or L + L	2750 (1248.5)	550THFSR632
600 ^①	12 x 50	576	KK or L + L	2830 (1284.8)	600THFSR632

Options

Description	Option Code
Current transformer—multi-tap, split core current transformer ^⑤	TX2
Hands-off auto switch—provides manual control to connect or disconnect capacitor stages regardless of controller output	H
Remote alarm relay—relay for a remote alarm to indicate inability to reach target power factor	A
Molded case circuit breaker (65 kAIC at 480V)	M
Weatherproofing (NEMA 3R)	W
Communicating controller	C
IQ 250 solid-state meter ^⑥	Q

Notes

^① Enclosures for 550 and 600 kVAR at 480 and 600V will be one double-door section wide if circuit breakers are required (enclosure size KK). Enclosure for 250 kVAR at 480V will be one double-door section wide if a circuit breaker is required.

^② Other ratings available, please consult factory.

^③ L + L under enclosure size denotes two size L enclosures—one for the capacitors, one for the reactor case.

^④ For KK enclosure design, change the last digit of the catalog number to 1. For example, 500THFSR431.

^⑤ A current transformer with a 5 ampere secondary is required to operate an automatic capacitor bank. Rating based on service entrance ampacity. For other ratios, please consult factory.

^⑥ Not available with weatherproofing option.

For dimensional information, refer to **Page 62**.

10.4

SPD, Power Conditioning, PF Capacitors and Harmonic Filters

Power Factor Correction Capacitors

Dimensions

Approximate Dimensions in Inches (mm)

Enclosures L + L Front and Side Views

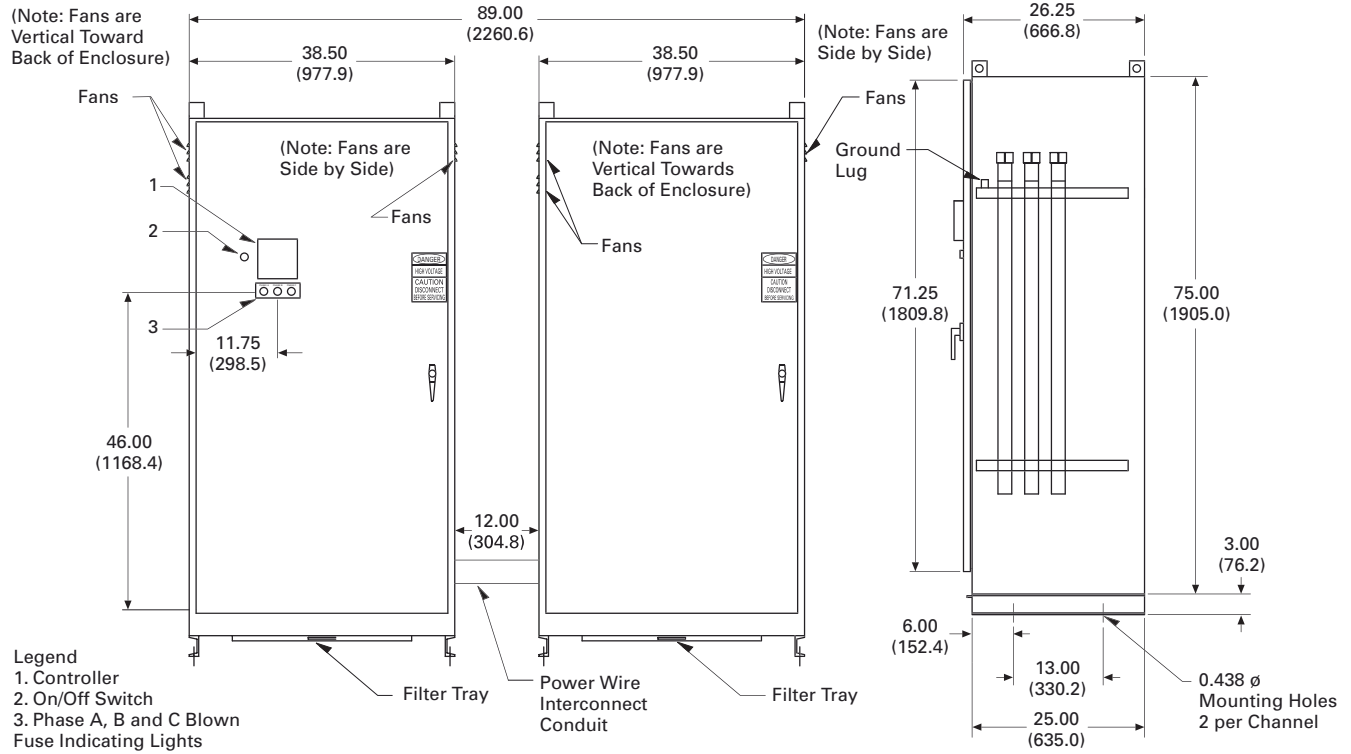

Transient-Free Power Factor Correction System



Contents

<i>Description</i>	<i>Page</i>
Product Overview	34
UNIPUMP	37
UNIPAK	40
AUTOVAR 300 Automatic Power Factor Correction Capacitor Systems	51
AUTOVAR 600 Automatic Power Factor Correction Capacitor Systems	54
AUTOVAR Filter—LV Automatic Harmonic Filter	59
Transient-Free Static Switching Power Factor Correction Units	
Features, Benefits and Functions	64
Standards and Certifications	64
Catalog Number Selection	65
Technical Data and Specifications	65
Dimensions	66
Active-Harmonic Filter-Harmonic Correction Unit—NEMA 1 Enclosure	67

Transient-Free Static Switching Power Factor Correction Units

Product Description

Transient-free statically switch capacitor units are available in two models.

The FTE model is a real-time transient-free system, used to compensate extremely rapid loads within one cycle of operation (typically 5–20 msec).

The FTA model is a fast transient-free system, used to compensate any loads within 3–4 seconds.

The FTA and FTE units employ a fast or real-time response, and include the ability to switch larger steps without creating significant line noise. These relatively maintenance-free units reside in a smaller footprint and are ideal for use in applications such as flicker control, large motor starting, bus voltage stabilization, fault ride through solutions, power factor correction and many more.

Application Description

- Motor starting
- On-site generation support
- Spot welding
- Wind turbines
- Other dynamic loads

Three current transformers with a 5 ampere secondary are required to operate this capacitor bank.

Rating based on Service Entrance Ampacity. For other ratios, please consult factory.

- Startup and Commissioning by factory trained personnel is required for proper operation and warranty of this system

Application Example—Spot Welding

Spot Welding (Auto Manufacturer)

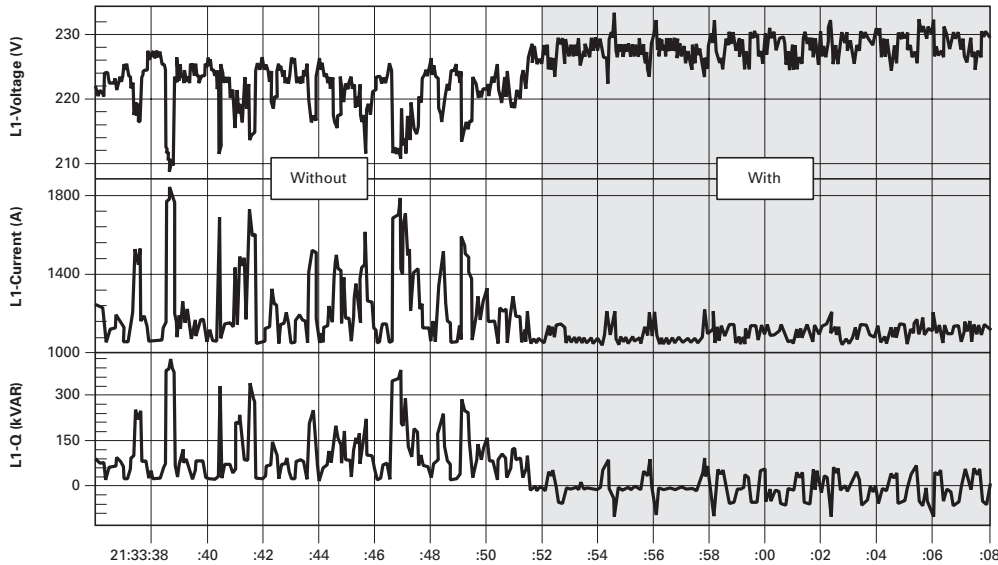

10

Features, Benefits and Functions

- Transient-free capacitor group switching, using electronic switching elements
 - Simultaneous connection/disconnection of all required steps
 - Consistent capacitor values and stable filter characteristics
 - Harmonic filtration
 - Three independent control modes:
 - Power factor control
 - Voltage control
 - Load sharing with another compensation system connected to the same transformer
 - Unique SCAN feature reduces capacitor duty cycles
 - Remote control of compensation systems available via LAN or Ethernet
 - Integrated three-phase network analyzer:
 - Measures all power parameters on each phase (V, I, kW, kVAR, kVA)
 - Measures voltage and current harmonics to the 63rd harmonic
- FTE unit includes all of the above, plus:
- Reduces voltage flicker and voltage sag
 - Provides network reactive power support
 - Offers voltage control options

Standards and Certifications

Enclosure

- EMC—EN50081-2, EN50082-2, EN55011, EN61000-4-2/3/4/5, ENV50204, ENV50141
- CE Mark—73/23/EEC am. 93/68, 98/37/EC art. 4(2)
- Safety—EN61010-1, EN60439-1, EN60204
- UL 508
- CSA



Catalog Number Selection

TFSS

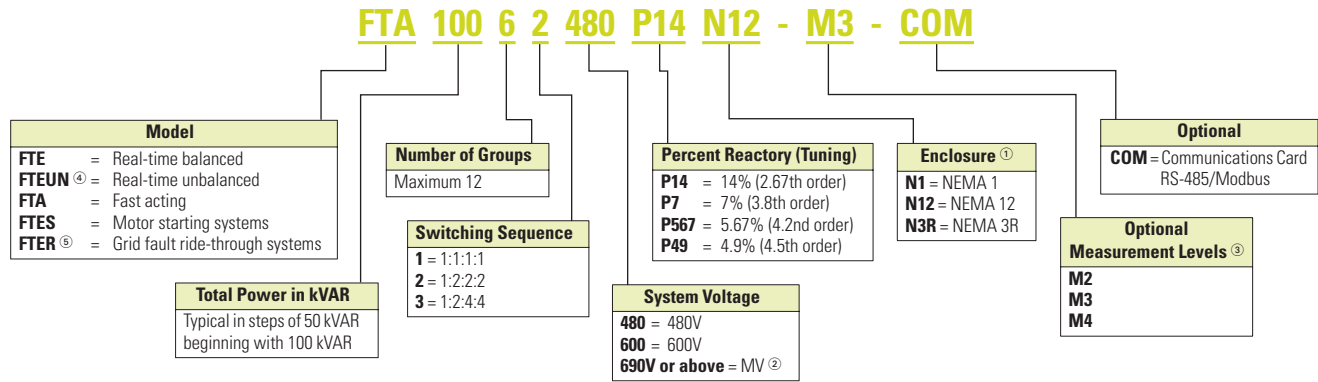

Technical Data and Specifications

Product Configurations

Network voltage

- 210–690V
- Engineered solutions up to 15 kV

Frequency

- 45–55 Hz for 50 Hz network
- 55–65 Hz for 60 Hz network

Capacitor group configurations

- Up to 12 groups per one controller
- Switching sequence:
 - 1:1:1:1 (all equal)
 - 1:2:2:2 (half group)
 - 1:2:4:4 (quarter, half groups)

Acquisition time

- FTE—5–20 ms for a 50 Hz network
- FTE—4–16 ms for a 60 Hz network
- FTA—1–4 second maximum

Notes

- ① All models are CE approved. Please notify if UL or cUL is required.
- ② MV units require:
A correctly sized and specified step-up transformer
MV and LV interconnection, switching and protection
- ③ All systems are offered with Measurement Level 1 (f, I, V, kW, kVAR, kVA, PF) and no communications card. The measurement levels can be upgraded to Measurement Level 2 (adds THD I and THDV), Measurement Level 3 (adds waveforms, I and V harmonics) and Measurement Level 4 (adds event log).
- ④ Balanced system employs two-phase switching, unbalanced system employs individual three-phase switching.
- ⑤ For motor start and grid fault ride-through solutions, please consult factory.

10.4

SPD, Power Conditioning, PF Capacitors and Harmonic Filters

Power Factor Correction Capacitors

Dimensions

Approximate Dimensions in Inches (mm)

Transient-Free Reactive Power Compensation Systems— Real-Time Transient-Free Systems—480 Vac

Compensate Rapid Loads Within One Cycle (Typically 5–20 ms)—Standard 6% Inductors— Detuned to 245 Hz (4.08th Harmonic)

Catalog Number	Width	Depth	Height
FTE15652480	31.50 (800.1)	23.60 (599.4)	82.70 (2100.6)
FTE18752480	31.50 (800.1)	23.60 (599.4)	82.70 (2100.6)
FTE21974480	31.50 (800.1)	23.60 (599.4)	82.70 (2100.6)
FTE25052480	31.50 (800.1)	23.60 (599.4)	82.70 (2100.6)
FTE26274480	31.50 (800.1)	23.60 (599.4)	82.70 (2100.6)
FTE31252480	31.50 (800.1)	23.60 (599.4)	82.70 (2100.6)
FTE37552480	31.50 (800.1)	23.60 (599.4)	82.70 (2100.6)
FTE43774480	31.50 (800.1)	23.60 (599.4)	82.70 (2100.6)
FTE45031480	31.50 (800.1)	23.60 (599.4)	82.70 (2100.6)
FTE60661480	63.00 (1600.2)	23.60 (599.4)	82.70 (2100.6)
FTE687112480	63.00 (1600.2)	23.60 (599.4)	82.70 (2100.6)
FTE75061480	63.00 (1600.2)	23.60 (599.4)	82.70 (2100.6)
FTE825112480	63.00 (1600.2)	23.60 (599.4)	82.70 (2100.6)
FTE90061480	63.00 (1600.2)	23.60 (599.4)	82.70 (2100.6)
FTE112591480	94.50 (2400.3)	23.60 (599.4)	82.70 (2100.6)
FTE135091480	94.50 (2400.3)	23.60 (599.4)	82.70 (2100.6)
FTE1500121480	126.00 (3200.4)	23.60 (599.4)	82.70 (2100.6)
FTE1800121480	126.00 (3200.4)	23.60 (599.4)	82.70 (2100.6)

Compensate Rapid Loads Within One Cycle (Typically 5–20 ms)—4.5% Inductors— Tuned to 282 Hz (4.7th Harmonic)

Catalog Number	Width	Depth	Height
FTE15652480T	31.50 (800.1)	23.60 (599.4)	82.70 (2100.6)
FTE18752480T	31.50 (800.1)	23.60 (599.4)	82.70 (2100.6)
FTE21974480T	31.50 (800.1)	23.60 (599.4)	82.70 (2100.6)
FTE25052480T	31.50 (800.1)	23.60 (599.4)	82.70 (2100.6)
FTE26274480T	31.50 (800.1)	23.60 (599.4)	82.70 (2100.6)
FTE31252480T	31.50 (800.1)	23.60 (599.4)	82.70 (2100.6)
FTE37552480T	31.50 (800.1)	23.60 (599.4)	82.07 (2100.6)
FTE43774480T	31.50 (800.1)	23.60 (599.4)	82.70 (2100.6)
FTE45031480T	31.50 (800.1)	23.60 (599.4)	82.70 (2100.6)
FTE60661480T	63.00 (1600.2)	23.60 (599.4)	82.70 (2100.6)
FTE687112480T	63.00 (1600.2)	23.60 (599.4)	82.70 (2100.6)
FTE75061480T	63.00 (1600.2)	23.60 (599.4)	82.70 (2100.6)
FTE825112480T	63.00 (1600.2)	23.60 (599.4)	82.70 (2100.6)
FTE90061480T	63.00 (1600.2)	23.60 (599.4)	82.70 (2100.6)
FTE112591480T	94.50 (2400.3)	23.60 (599.4)	82.70 (2100.6)
FTE135091480T	94.50 (2400.3)	23.60 (599.4)	82.70 (2100.6)
FTE1500121480T	126.00 (3200.4)	23.60 (599.4)	82.70 (2100.6)
FTE1800121480T	126.00 (3200.4)	23.60 (599.4)	82.70 (2100.6)

Transient-Free Reactive Power Compensation Systems— Fast Transient-Free Switching Systems—480 Vac

Compensate Any Load Within 3–4 Seconds—Standard 6% Inductors—Detuned to 245 Hz (4.08th Harmonic)

Catalog Number	Width	Depth	Height
FTA15652480	31.50 (800.1)	23.60 (599.4)	82.70 (2100.6)
FTA18752480	31.50 (800.1)	23.60 (599.4)	82.70 (2100.6)
FTA21974480	31.50 (800.1)	23.60 (599.4)	82.70 (2100.6)
FTA25052480	31.50 (800.1)	23.60 (599.4)	82.70 (2100.6)
FTA26274480	31.50 (800.1)	23.60 (599.4)	82.70 (2100.6)
FTA31252480	31.50 (800.1)	23.60 (599.4)	82.70 (2100.6)
FTA37552480	31.50 (800.1)	23.60 (599.4)	82.70 (2100.6)
FTA43774480	31.50 (800.1)	23.60 (599.4)	82.70 (2100.6)
FTA45031480	31.50 (800.1)	23.60 (599.4)	82.70 (2100.6)
FTA60661480	63.00 (1600.2)	23.60 (599.4)	82.70 (2100.6)
FTA687112480	63.00 (1600.2)	23.60 (599.4)	82.70 (2100.6)
FTA75061480	63.00 (1600.2)	23.60 (599.4)	82.70 (2100.6)
FTA825112480	63.00 (1600.2)	23.60 (599.4)	82.70 (2100.6)
FTA90061480	63.00 (1600.2)	23.60 (599.4)	82.70 (2100.6)
FTA112591480	94.50 (2400.3)	23.60 (599.4)	82.70 (2100.6)
FTA135091480	94.50 (2400.3)	23.60 (599.4)	82.70 (2100.6)
FTA1500121480	126.00 (3200.4)	23.60 (599.4)	82.70 (2100.6)
FTA1800121480	126.00 (3200.4)	23.60 (599.4)	82.70 (2100.6)

Compensate Any Load Within 3–4 Seconds—4.5% Inductors—Tuned to 282 Hz (4.7th Harmonic)

Catalog Number	Width	Depth	Height
FTA15652480T	31.50 (800.1)	23.60 (599.4)	82.70 (2100.6)
FTA18752480T	31.50 (800.1)	23.60 (599.4)	82.70 (2100.6)
FTA21974480T	31.50 (800.1)	23.60 (599.4)	82.70 (2100.6)
FTA25052480T	31.50 (800.1)	23.60 (599.4)	82.70 (2100.6)
FTA26274480T	31.50 (800.1)	23.60 (599.4)	82.70 (2100.6)
FTA31252480T	31.50 (800.1)	23.60 (599.4)	82.70 (2100.6)
FTA37552480T	31.50 (800.1)	23.60 (599.4)	82.70 (2100.6)
FTA43774480T	31.50 (800.1)	23.60 (599.4)	82.70 (2100.6)
FTA45031480T	31.50 (800.1)	23.60 (599.4)	82.70 (2100.6)
FTA60661480T	63.00 (1600.2)	23.60 (599.4)	82.07 (2100.6)
FTA687112480T	63.00 (1600.2)	23.60 (599.4)	82.70 (2100.6)
FTA75061480T	63.00 (1600.2)	23.60 (599.4)	82.70 (2100.6)
FTA825112480T	63.00 (1600.2)	23.60 (599.4)	82.70 (2100.6)
FTA90061480T	63.00 (1600.2)	23.60 (599.4)	82.70 (2100.6)
FTA112591480T	94.50 (2400.3)	23.60 (599.4)	82.70 (2100.6)
FTA135091480T	94.50 (2400.3)	23.60 (599.4)	82.70 (2100.6)
FTA1500121480T	126.00 (3200.4)	23.60 (599.4)	82.70 (2100.6)
FTA1800121480T	126.00 (3200.4)	23.60 (599.4)	82.70 (2100.6)

10

Harmonic Correction Units—NEMA 1 Enclosure



Contents

<i>Description</i>	<i>Page</i>
Product Overview	34
UNIPUMP	37
UNIPAK	40
AUTOVAR 300 Automatic Power Factor Correction Capacitor Systems	51
AUTOVAR 600 Automatic Power Factor Correction Capacitor Systems	54
AUTOVAR Filter—LV Automatic Harmonic Filter	59
Transient-Free Static Switching Power Factor Correction Units	63
Active-Harmonic Filter-Harmonic Correction Unit— NEMA 1 Enclosure	
Technical Data and Specifications	68
Wiring Diagrams	68
Dimensions	70

Active-Harmonic Filter-Harmonic Correction Unit—NEMA 1 Enclosure

Product Description

Active Harmonic Filters (Harmonic Correction Units—HCUEs) provide dynamic harmonic correction by actively injecting equal and opposite currents into the customer’s electrical distribution system that cancel the entire spectrum of harmonic currents at the point of connection.

Application Description

Typical applications include locations with large amounts of nonlinear loads including 6- and 12-pulse PWM AC variable frequency drives, DC drives, as well as other switch-mode power supply equipment. This equipment can be found in water and wastewater treatment facilities, industrial manufacturing and warehousing plants, military bases, and commercial (HVAC) locations.

Features, Benefits and Functions

Unlike passive filters, by providing dynamic correction, HCUEs can provide effective harmonic correction for varying load conditions and harmonic spectrums up to their rated capacity. HCUEs also have the secondary benefit of providing power factor correction with any excess capacity after correcting all harmonic conditions.

- Fast action
- NEMA 1 and NEMA 12 enclosures available:
 - Wallmount (50 and 100 ampere designs)
 - Floor-standing (300 ampere design)
- Touchscreen HMI
- Modbus and Ethernet connectivity

Note: Requires at least 3% series input line reactor or equivalent 6% DC bus choke in each AC drive for optimum performance.

Advantages

- Can be sized to guarantee specific levels of harmonic correction, such as meeting IEEE 519 recommended levels
- Cannot be overloaded
- Can be expanded without affecting performance
- Broad spectrum of cancellation (2nd to 50th harmonic)
- Power factor improvement
- Easier and less expensive installation
- Comprehensive control

Standards and Certifications

- UL/CSA approved



10.4

SPD, Power Conditioning, PF Capacitors and Harmonic Filters

Power Factor Correction Capacitors

Technical Data and Specifications

- 20 kHz switching carrier frequency
- 208–480V $\pm 10\%$, 600V and 690V with autotransformer
- 50/60 Hz ± 3 Hz frequency
- Ambient temperature 0°C to +40°C enclosed
- Seismic Zone 4
- Output capacity—self limited to 100% current rated
- Corrective capability— $<5\%$ TDD and near unity displacement power factor

Harmonic Control Unit Ratings—NEMA 1 Enclosed

Model	Voltage	Frequency	Total Current Amperes (rms)	Watt Losses (kw)	Enclosure Type	Disconnect
HCUE050D5N1	208–480	50/60 Hz	50	1.8	Wallmount/NEMA 1	—
HCUE100D5N1	208–480	50/60 Hz	100	3.0	Wallmount/NEMA 1	—
HCUE300D5N1	208–480	50/60 Hz	300	8.0	Free-standing/NEMA 1	X
HCUE050D6N1	600	50/60 Hz	39	1.8	Free-standing/NEMA 1	—
HCUE050D7N1	690	50/60 Hz	33	1.8	Free-standing/NEMA 1	—
HCUE100D6N1	600	50/60 Hz	78	3.0	Free-standing/NEMA 1	—
HCUE100D7N1	690	50/60 Hz	65	3.0	Free-standing/NEMA 1	—
HCUE300D6N1	600	50/60 Hz	235	8.0	Free-standing/NEMA 1	—
HCUE300D7N1	690	50/60 Hz	200	8.0	Free-standing/NEMA 1	—

Current Transformer Ratings ^①

Model	AC Line Current Rating	Type
HCUCT1000SC	1000	Split
HCUCT3000SC	3000	Split
HCUCT5000SC	5000	Split

Wiring Diagrams

Installation Diagram

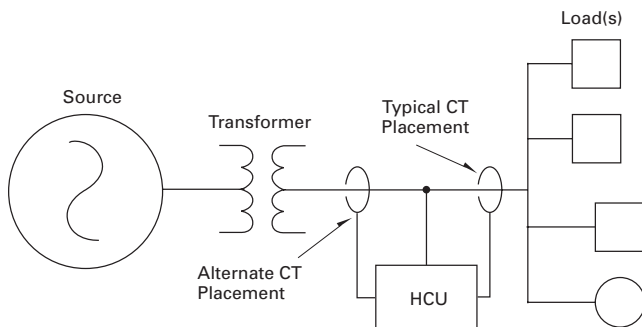

Note

- ^① Current transformers are rated for 400 Hz. Two current transformers are required for three-phase loads. Three current transformers are required when single-phase loads are present. Rating based on service entrance ampacity and optional parallel operation. For other ratios, please consult factory. Startup and commissioning by factory trained personnel is required for proper operation and warranty of this system.

Source CT Location

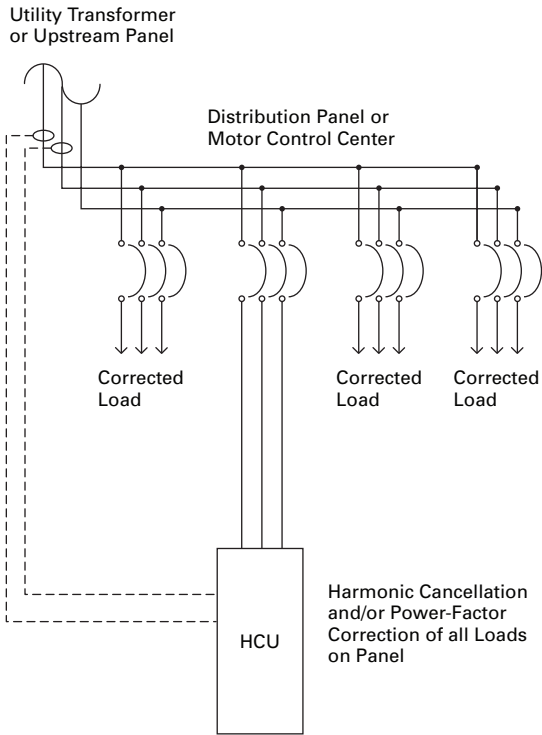

Source or Load CT Location

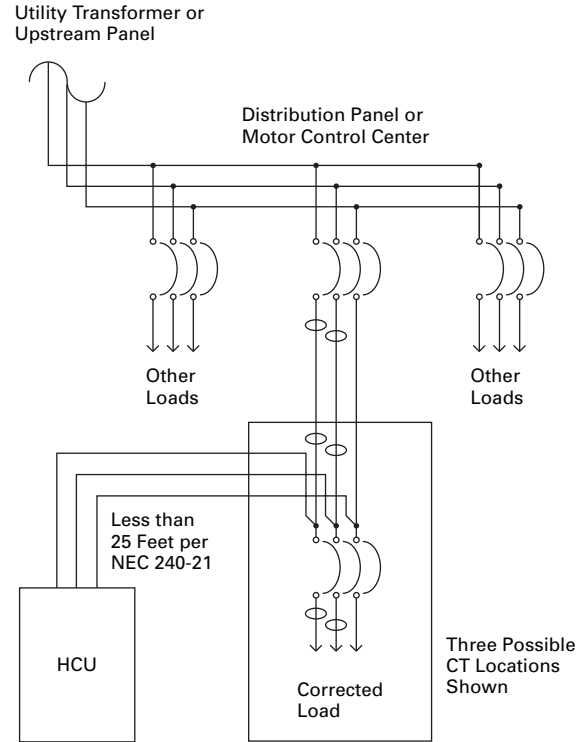

Source or Load CT Location

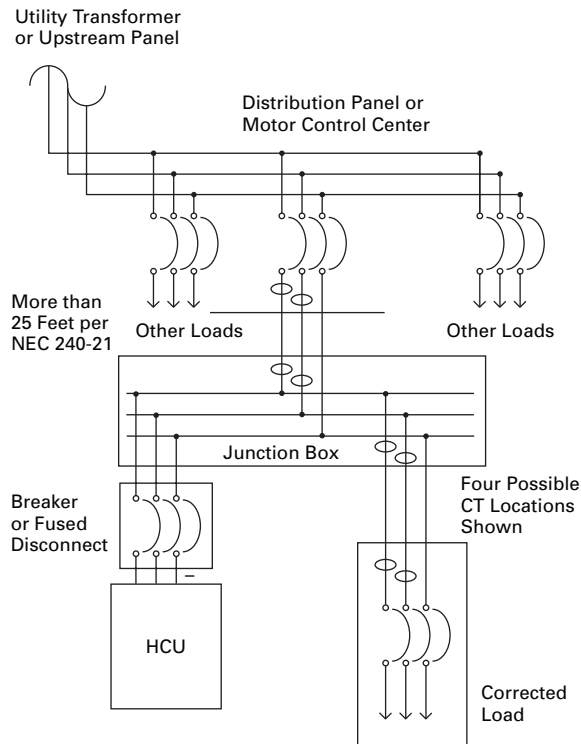

Load CT Location

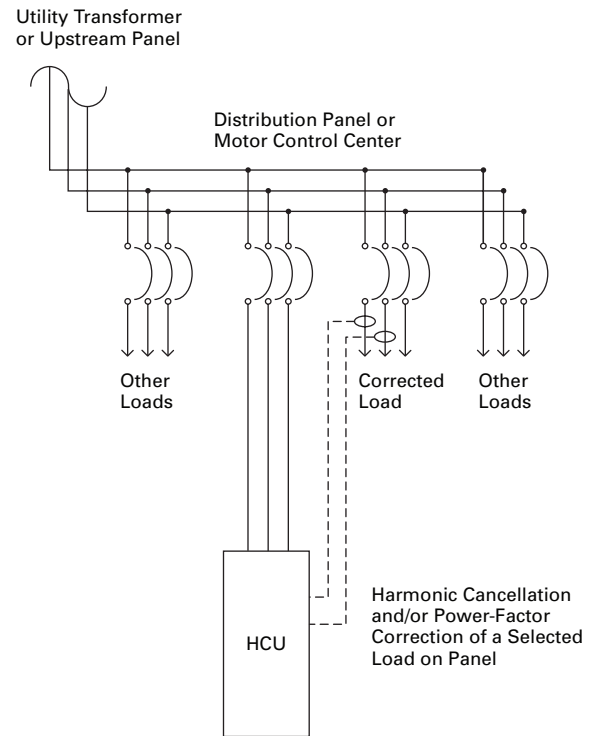

10.4

SPD, Power Conditioning, PF Capacitors and Harmonic Filters

Power Factor Correction Capacitors

Dimensions

Approximate Dimensions in Inches (mm)

Harmonic Control—NEMA 1 Enclosed

Model	Exterior			Unit Weight in Lbs (kg)
	Height	Weight	Depth	
HCUE050D5N1	51.80 (1315.7)	20.70 (525.8)	18.50 (469.9)	250 (113.5)
HCUE100D5N1	68.70 (1745.0)	20.70 (525.8)	18.50 (469.9)	350 (158.9)
HCUE300D5N1	74.90 (1902.5)	32.20 (817.9)	19.50 (495.3)	775 (351.9)
HCUE050D6N1	①	①	①	①
HCUE050D7N1	①	①	①	①
HCUE100D6N1	①	①	①	①
HCUE100D7N1	①	①	①	①
HCUE300D6N1	①	①	①	①
HCUE300D7N1	①	①	①	①

Current Transformer

Model	Internal Diameter
HCUCT1000SC	4.65 (118.1)
HCUCT3000SC	6.50 (165.1)
HCUCT5000SC	7.50 (190.5)

Auxiliary Current Transformers ②

Model	Ratio	Type
HCUCT7RL6011	600/1	Solid round core
HCUCT7RL1021	1000/1	Solid round core

Notes

- ① Consult factory.
- ② Required for parallel operation of HCU and for units with transformers. Use the same number of auxiliary CTs as main sensing CTs.

Approximate Dimensions in Inches (mm)

Drawings—NEMA 1 Enclosure

HCUE050 Layout Dimensions

The HCUE050 series offers 50 amperes of corrective current in a convenient package. The enclosed model comes standard with a digital interface panel for control diagnostics and programming. Input fuses are included. The enclosed unit includes a removable panel for bottom conduit entry.

HCUE050—50 Amperes, 208–480V

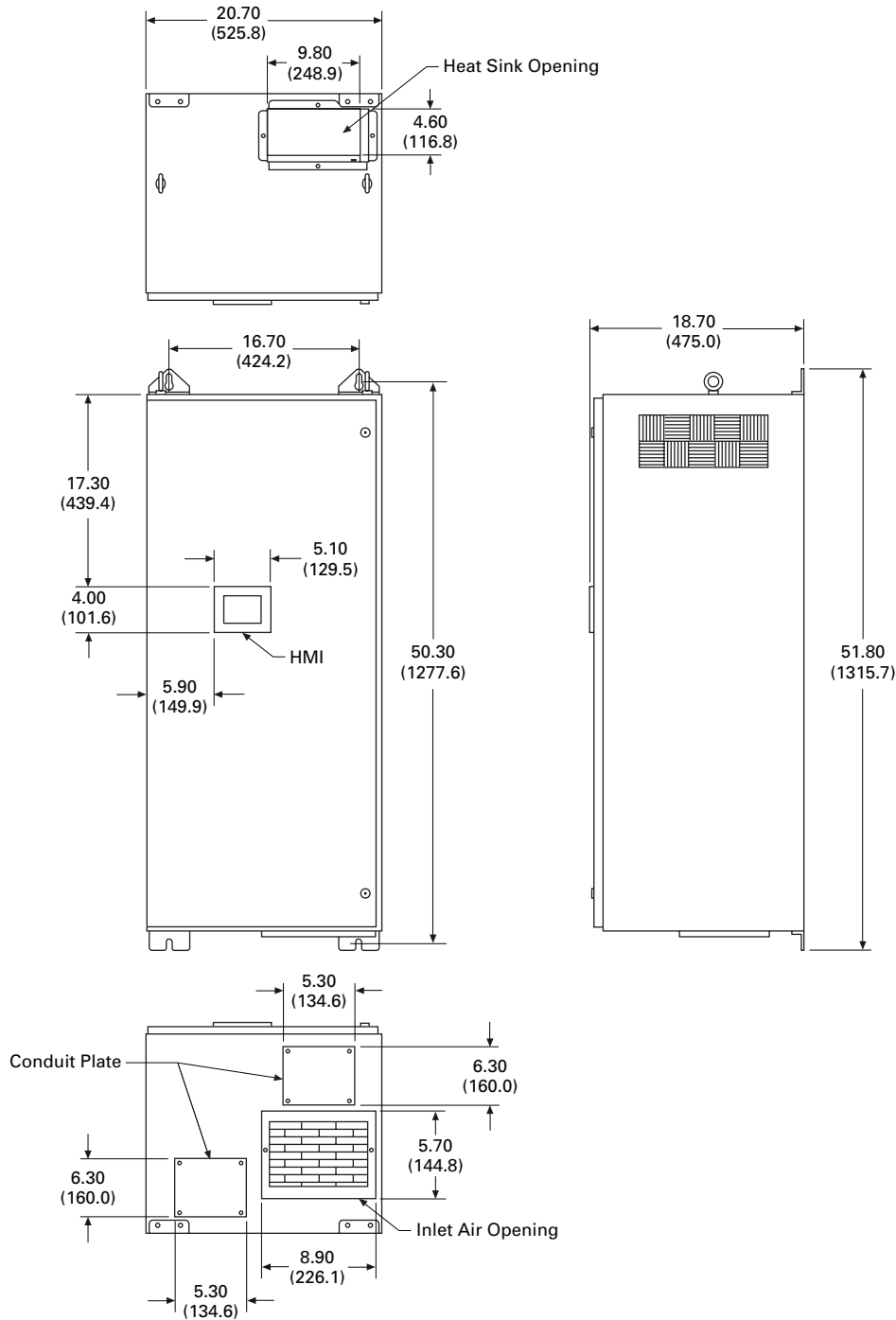

10.4

SPD, Power Conditioning, PF Capacitors and Harmonic Filters

Power Factor Correction Capacitors

Approximate Dimensions in Inches (mm)

HCUE100 Layout Dimensions

The HCUE100 series offers 100 amperes of corrective current in a wallmounted NEMA 1 enclosure. The enclosed model comes standard with a digital interface module for control, diagnostics and programming. Input fuses are included. The enclosed unit includes a removable panel for bottom conduit entry.

HCUE100—100 Amperes 208–480V

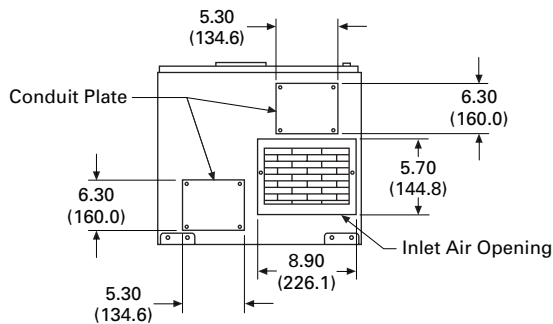
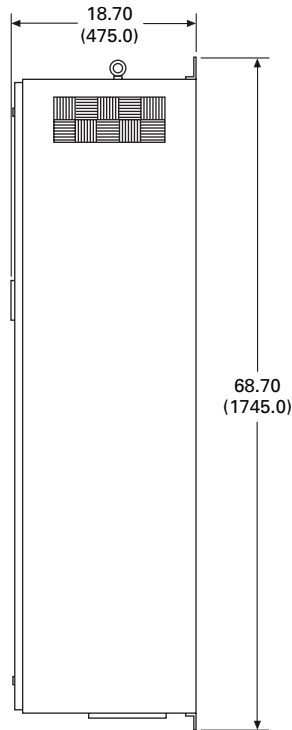
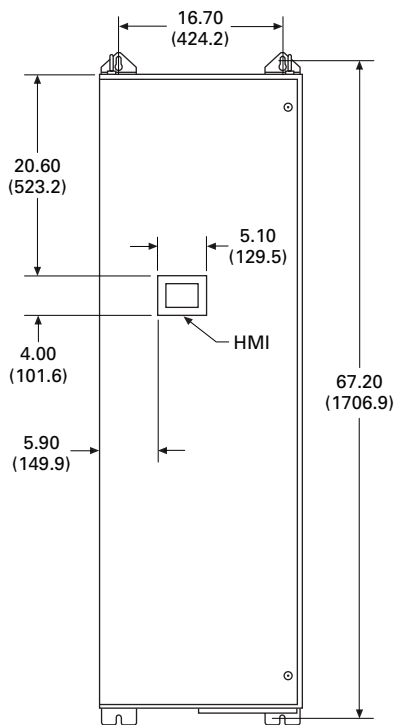
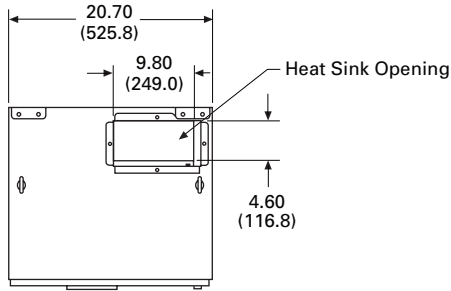

Approximate Dimensions in Inches (mm)

HCUE300 Layout Dimensions

The HCUE300 series offers 300 amperes of corrective current for large capacity applications. It is available in a floor-standing NEMA 1 enclosure (including a door-interlocking disconnect). The enclosed model comes standard with digital interface module for control, diagnostics and programming. Input fuses are included. The enclosed unit includes a removable panel for top conduit entry.

HCUE300—300 Amperes 208–480V

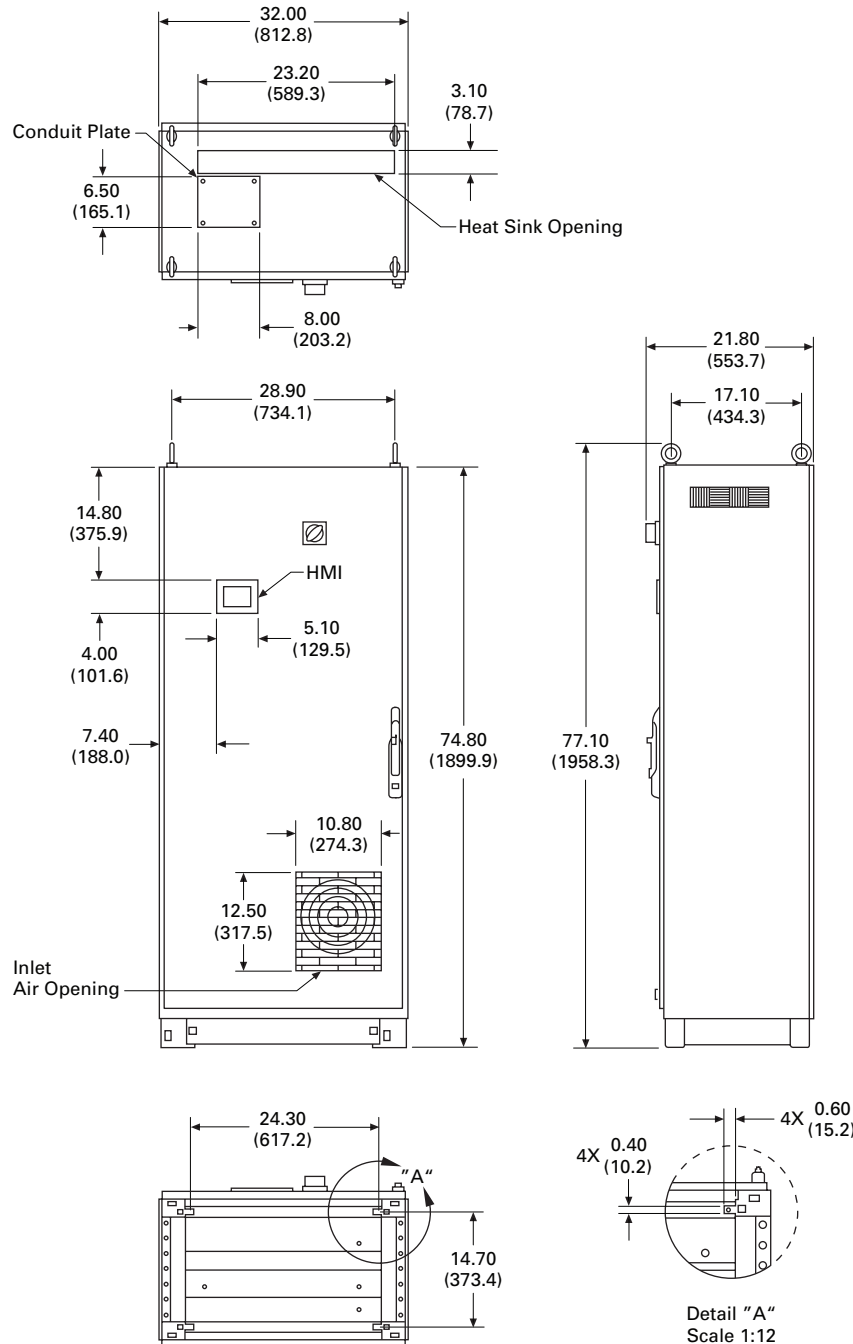

10.4

SPD, Power Conditioning, PF Capacitors and Harmonic Filters

Power Factor Correction Capacitors